

ULINE H-10126 DELUXE DESKTOP ORGANIZER

1-800-295-5510
uline.com

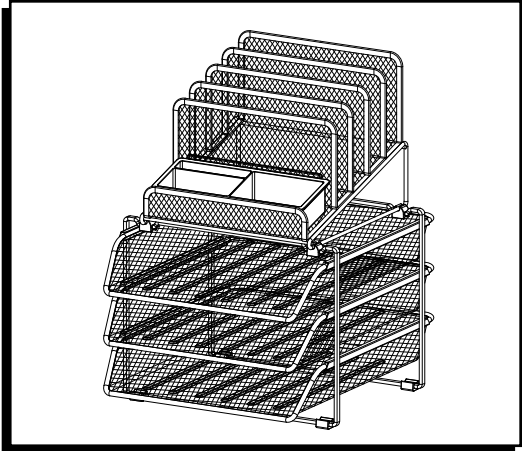

PARTS

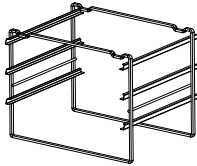

Main Frame x 1

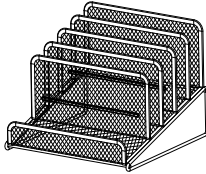

File Holder x 1



Mesh Tray x 3

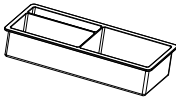

Divided Tray x 1



Snap Connector x 4



Protective Foot x 4

ASSEMBLY

1. Attach protective feet to bottom of main frame. (See Figure 1)
2. Attach snap connectors to top of main frame. (See Figure 1)

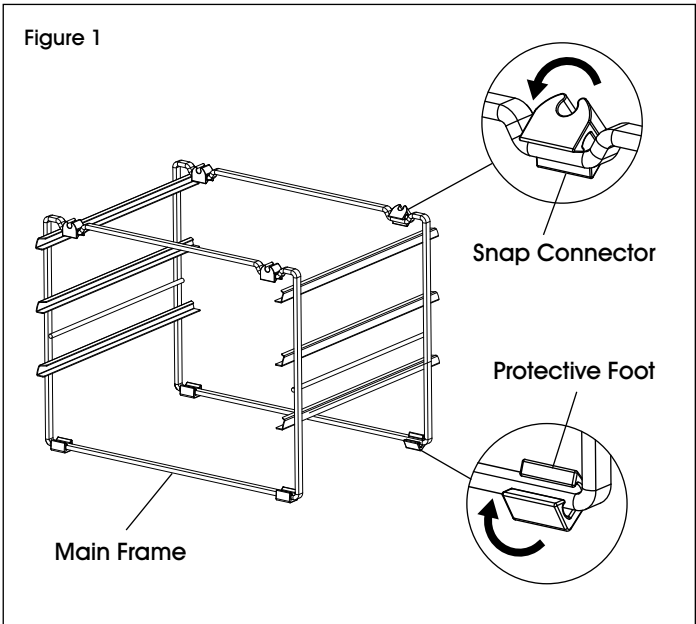

ASSEMBLY CONTINUED

3. Place divided tray inside file holder. (See Figure 2)
4. Connect file holder to main frame by pressing file holder firmly into slots of snap connectors. (See Figures 2-3)

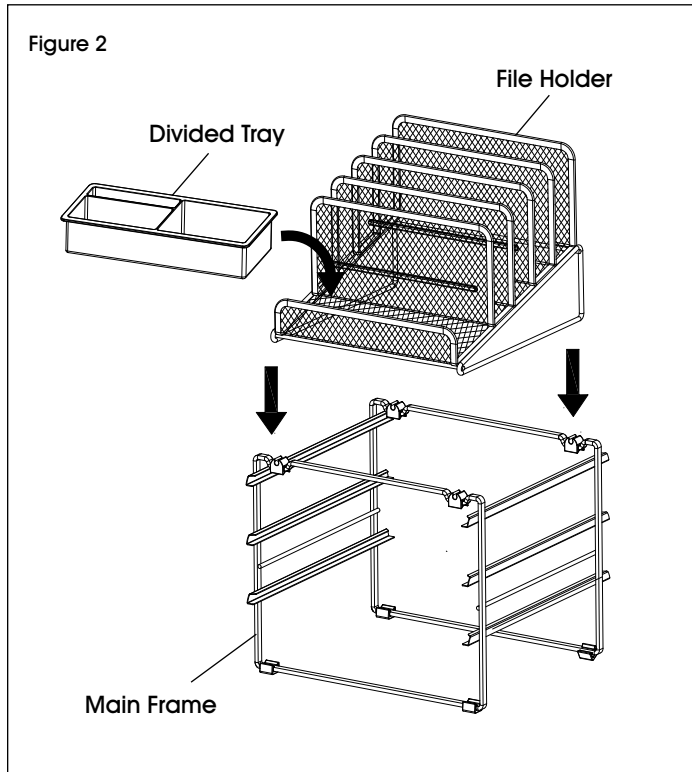

5. Slide mesh trays into main frame. (See Figure 3)

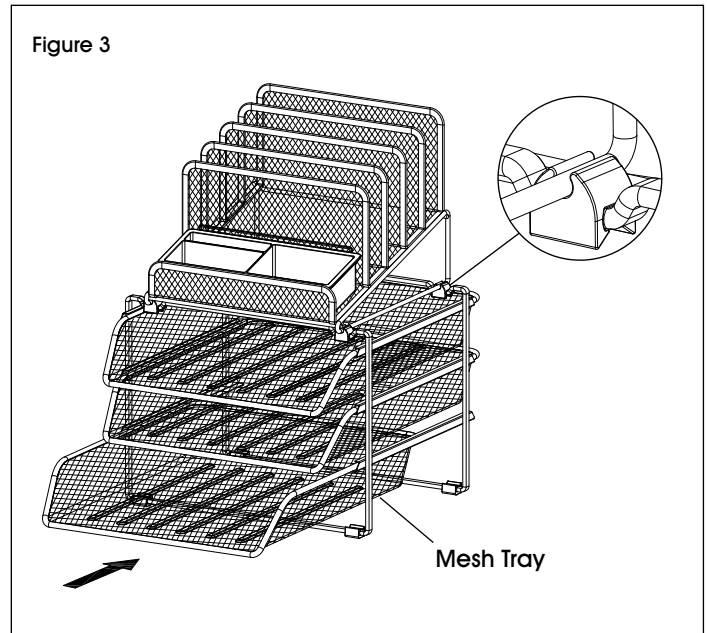

ULINE H-10126
ORGANIZADOR
DE ESCRITORIO
DE ALTA CALIDAD

800-295-5510
uline.mx

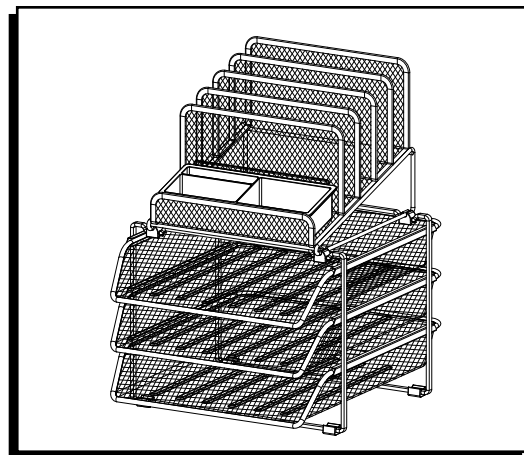

PARTES

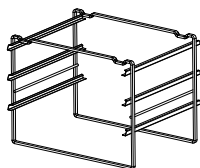

1 Armazón Principal

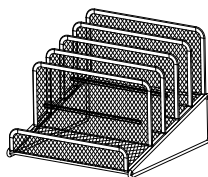

1 Portaarchivo



3 Bandejas de Malla

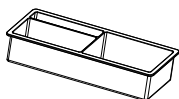

1 Bandeja Dividida



4 Conectores de Presión



4 Patas Protectoras

ENSAMBLE

1. Fije las patas protectoras a la parte inferior del armazón principal. (Vea Diagrama 1)
2. Fije los conectores de presión a la parte superior del armazón principal. (Vea Diagrama 1)

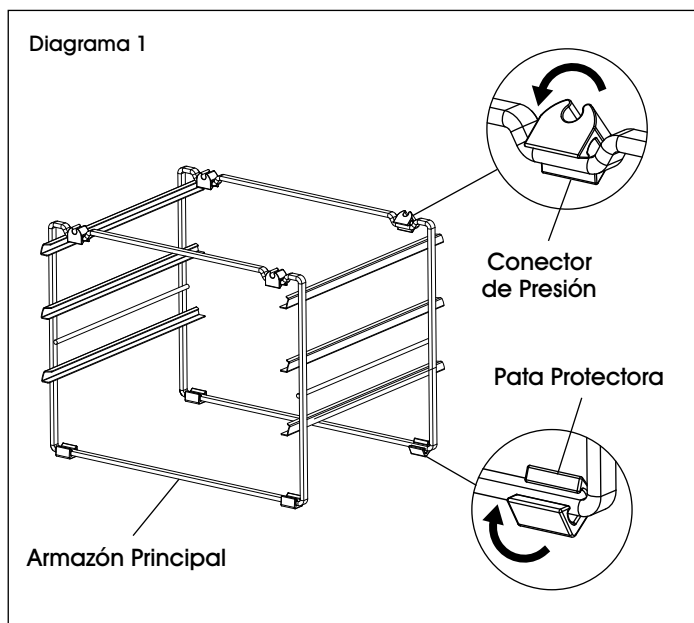

CONTINUACIÓN DEL ENSAMBLE

3. Coloque la repisa dividida dentro del portaarchivo. (Vea Diagrama 2)
4. Conecte el portaarchivo presionándolo firmemente al armazón principal en las ranuras de los conectores de presión. (Vea Diagramas 2-3)
5. Deslice las bandejas de malla en el armazón principal. (Vea Diagrama 3)

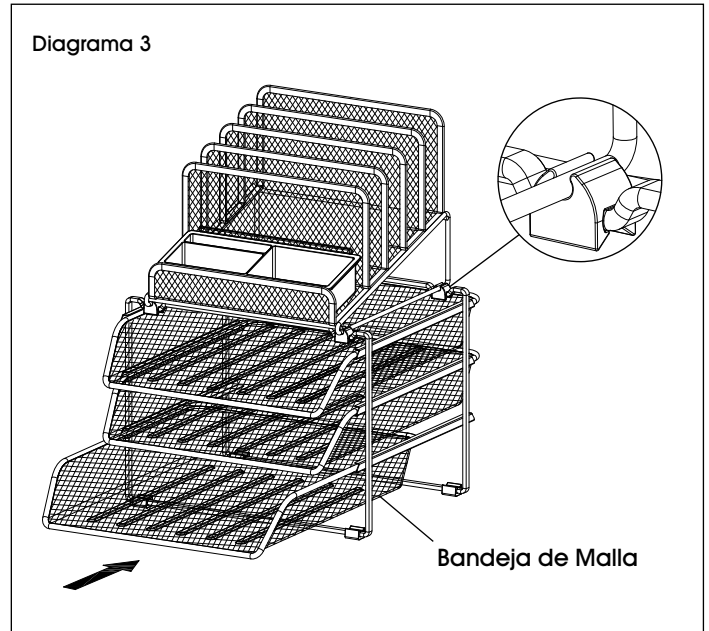
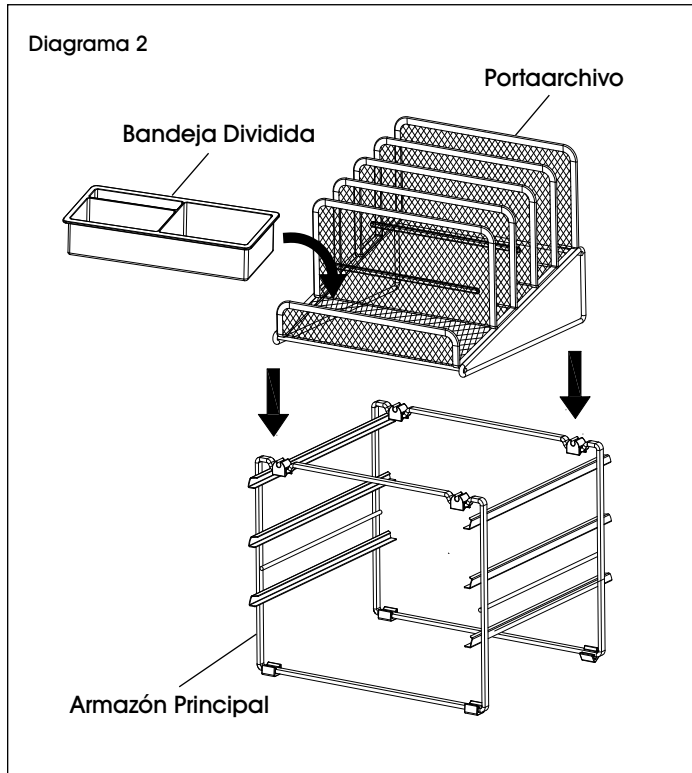

ULINE H-10126
RANGE-TOUT DE
LUXE DE BUREAU

1-800-295-5510
uline.ca

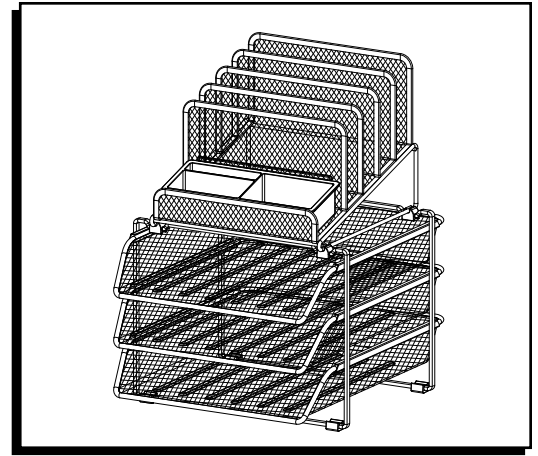

PIÈCES

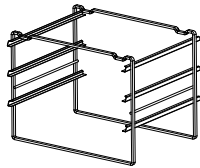

Cadre principal x 1

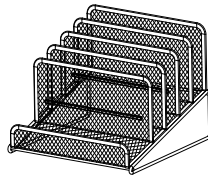

Range-documents x 1



Bac en treillis métallique x 3

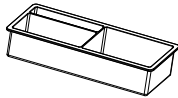

Plateau avec compartiments x 1



Raccord encliquetable x 4



Patte de protection x 4

MONTAGE

1. Fixez les pattes de protection sous le cadre principal. (Voir Figure 1)
2. Fixez les raccords encliquetables sur le cadre principal. (Voir Figure 1)

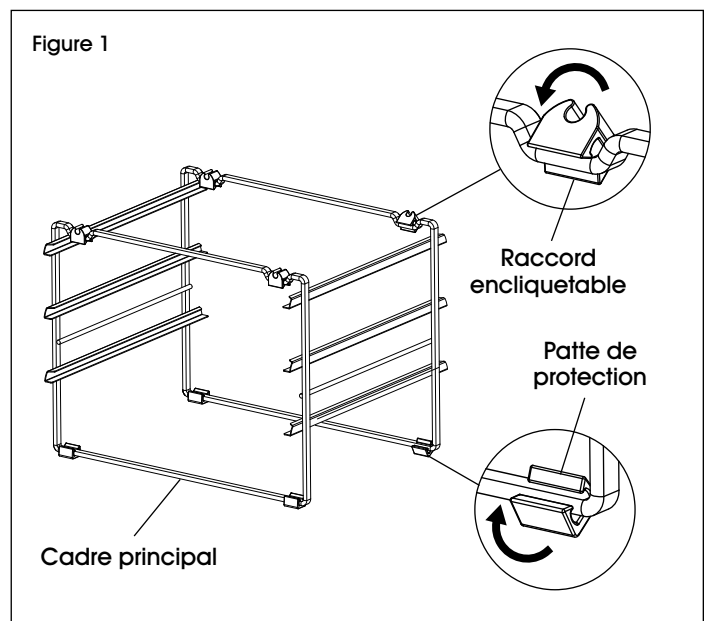

MONTAGE SUITE

3. Placez le plateau avec compartiments dans le range-documents. (Voir Figure 2)
4. Attachez le range-documents au cadre principal en appuyant fermement dessus pour qu'il s'engage dans les fentes des raccords encliquetables. (Voir Figures 2 et 3)

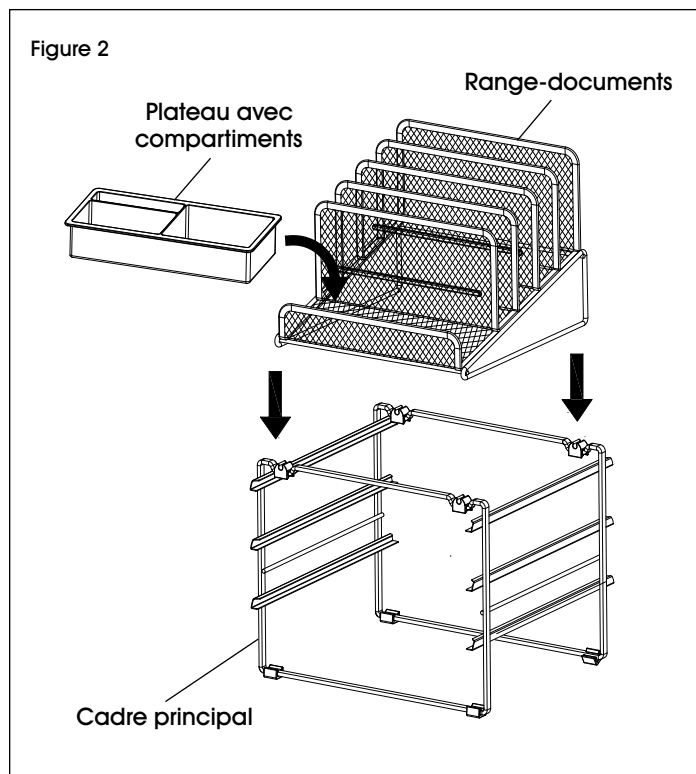

5. Glissez les bacs en treillis métallique dans le cadre principal. (Voir Figure 3)

