

# ULINE H-10212, H-10213 WORKBENCH PEDESTAL

1-800-295-5510  
uline.com

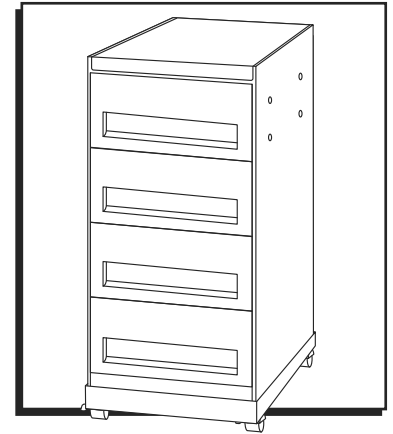

## TOOL NEEDED



1/2" Wrench

 Two Person Assembly  
Recommended

## PARTS

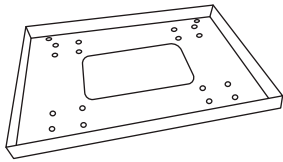

Dolly Frame x 1

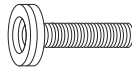

Leveling Foot x 4



Hex Nut x 16

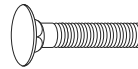

Carriage Bolt x 16



Lock Washer x 16



Flat Washer x 16

## ASSEMBLY

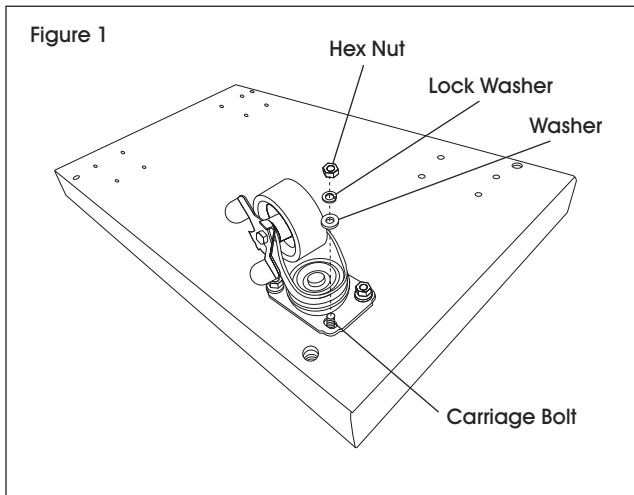

1. Attach caster to dolly frame with four carriage bolts, four flat washers, four lock washers, four hex nuts and 1/2" wrench. Repeat for remaining three casters. (See Figure 1)



**NOTE:** Bolt thread should protrude from the bottom of the frame. Bolt head will sit flush inside frame.



**NOTE:** Locking swivel casters should be positioned on the front end of frame. Rigid casters on the back side of frame.

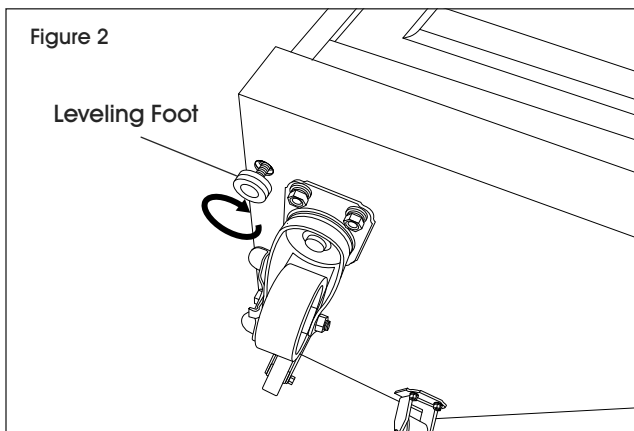

2. With a second person, place pedestal on its back. Fit dolly onto bottom of pedestal and align holes in dolly with threaded holes on pedestal. (See Figure 2)
3. Remove four leveling feet from top drawer and place one into each threaded hole. Turn clockwise to secure the dolly to the pedestal. (See Figure 2)



**IMPORTANT!** Ensure that casters are locked.

4. Return pedestal and caster assembly to upright position.

# ULINE H-10212, H-10213

## PEDESTAL PARA MESA DE TRABAJO

800-295-5510  
uline.mx

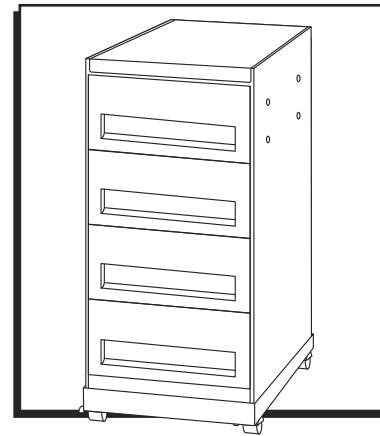

### HERRAMIENTA NECESARIA



Llave de 1/2"



Se recomienda Armar  
Entre Dos Personas

### PARTES

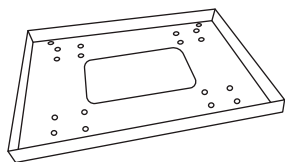

1 Armazón de la Plataforma

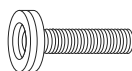

4 Patas de Nivelación



16 Tuercas Hexagonales

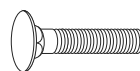

16 Pernos de Cabeza Redonda



16 Rondanas de Seguridad



16 Rondanas Planas

### ENSAMBLE

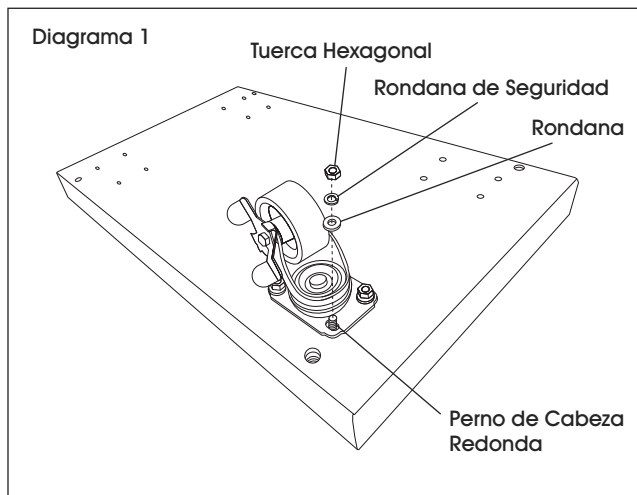

1. Fije la rueda al armazón de la plataforma con cuatro pernos de cabeza redonda, cuatro rondanas planas, cuatro rondanas de seguridad, cuatro pernos hexagonales y una llave de 1/2". Repita la operación con las tres ruedas restantes. (Vea Diagrama 1)



**NOTA:** La rosca del perno debe sobresalir de la parte inferior del armazón. La cabeza del perno quedará a ras dentro del armazón.



**NOTA:** Las ruedas giratorias con seguro se deben posicionar en el extremo frontal del armazón. Las ruedas rígidas en el lado posterior.

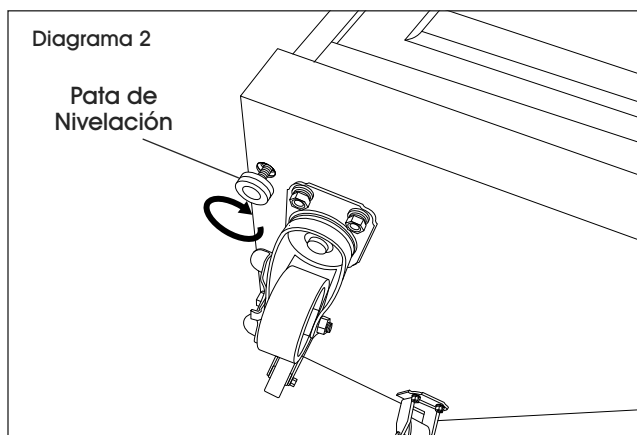

2. Con la ayuda de otra persona, coloque el pedestal sobre su parte posterior. Coloque la plataforma en la parte inferior del pedestal y alinee sus orificios con los orificios roscados del pedestal. (Vea Diagrama 2)
3. Retire las cuatro patas de nivelación del cajón superior y coloque una en cada orificio roscado. Gire en el sentido de las manecillas del reloj para asegurar la plataforma al pedestal. (Vea Diagrama 2)



**¡¡IMPORTANTE!** Asegúrese de que las ruedas estén bloqueadas.

4. Regrese el pedestal y el ensamble de las ruedas a la posición vertical.

# ULINE H-10212, H-10213

## CAISSON D'ÉTABLI

1-800-295-5510  
uline.ca

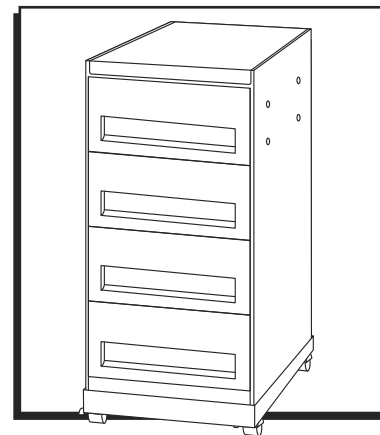

### OUTIL REQUIS



Clé de 1/2 po



Montage à deux  
personnes recommandé

### PIÈCES

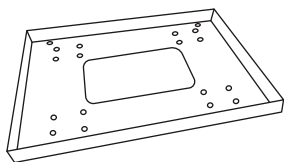

Cadre de socle  
roulant x 4

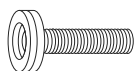

Patte de  
nivellement x 4



Écrou  
hexagonal x 16

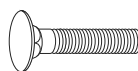

Boulon de  
carrosserie x 16



Rondelle de  
blocage x 16



Rondelle plate x 16

### MONTAGE

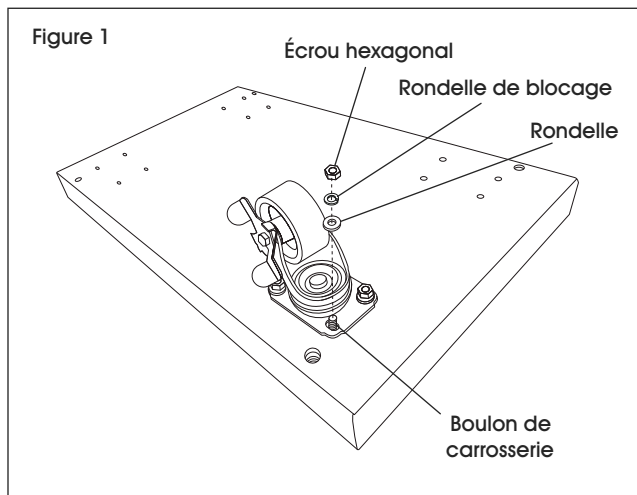

1. Fixez une roulette au cadre de socle roulant à l'aide d'une clé de 1/2 po et de quatre boulons de carrosserie, quatre rondelles plates, quatre rondelles de blocage et quatre écrous hexagonaux. Répétez l'étape pour les trois autres roulettes. (Voir Figure 1)



**REMARQUE :** La partie fileté du boulon doit dépasser par le bas du cadre. La tête du boulon sera complètement insérée dans le cadre.



**REMARQUE :** Les roulettes pivotantes blocables doivent être installées à l'avant du cadre, et les roulettes fixes à l'arrière.

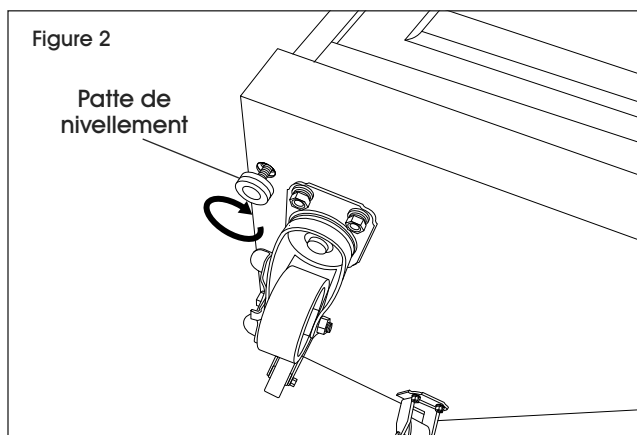

2. À deux, placez le caisson sur le dos. Installez le socle roulant au bas du caisson et alignez les trous du socle sur les trous filetés du caisson. (Voir Figure 2)
3. Retirez les quatre pattes de nivellement du tiroir supérieur et placez chacune d'elles dans les trous filetés. Tournez-les dans le sens horaire pour fixer le socle roulant au caisson. (Voir Figure 2)



**IMPORTANT!** Assurez-vous que les roulettes sont bien verrouillées.

4. Placez l'ensemble du caisson et des roulettes à l'endroit.