

# ULINE H-10267 LEATHER BUCKET CHAIR

1-800-295-5510  
uline.com

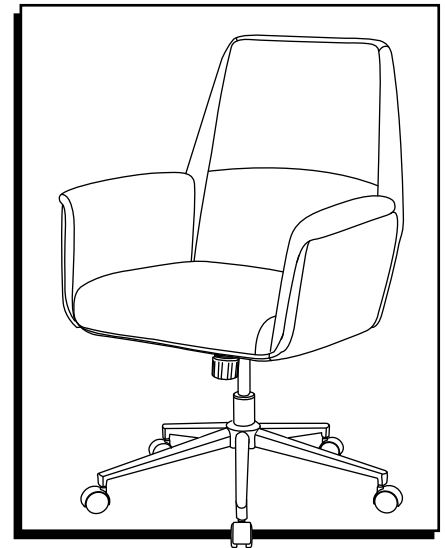

## TOOL NEEDED



Allen Wrench  
(included)

## PARTS

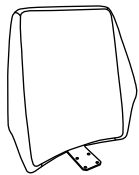

Back Cushion x 1

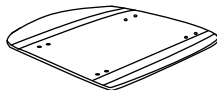

Seat Plate x 1

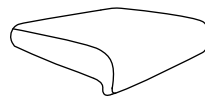

Seat Cushion x 1

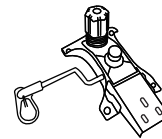

Mechanism x 1

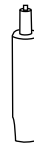

Gas Lift x 1

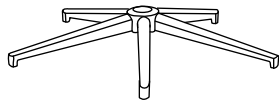

5-Star Base x 1

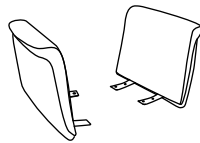

Armrest x 2



Caster x 5

### Hardware Kit



Hex Bolt x 4  
5/16 x 3/4"



Hex Bolt x 8  
1/4 x 15/16"



Bolt x 3  
5/16 x 3/4"

## ASSEMBLY

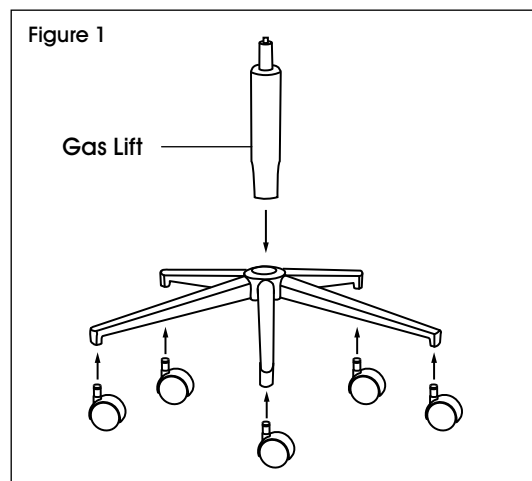

1. Turn five-star base upside down and insert casters into legs. Turn base upright. Insert gas lift into center of base. (See Figure 1)

## ASSEMBLY CONTINUED

Figure 2

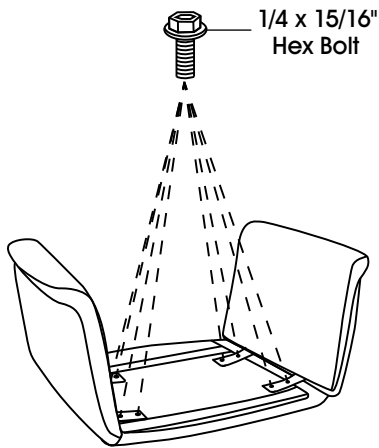

2. Remove seat cushion from the seat plate. Align holes in the armrest brackets with holes on the seat plate. Connect armrests to seat plate using eight 1/4 x 15/16" hex bolts. (See Figure 2)



**NOTE:** Use Allen wrench to tightly secure all bolts.

Figure 3

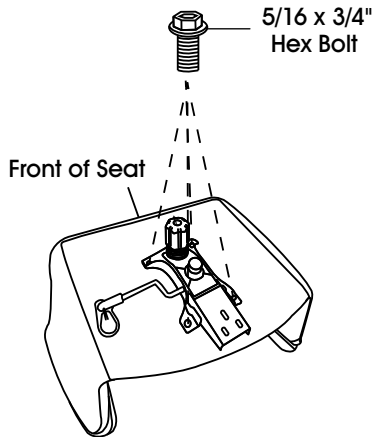

3. Align mechanism with the holes on the bottom of the seat plate. Ensure tension knob is facing the front of the seat. Use four 5/16 x 3/4" hex bolts to attach. (See Figure 3)

Figure 4

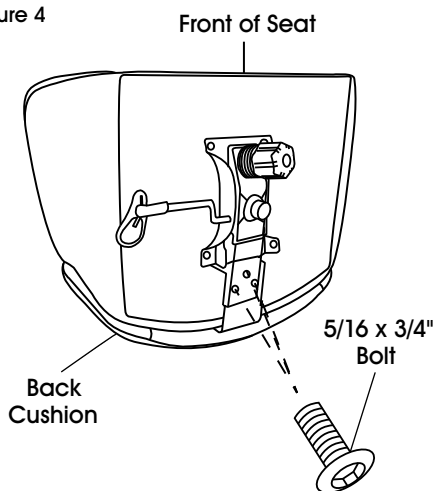

4. Align holes on the back cushion's bracket with the holes in the mechanism. Install using three 5/16 x 3/4" bolts. (See Figure 4)

## ASSEMBLY CONTINUED

Figure 5

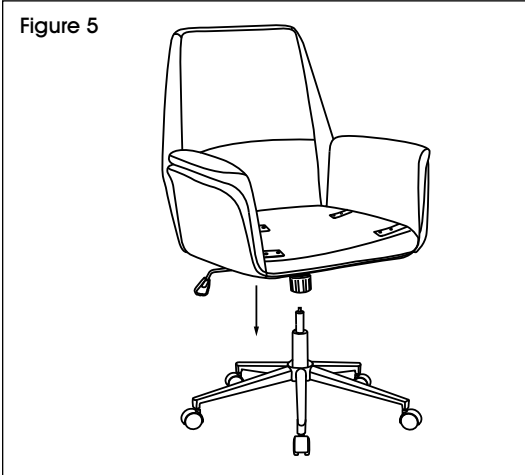

5. Slowly lower seat onto gas lift. Press down on seat plate to secure. (See Figure 5)

Figure 6

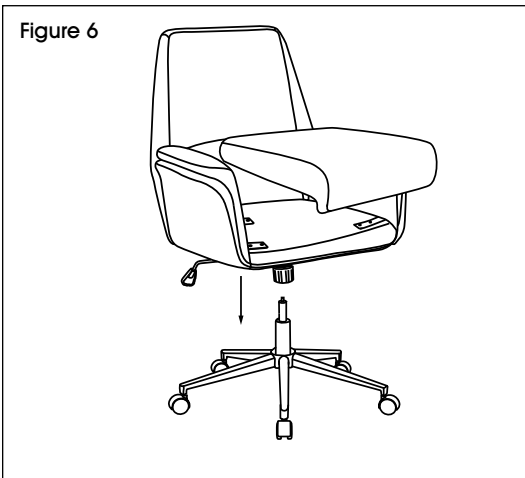

6. Place seat cushion onto seat plate and press down. (See Figure 6)

## CHAIR ADJUSTMENTS

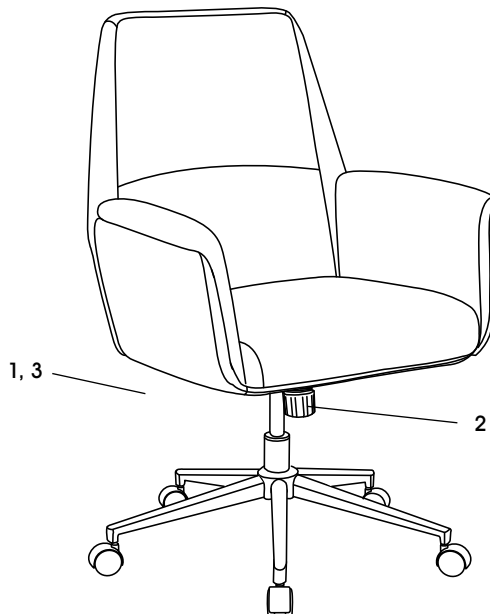

1. Seat Height – To raise seat height, push lever down with little to no weight on the seat. To lower seat height, push lever down while sitting.
2. Tilt Tension – To increase tilt tension, turn knob clockwise. To decrease tilt tension, turn knob counterclockwise.
3. Upright Tilt Lock – To lock chair in an upright position, push the lever in toward the center of the seat. To restore tilt, pull lever out. Chair has synchro-tilt; the back tilts at a two-to-one ratio to the seat angle.

**ULINE**

1-800-295-5510  
uline.com

**ULINE** H-10267

**SILLA DE PIEL  
TIPO BUTACA**

800-295-5510  
uline.mx

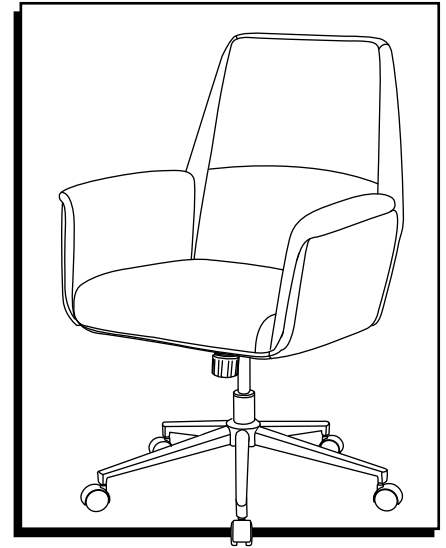

### HERRAMIENTA NECESARIA



Llave Allen  
(incluida)

### PARTES

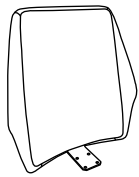

1 Respaldo

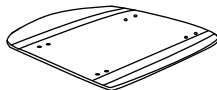

1 Placa para Asiento

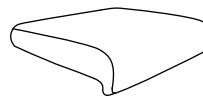

1 Asiento

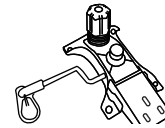

1 Mecanismo



1 Pistón de Gas

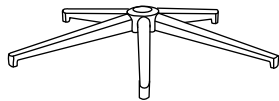

1 Base Estrella

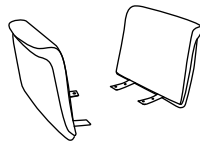

2 Descansabrazos



5 Ruedas

#### Kit de Tornillería



4 Pernos  
5/16 x 3/4"



8 Pernos  
1/4 x 15/16"



3 Pernos  
5/16 x 3/4"

### ENSAMBLE

Diagrama 1

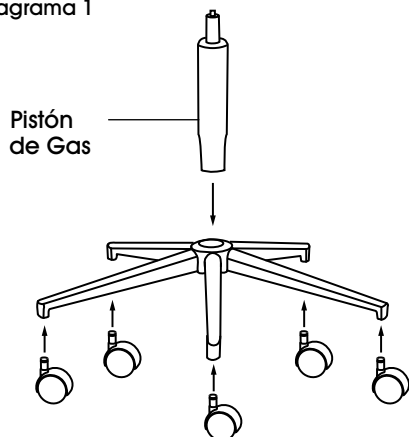

1. Voltee la base estrella e inserte las ruedas en las patas. Enderece la base. Inserte el pistón de gas en la base. (Vea Diagrama 1)

## CONTINUACIÓN DEL ENSAMBLE

Diagrama 2

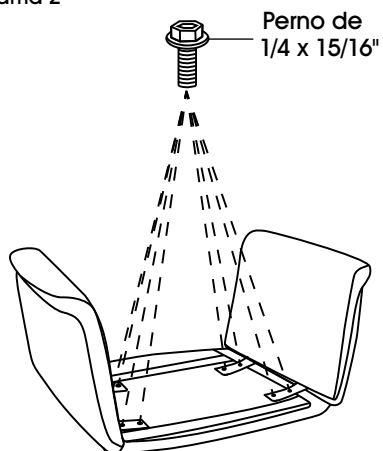

2. Retire el asiento de la placa para asiento. Alinee los orificios de los soportes para descansabrazos con los de la placa para asiento. Conecte los descansabrazos a la placa para asiento utilizando ocho pernos de 1/4 x 15/16". (Vea Diagrama 2)



**NOTA:** Utilice la llave Allen para apretar todos los pernos.

Diagrama 3

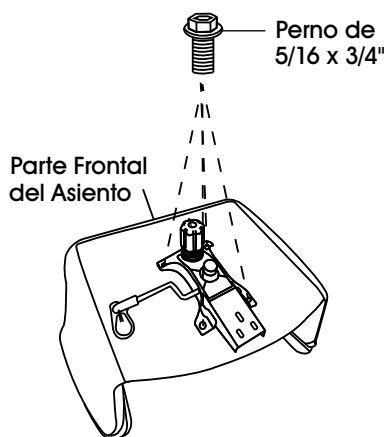

3. Alinee el mecanismo con los orificios en la parte inferior de la placa para asiento. Asegúrese de que la perilla de tensión apunte hacia la parte frontal del asiento. Use cuatro tornillos de 5/16 x 3/4" (9) para fijarla. (Vea Diagrama 3)

Diagrama 4

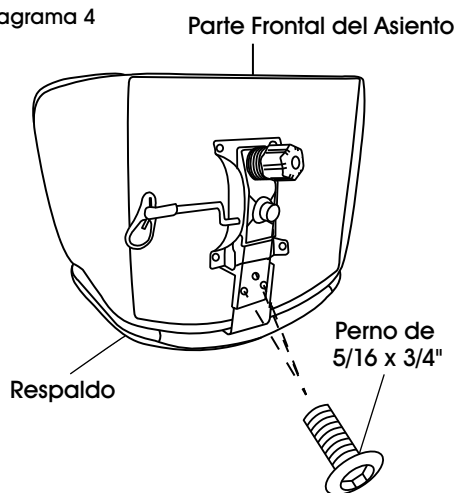

4. Alinee los orificios del soporte del respaldo con los orificios del mecanismo. Instale utilizando tres pernos de 5/16 x 3/4". (Vea Diagrama 4)

## CONTINUACIÓN DEL ENSAMBLE

Diagrama 5

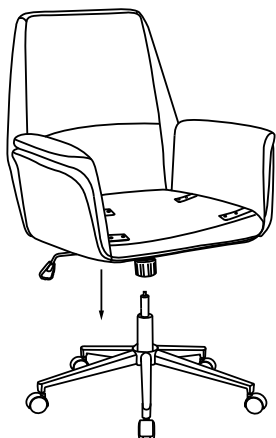

5. Baje lentamente el asiento sobre el pistón de gas. Presione la placa para asiento para asegurarla. (Vea Diagrama 5)

Diagrama 6



6. Coloque el asiento sobre la placa para asiento y presione. (Vea Diagrama 6)

## AJUSTES DE LA SILLA

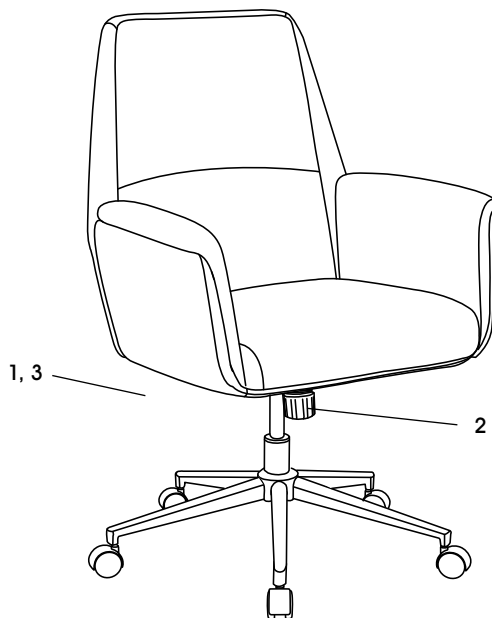

1. Altura del Asiento – Para subir la altura del asiento, empuje la palanca sin o con poco peso en el asiento. Para bajar el asiento, empuje la palanca mientras está sentado.
2. Tensión de Inclinación – Para aumentar la tensión de la inclinación, gire la perilla en el sentido de las manecillas del reloj. Para disminuir la tensión de la inclinación, gire la perilla en el sentido contrario de las manecillas del reloj.
3. Bloqueo de la Inclinación del Poste – Para bloquear la silla en una posición vertical, empuje la palanca hacia el centro del asiento. Para restaurar la inclinación, jale la palanca hacia afuera. La silla cuenta con inclinación sincronizada; el respaldo se inclina en una proporción de dos a uno con respecto al ángulo del asiento.

**ULINE**

800-295-5510  
uline.mx

# ULINE H-10267 FAUTEUIL BAQUET EN CUIR

1-800-295-5510  
uline.ca

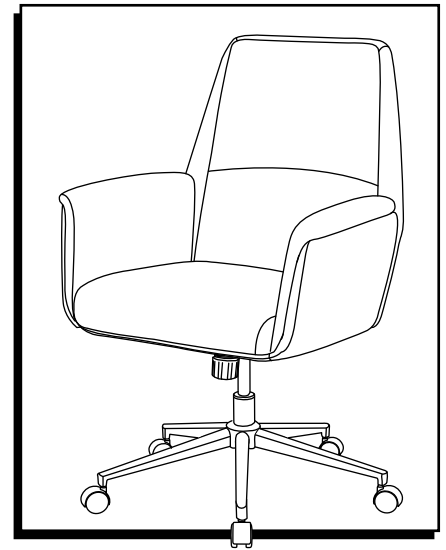

## OUTIL REQUIS

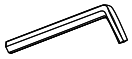

Clé Allen  
(Inclus)

## PIÈCES

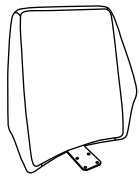

Dossier x 1

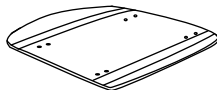

Plaque de siège x 1

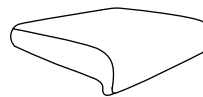

Siège x 1

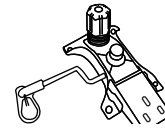

Mécanisme x 1



Vérin pneumatique x 1

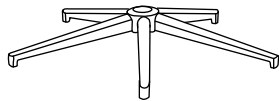

Base à 5 branches x 1

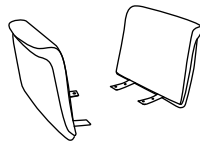

Accoudoir x 2



Roulette x 5

### Matériel de fixation



Boulon x 4  
5/16 x 3/4 po



Boulon x 8  
1/4 x 15/16 po



Boulon x 3  
5/16 x 3/4 po

## MONTAGE

Figure 1

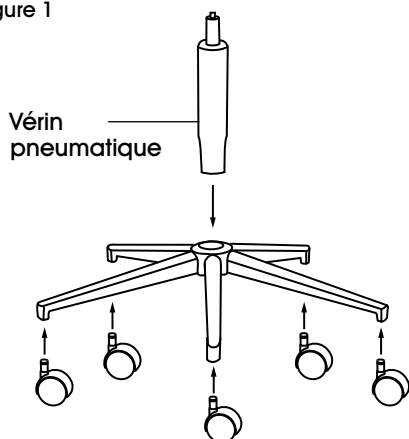

1. Tournez la base à 5 branches à l'envers et insérez les roulettes dans les pieds. Tournez la base à l'endroit. Insérez le vérin pneumatique dans le centre de la base. (Voir Figure 1)

## MONTAGE SUITE

Figure 2

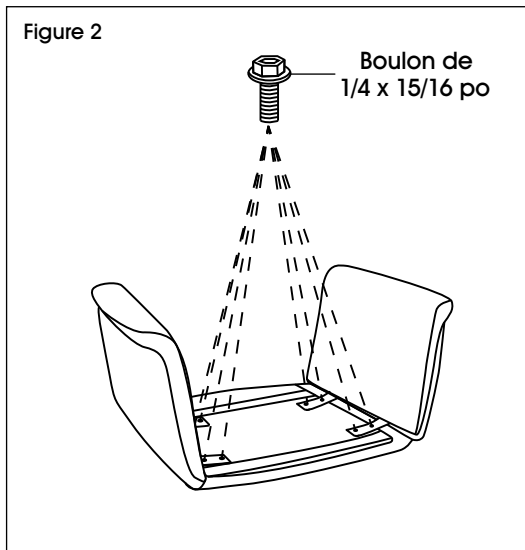

2. Retirez le siège de la plaque de siège. Alignez les trous des supports d'accoudoir sur les trous de la plaque de siège. Fixez les accoudoirs à la plaque de siège avec huit boulons de 1/4 x 15/16 po. (Voir Figure 2)



**REMARQUE :** Utilisez la clé Allen pour bien serrer tous les boulons.

Figure 3

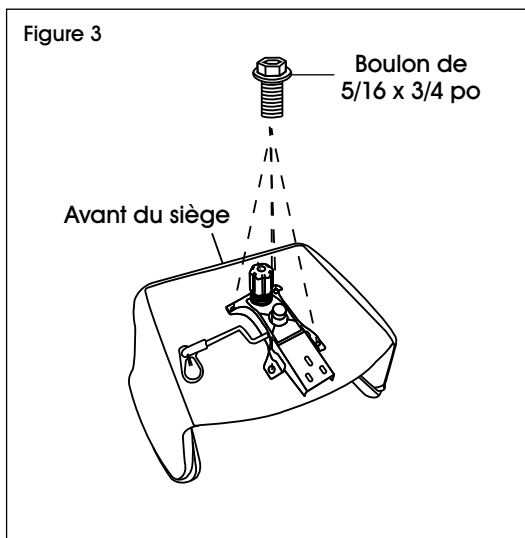

3. Alignez le mécanisme sur les trous situés sous la plaque de siège. Assurez-vous que la molette de tension est orientée vers l'avant du siège. Fixez-le avec quatre boulons de 5/16 x 3/4 po. (Voir Figure 3)

Figure 4

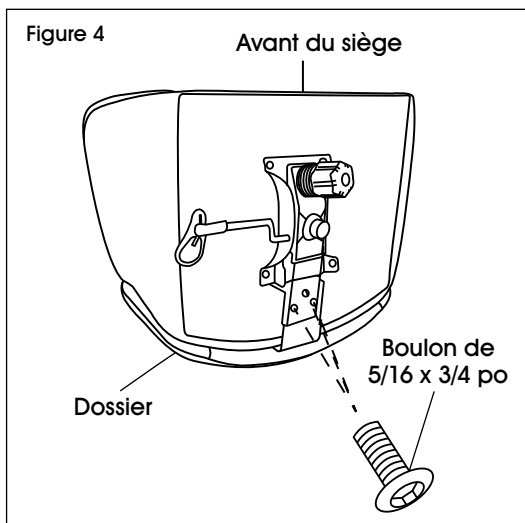

4. Alignez les trous du support de dossier sur les trous du mécanisme. Fixez-le avec trois boulons de 5/16 x 3/4 po. (Voir Figure 4)



## MONTAGE SUITE

Figure 5

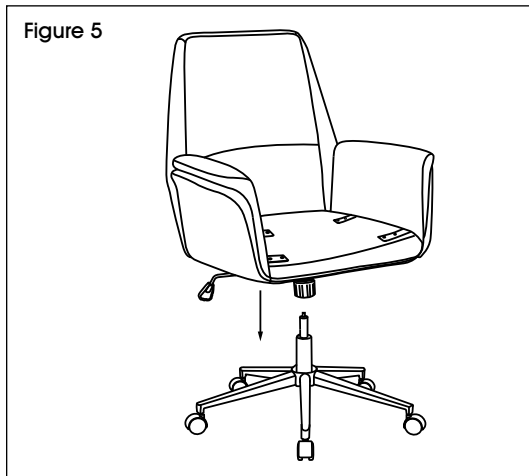

5. Positionnez attentivement l'ensemble du siège sur le vérin pneumatique. Appuyez sur la plaque de siège pour la fixer. (Voir Figure 5)

Figure 6

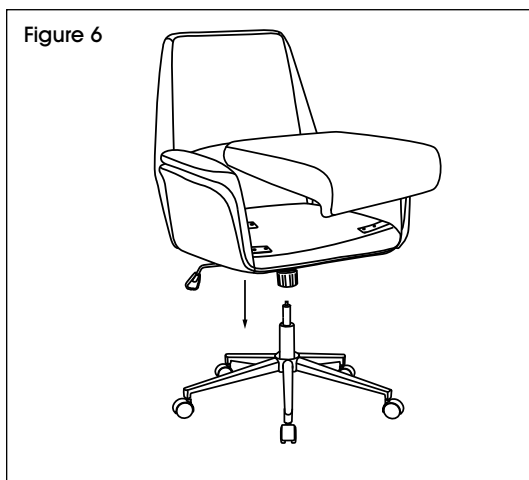

6. Placez le siège sur la plaque de siège et appuyez dessus. (Voir Figure 6)

## RÉGLAGES DU FAUTEUIL

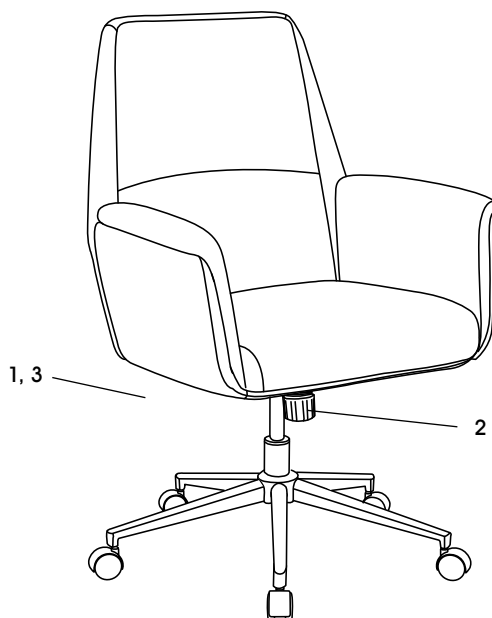

1. Hauteur du siège – Pour élever le siège, poussez le levier vers le bas avec peu ou sans poids sur le siège. Pour abaisser le siège, poussez le levier vers le bas en position assise.
2. Tension d'inclinaison – Pour augmenter la tension d'inclinaison, tournez la molette dans le sens horaire. Pour diminuer la tension d'inclinaison, tournez la molette dans le sens antihoraire.
3. Inclinaison avec blocage en position verticale – Pour bloquer le fauteuil en position verticale, poussez le levier vers le centre du siège. Pour rétablir l'inclinaison, tirez le levier vers l'extérieur. Le fauteuil comporte une inclinaison synchrone; l'angle d'inclinaison du dossier est de deux pour un par rapport à l'angle du siège.

**ULINE**

1-800-295-5510  
uline.ca