

ULINE H-10303

METRO COLLECTION – 2-DRAWER LATERAL FILE CABINET

1-800-295-5510
uline.com

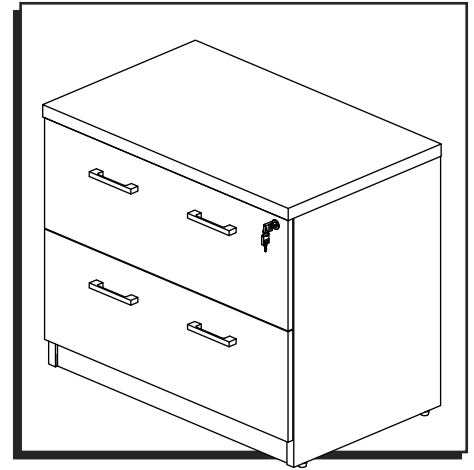

TOOLS NEEDED

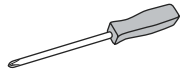

Phillips Screwdriver



Drill
(optional)



5/16" Drill Bit
(optional)



Two Person Assembly
Recommended

PARTS

A

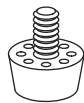

Adjustable Glide x 4

B

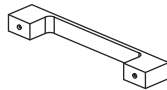

Handle x 4

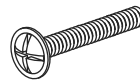

M4 x 34 mm Bolt x 8

L



File Clip x 8

M

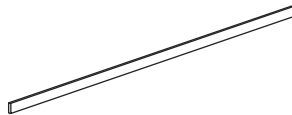

Long Metal Bar x 2

N



Short Metal Bar x 4

O



Key (Set of 2) x 1

R Wall Anchor Kit



Plastic Anchor x 2



Bracket x 2



M4 x 40 mm
Screw x 2



M4 x 20 mm
Screw x 2



Cable Tie x 1

ASSEMBLY

Figure 1

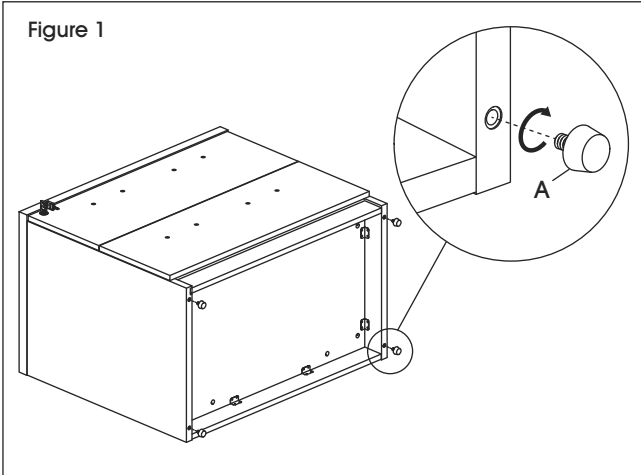

STOP! For H-10307 and H-11625 Storage Credenza assembly, refer to instructions included with H-10308 Storage Credenza Top/Frame.



NOTE: Assemble on a smooth, non-marring surface to avoid scratching.



NOTE: Check that all parts are included.

1. Lock drawers. With second person, carefully set file cabinet on back. (See Figure 1)
2. Insert adjustable glides (A) into bottom of file cabinet. Glides can be adjusted to compensate for uneven floors. (See Figure 1)
3. With second person, set file cabinet upright.
4. Unlock drawers. Remove handles (B) mounted inside drawer and use same bolts (M4 x 34 mm) to attach handles to front of drawer. Repeat for second drawer. (See Figure 2)

Figure 2

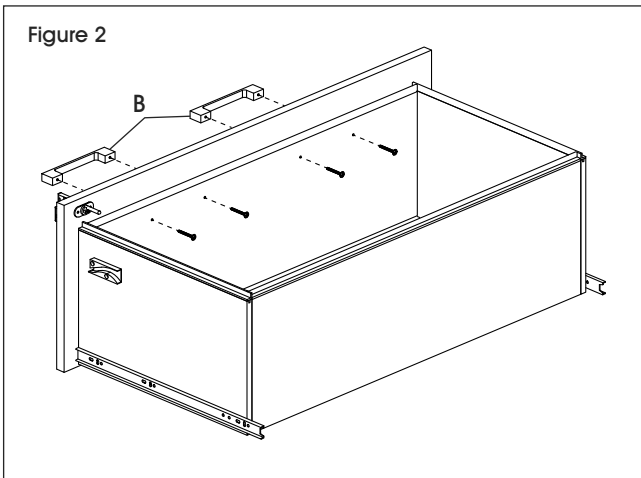
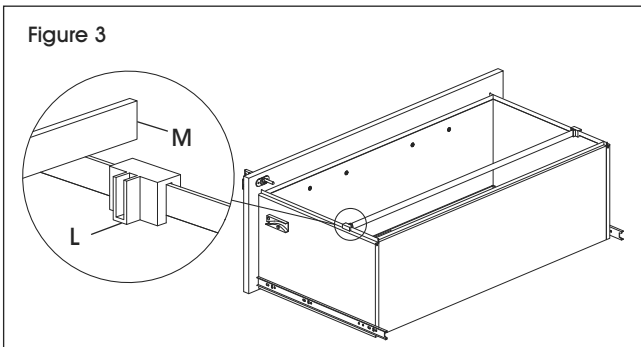
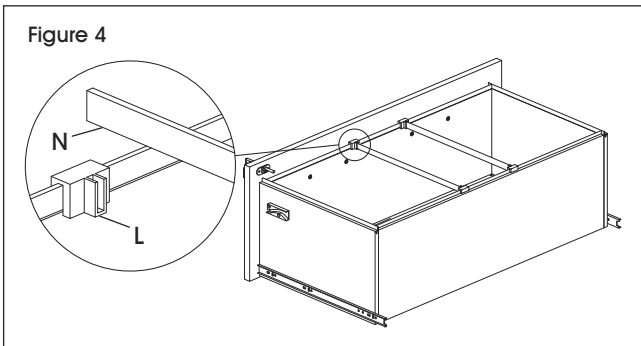

Figure 3



5. To hang files from side to side, attach one file clip (L) to each side of drawer and insert one long metal bar (M). (See Figure 3)

Figure 4



6. To hang files from front to back, attach one file clip (L) to front, and one to back end of drawer. Insert one short metal bar (N). (See Figure 4)

ASSEMBLY CONTINUED

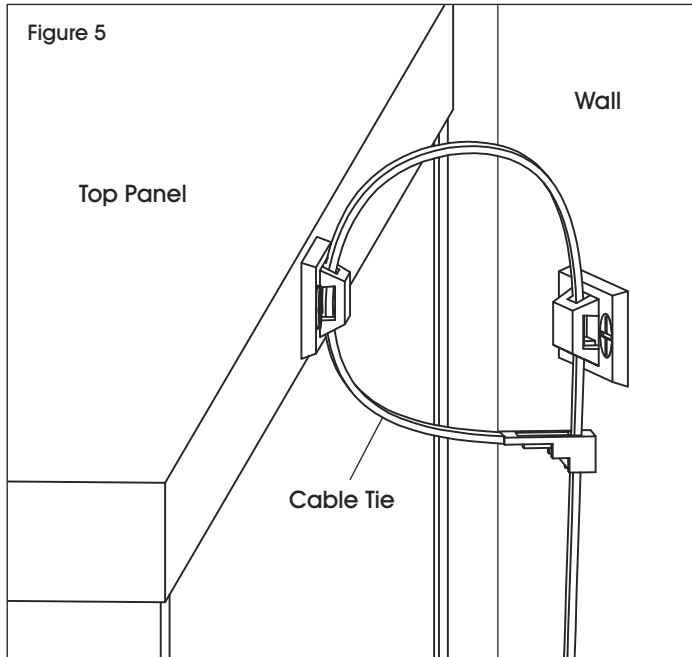

WALL ANCHOR

1. Attach one bracket of wall anchor to back of top of file cabinet using two M4 x 20 mm screws. (See Figure 5)
2. Using bracket as template, mark holes on wall where plastic anchors are to be located. Drill holes in wall using 5/16" drill bit. Insert two plastic anchors into previously drilled holes. Secure mount to wall with two M4 x 40 mm screws. (See Figure 5)
3. Loop cable tie through mounts and tighten. (See Figure 5)

ULINE

1-800-295-5510
uline.com

ULINE H-10303

COLECCIÓN URBANA – ARCHIVERO LATERAL DE 2 CAJONES

800-295-5510
uline.mx

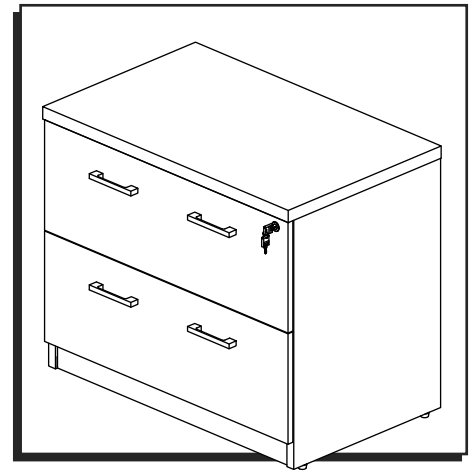

HERRAMIENTAS NECESARIAS

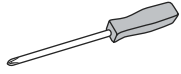

Desarmador de Cruz



Taladro
(opcional)



Broca de 5/16"
(opcional)



Se recomienda Armar
Entre Dos Personas

PARTES

A

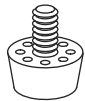

4 Tapas Niveladoras

B

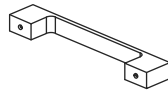

4 Asas

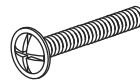

8 Pernos M4 x 34 mm

L



8 Clips para Archivo

M

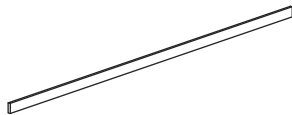

2 Barras Largas de Metal

N



4 Barras Cortas de Metal

O

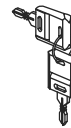

Llaves (Set de 2)

R Kit de Anclaje para Pared



2 Taquetes de Plástico



2 Soportes



2 Tornillos
M4 x 40 mm



2 Tornillos
M4 x 20 mm



1 Cincho

ENSAMBLE

Diagrama 1

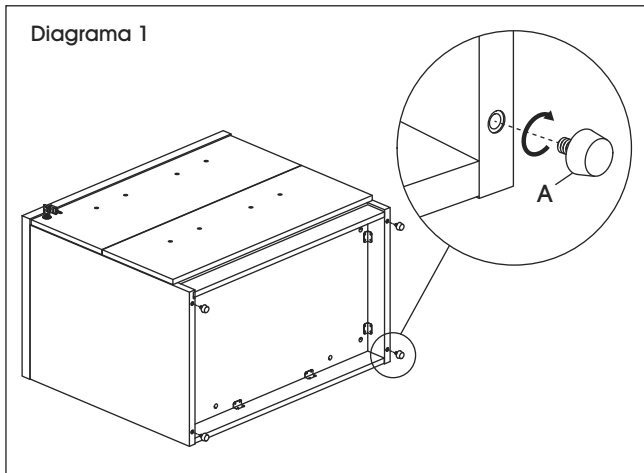

¡ALTO! Para el ensamble de la Credenza para Almacenamiento, consulte las instrucciones incluidas con la Cubierta/Armazón para Credenza de Almacenamiento H-10308 y H-11625.



NOTA: Ensamble sobre una superficie lisa que no deje marcas para evitar rayones.



NOTA: Verifique que todas las partes estén incluidas.

1. Cierre los cajones con llave. Entre dos personas, coloquen el archivero con cuidado en su parte posterior. (Vea Diagrama 1)
2. Inserte las tapas niveladoras (A) en la parte inferior del archivero. Las tapas niveladoras se pueden ajustar para compensar los pisos irregulares. (Vea Diagrama 1)
3. Entre dos personas enderecen el archivero.
4. Abra los cajones. Retire las asas (B) instaladas por dentro de los cajones y use los mismos pernos (M4 x 34 mm) para fijarlas al frente del cajón. Repita la operación para el segundo cajón. (Vea Diagrama 2)

Diagrama 2



Diagrama 3



5. Para colgar archivos de lado a lado, fije un clip (L) a cada lado del cajón e inserte una barra larga de metal (M). (Vea Diagrama 3)

Diagrama 4

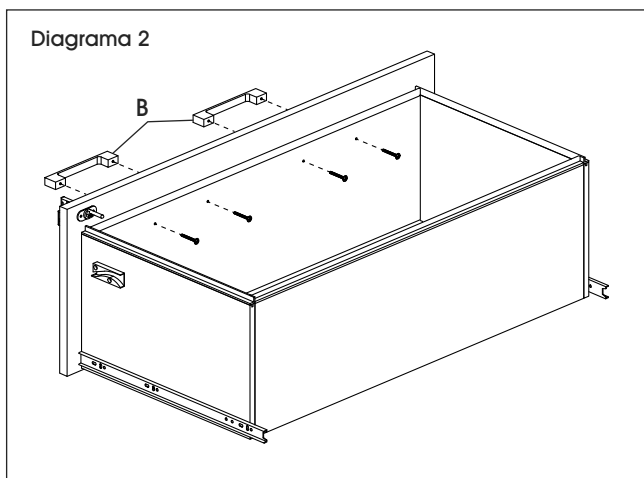
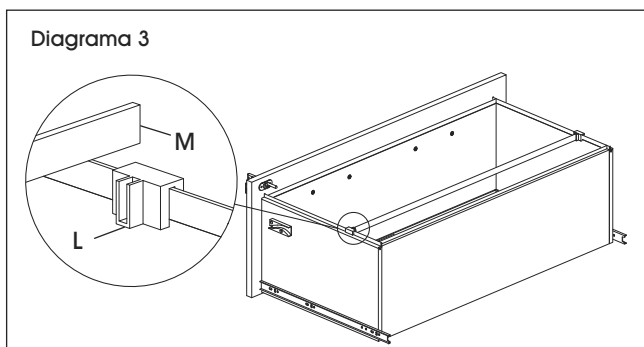
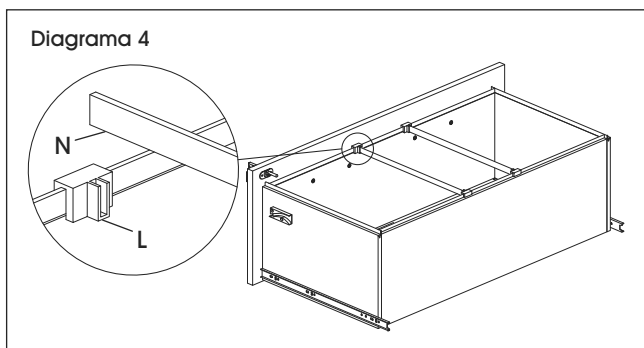

6. Para colgar archivos de frente hacia atrás, fije un clip (L) al lado frontal del cajón y uno al lado frontal del cajón. Inserte una barra corta de metal (N). (Vea Diagrama 4)

CONTINUACIÓN DEL ENSAMBLE

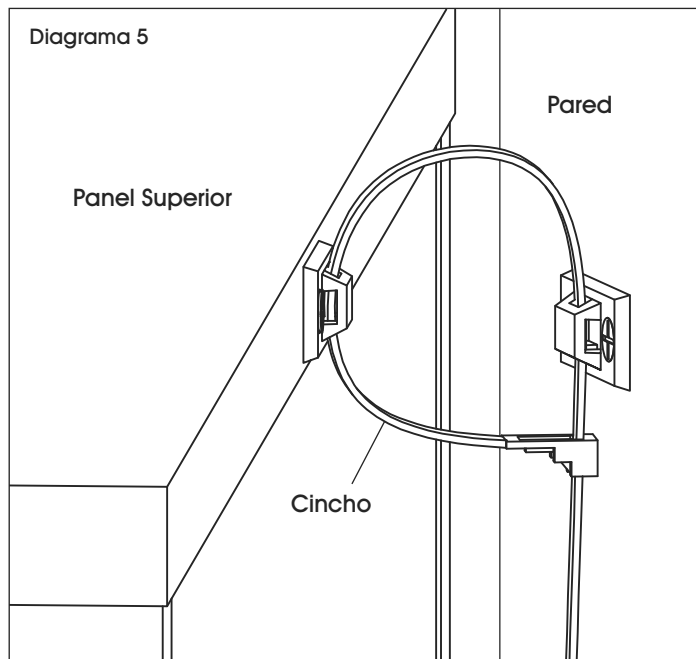

ANCLAJE PARA PARED

1. Fije un soporte del anclaje para pared a la parte posterior del archivero superior con dos tornillos M4 x 20 mm. (Vea Diagrama 5)
2. Utilizando un soporte como plantilla, marque los orificios en la pared donde se colocarán los taquetes de plástico. Taladre los orificios en la pared utilizando la broca de 5/16". Inserte dos de los taquetes de plástico dentro de los orificios preperforados. Fije el soporte a la pared con dos tornillos M4 x 40 mm. (Vea Diagrama 5)
3. Envuelva el cincho alrededor de los soportes y apriételo. (Vea Diagrama 5)

ULINE

800-295-5510
uline.mx

ULINE H-10303

COLLECTION METRO – CLASSEUR LATÉRAL À 2 TIROIRS

1 800 295-5510
uline.ca

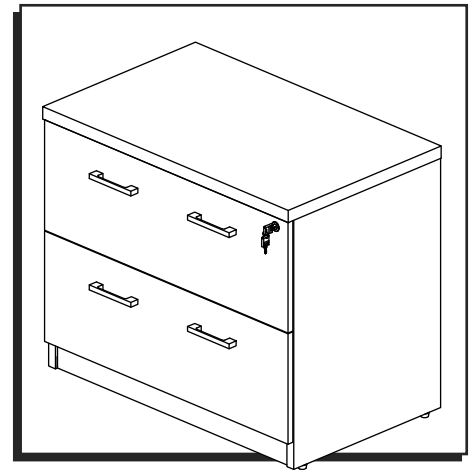

OUTILS REQUIS

 Montage à deux personnes recommandé

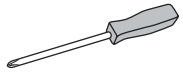

Tournevis cruciforme



Perceuse (optionnel)



Mèche de perceuse de 5/16 po (optionnel)

PIÈCES

A

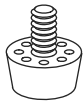

Patin réglable x 4

B

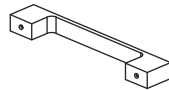

Poignée x 4

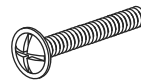

Boulon M4 x 34 mm x 8

L



Attache pour dossier x 8

M

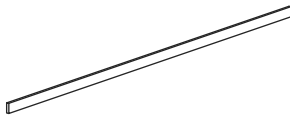

Barre métallique longue x 2

N



Barre métallique courte x 4

O

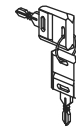

Clé (jeu de 2) x 1

R Ensemble d'ancrage mural



Ancrage en plastique x 2



Support x 2

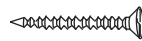

Vis M4 x 40 mm x 2



Vis M4 x 20 mm x 2

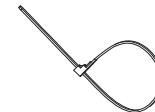

Attache-câble x 1

MONTAGE

Figure 1

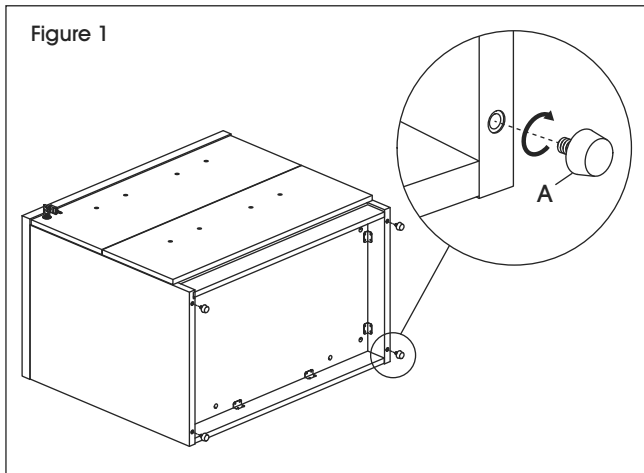

ARRÊT! Pour le montage du bahut de rangement H-10307, reportez-vous aux instructions fournies avec la surface/le cadre du bahut de rangement H-10308 et H-11625.



REMARQUE : Montez le classeur sur une surface lisse qui ne marque pas afin d'éviter les rayures.



REMARQUE : Vérifiez que toutes les pièces sont incluses.

1. Verrouillez les tiroirs. À deux, posez délicatement le classeur sur le dos. (Voir Figure 1)
2. Insérez les patins réglables (A) sous le classeur. Les patins peuvent être réglés pour compenser les inégalités des planchers. (Voir Figure 1)
3. À deux, posez le classeur à la verticale.
4. Déverrouillez les tiroirs. Retirez les poignées (B) situées à l'intérieur du tiroir et fixez-les à l'extérieur avec les mêmes boulons (M4 x 34 mm). Répétez l'opération pour le deuxième tiroir. (Voir Figure 2)

Figure 2

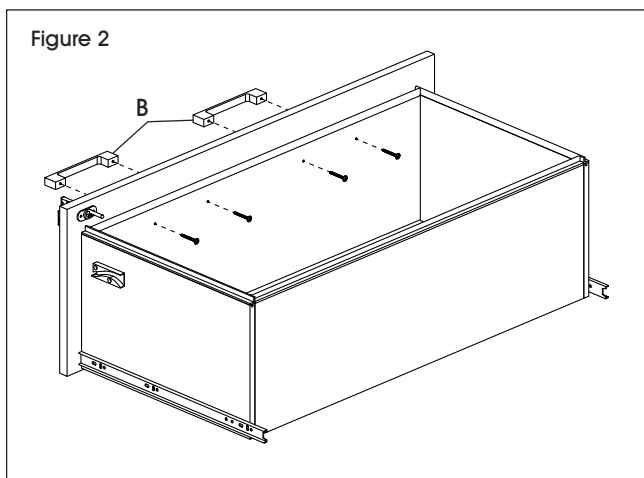
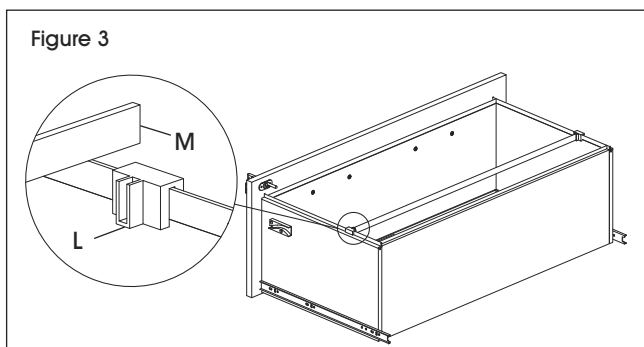
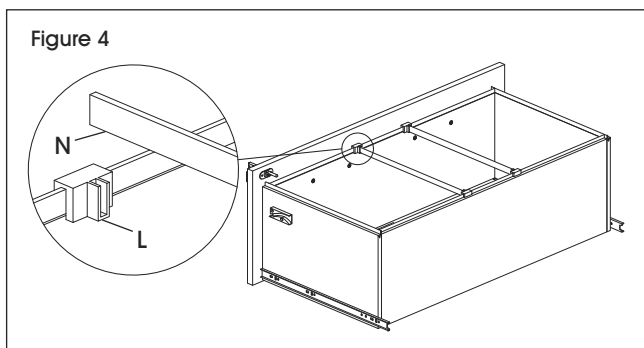

Figure 3



5. Pour suspendre les dossiers latéralement, fixez une attache pour dossier (L) sur chaque côté du tiroir et insérez une barre métallique longue (M). (Voir Figure 3)

Figure 4



6. Pour suspendre les dossiers transversalement, fixez une attache pour dossier (L) à l'avant et une à l'arrière du tiroir. Insérez une barre métallique courte (N). (Voir Figure 4)

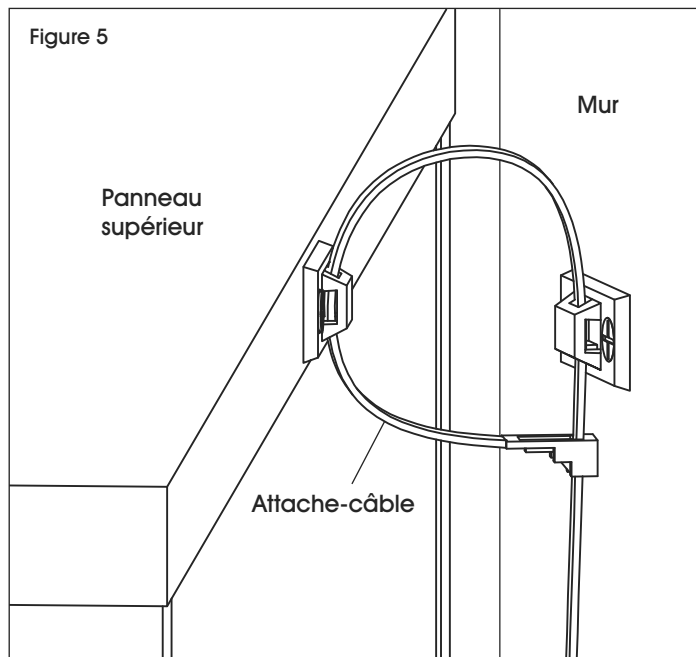

ANCRAGE MURAL

1. Fixez un support d'ancrage mural sur la partie supérieure arrière du classeur avec deux vis M4 x 20 mm. (Voir Figure 5)
2. En utilisant le support comme modèle, marquez l'emplacement des trous sur le mur pour les ancrages en plastique. Percez les trous dans le mur avec une mèche de perceuse de 5/16 po. Insérez deux ancrages en plastique dans les trous prépercés. Fixez le support au mur avec deux vis M4 x 40 mm. (Voir Figure 5)
3. Faites passer l'attache-câble à travers les supports et serrez-le. (Voir Figure 5)