

ULINE H-10306, H-10307
 H-11625

1-800-295-5510
 uline.com

METRO COLLECTION

STORAGE CREDENZA

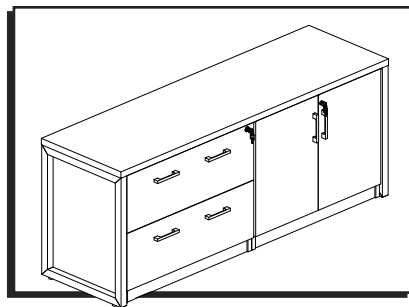

TOOLS NEEDED

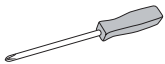

Phillips
Screwdriver



Rubber Mallet



Drill
(Optional)



5/16" Drill Bit
(Optional)



Allen Wrench
(Optional)



Three Person Assembly
Recommended

STORAGE CABINET PARTS

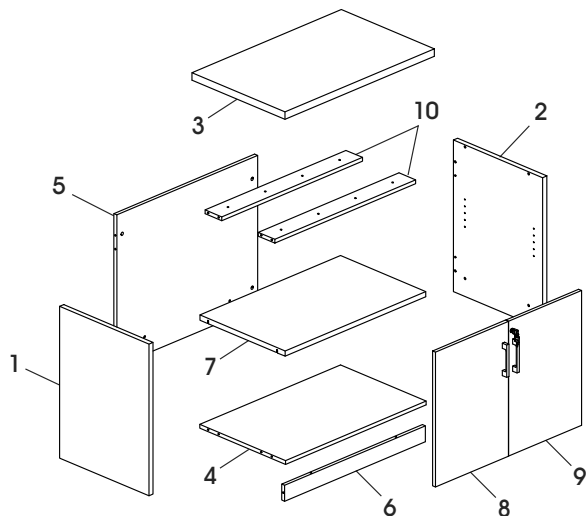

STORAGE CABINET PARTS

#	DESCRIPTION	QTY
1	Left Side Panel	1
2	Right Side Panel	1
3	Top Panel	1
4	Bottom Panel	1
5	Back Panel	1
6	Skirt Panel	1
7	Shelf	1
8	Left Door	1
9	Right Door	1
10	Support Beam	2



Adjustable Glide x 4

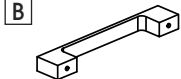

Metal Handle x 2



M4 x 22 mm Bolt x 4



M6 x 30 mm Bolt x 8

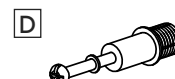

Cam Lock Pin x 17

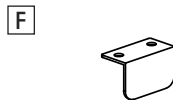

L-Bracket x 1



S-Bracket x 1



M3 x 16 mm Screw x 4



Lock x 1



M3.5 x 14 mm Screw x 2



Cam Lock x 17

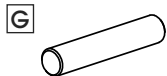

Dowel x 12



Shelf Dowel x 4



Cam Lock Cap x 17



Door Plug x 1

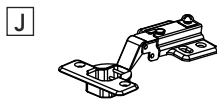

Hinge x 4



M4 x 10 mm Bolt x 8



M4 x 14 mm Screw x 16

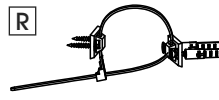

Wall Anchor Kit x 1

LATERAL FILE PARTS

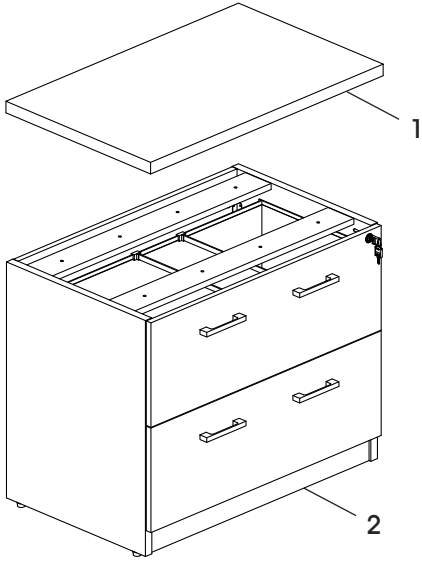

LATERAL FILE PARTS

#	DESCRIPTION	QTY
1	Top Panel	1
2	Cabinet	1

A



Adjustable Glide x 4

B

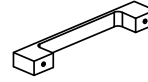

Metal Handle x 2

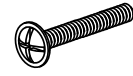

M4 x 34 mm Bolt x 8

C

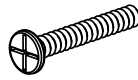

M6 x 30 mm Bolt x 8

L



File Clip x 8

M

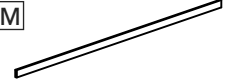

Long Metal Bar x 2

N



Short Metal Bar x 4

O



Key (Set of 2) x 1

R

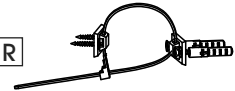

Wall Anchor Kit x 1

CREDENZA PARTS

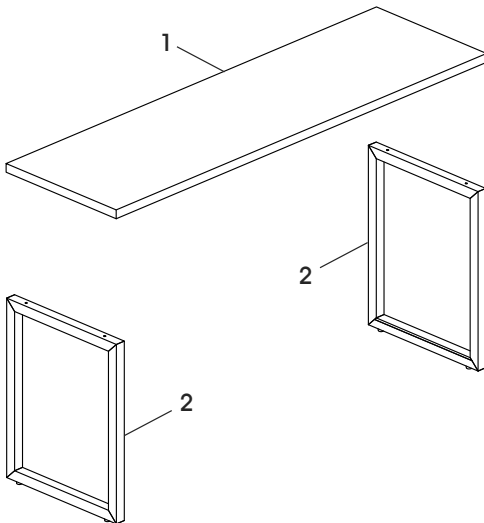

CREDENZA PARTS

#	DESCRIPTION	QTY
1	Credenza Top Panel	1
2	Steel Leg	2

A



Adjustable Glide x 4

P

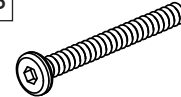

M6 x 55 mm Bolt x 4

Q



Flat Bracket x 6

STORAGE CABINET



If assembling H-10306 or H-10307, open H-10295 carton first to assemble storage cabinet in steps 1-11. If assembling H-11625, open H-10303 carton and proceed to lateral file assembly on page 5.



IMPORTANT! Turn cam lock 1/4 to the right to lock.



IMPORTANT! Cam lock pins must be tightened once inserted into panel. To tighten cam lock

IMPORTANT! FUNCTION OF CAM LOCK

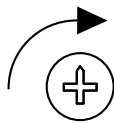

1/4 RIGHT TURN
FOR LOCKING

Ensure the arrow is pointing toward edge of panel before inserting into the panel's hole.

pins, grasp lower part of cam lock pin and tighten using a Phillips screwdriver.

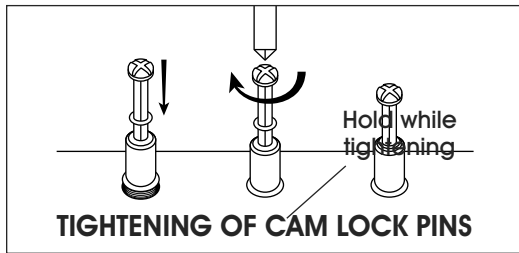

NOTE: Use Phillips screwdriver to tighten cam locks, cam lock pins and screws.



NOTE: Cam lock caps (I) can be applied once cam locks are tightened for a finished look.

1. Install one cam lock pin (D) in bottom panel (4). Insert one cam lock (E) into corresponding hole in skirt panel (6). Fit bottom panel and skirt panel together and tighten cam lock. (See Figure 1)

Figure 1

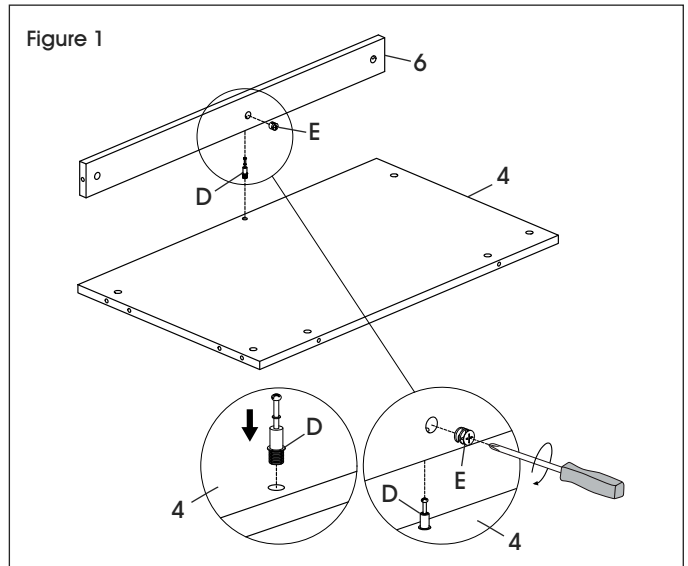

2. Install two cam lock pins (D) and two dowels (G) in back panel (5). Insert two cam locks (E) into corresponding holes in bottom panel (4). Fit back panel and bottom panel together and tighten cam locks. (See Figure 2)

Figure 2

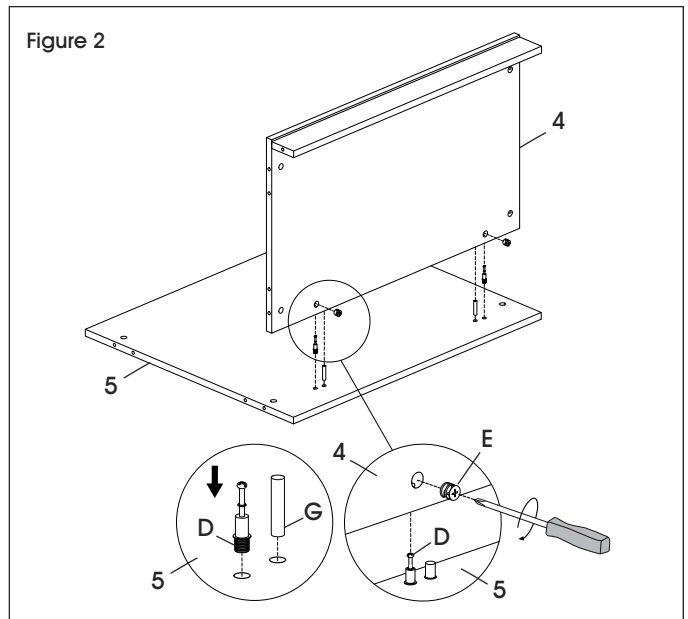

ASSEMBLY CONTINUED

- Install seven cam lock pins (D) and six dowels (G) in left side panel (1). Insert seven cam locks (E) into corresponding holes in back panel (5), bottom panel (4), skirt panel (6) and top support beams (10). Fit left side panel together with back panel, bottom panel, skirt panel and top support beams and tighten cam locks. Repeat for right side panel (2). (See Figure 3)

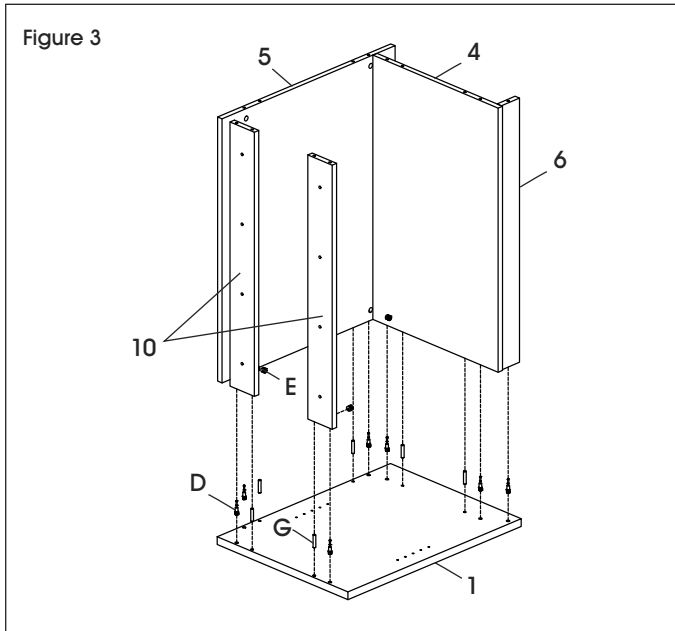

- Set cabinet upright. Insert four shelf dowels (H) into desired hole locations in side panels (1, 2). Place shelf (7) inside cabinet and ensure shelf supports lower onto shelf dowels. Tighten shelf supports in underside of shelves for a secure fit. (See Figure 4)

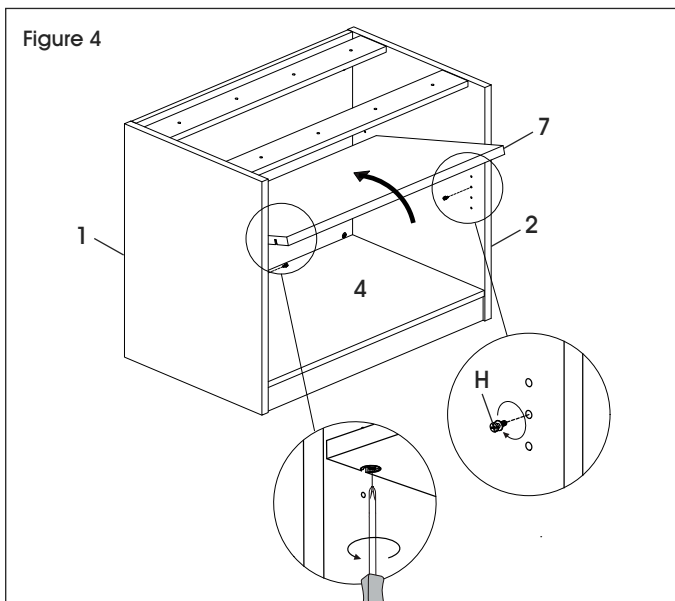

- Place left door (8) and right door (9) panels on a smooth, non-marring surface to prevent scratching. Align holes in hinge (J) with pre-drilled holes in door panels. Insert two M4 x 10 mm bolts (J) and tighten. Repeat for three remaining hinges. (See Figure 5)
- Attach handles (B) to the outside of the door panels using four M4 x 22 mm bolts (B). (See Figure 5)
- Align holes on S-bracket (F) with pre-drilled holes in top of left door (8). Insert two M3 x 16 mm screws (F) and tighten. (See Figure 5)
- Align holes on lock (F) with pre-drilled holes in right door (9). Insert two M3.5 x 14 mm screws (F) and tighten. (See Figures 5-6)

 **NOTE:** Refer to Figure 6 for correct orientation of lock.

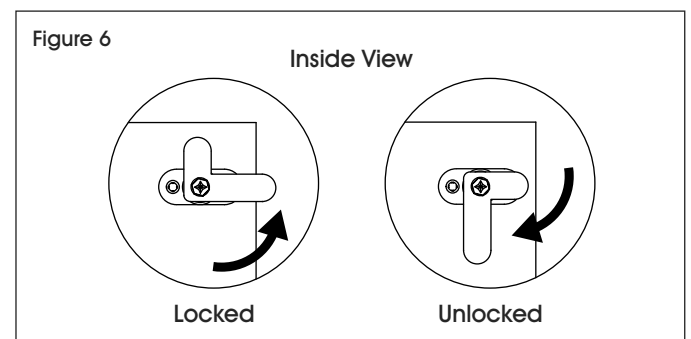
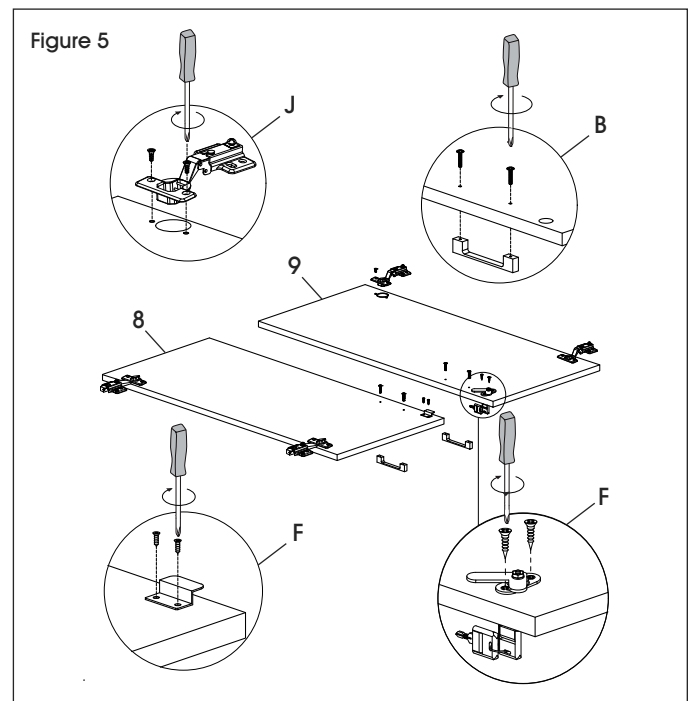

ASSEMBLY CONTINUED

9. Using two people, hold door panel in line with side panel. Attach hinge (J) to inside of side panel using four M4 x 14 mm screws (J). Repeat for three remaining hinges. (See Figure 7)

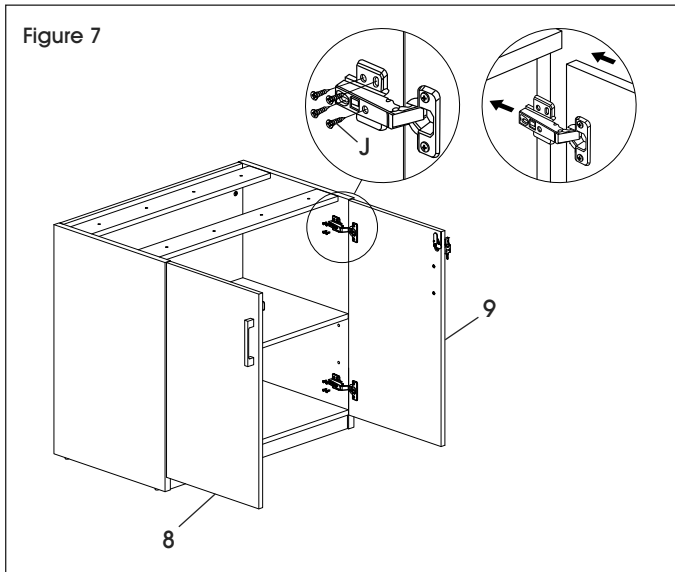

10. Once door panels are attached, hinges may need to be adjusted to align the doors. To adjust the depth of the doors, tighten or loosen the rear screw in the hinge. To adjust the angle of the doors, tighten or loosen the center screw in the hinge. (See Figure 8)

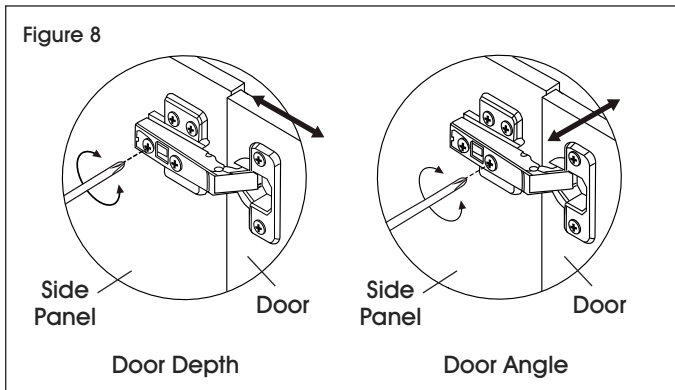

11. Storage cabinet top from H-10295 carton will not be used and can be discarded. Set assembled storage cabinet aside.



STOP! If assembling H-10306 double cabinet credenza, repeat storage cabinet assembly to build second cabinet. Then proceed to credenza assembly on page 6.

If assembling H-10307 lateral file and cabinet credenza or H-11625 double lateral file credenza, open H-10303 and follow lateral file assembly below.

LATERAL FILE ASSEMBLY

1. Remove handle (B) mounted inside drawer and use same bolts (M4 x 34 mm) to attach handle to front of drawer. Repeat for all handles. (See Figure 9)

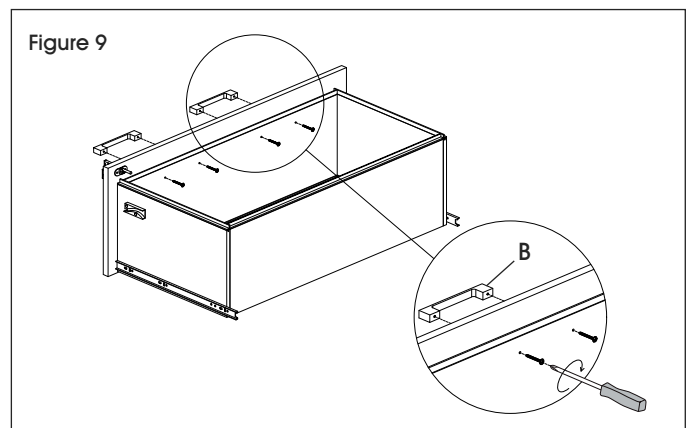

2. Remove top drawer by pressing on plastic tabs on drawer slides and pulling out. (See Figure 10)

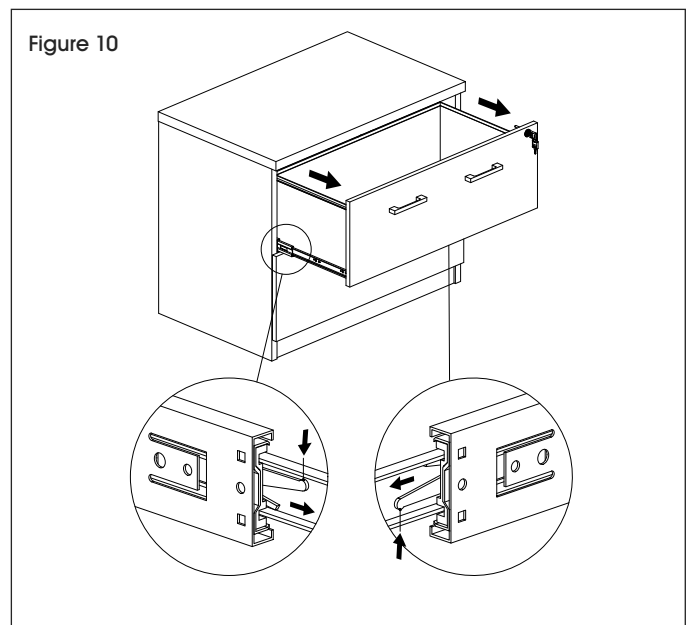

ASSEMBLY CONTINUED

3. Remove top panel (1) by taking out eight M6 x 30 mm bolts (C) using Phillips screwdriver. Save bolts for credenza top frame construction. Top panel will not be used and can be discarded. Set assembled lateral file cabinet aside. (See Figure 11)

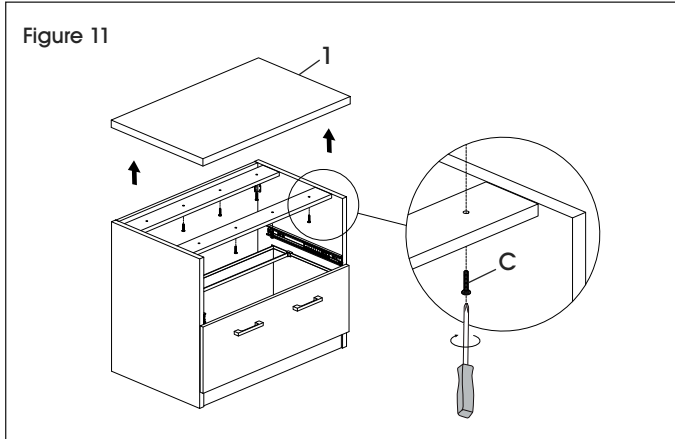

STOP STOP! If assembling H-11625 double lateral file credenza, repeat lateral file assembly to build second lateral file. Then proceed to credenza assembly.

CREDENZA ASSEMBLY

STOP STOP! Open H-10308 carton to assemble credenza in steps 1-7.

NOTE: If assembling H-10306 double cabinet credenza or H-11625 double lateral file credenza, the same instructions will be followed for steps 1-6. Figures only show a lateral file and cabinet credenza.

NOTE: Position cabinets near desired location. It is difficult to move the credenza when fully assembled.

1. With second person, carefully set cabinets on back.

NOTE: If assembling H-10307 lateral file and cabinet credenza, cabinets can be configured on either side. Figures show lateral file on left and storage cabinet on right.

2. Align two flat brackets (Q) with holes on underside of cabinets. Insert four adjustable glides (A) through brackets and tighten to connect lateral file and storage cabinet. (See Figure 12)

Figure 12

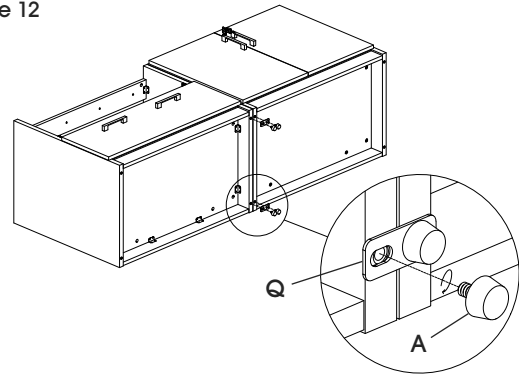

3. Position steel legs (2) on sides of cabinets. Align flat brackets (Q) with underside of cabinets and steel leg. Insert eight adjustable glides (A) through brackets and tighten to connect cabinets to steel legs. With three people, carefully lift both cabinets upright simultaneously. (See Figure 13)

Figure 13

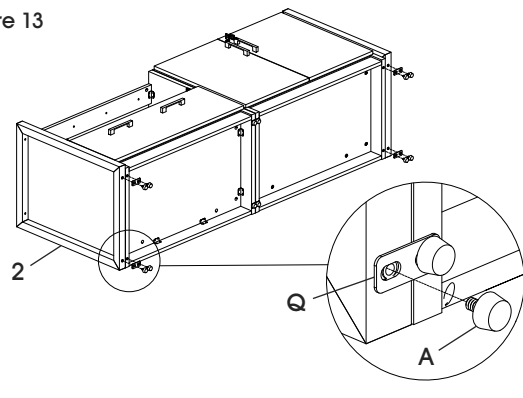

ASSEMBLY CONTINUED

4. If assembling H-10306 or H-10307, align holes on L-bracket (F) with pre-drilled holes in credenza top panel (1) on the storage cabinet side. Insert two M3 x 16 mm screws (F) and attach using a Phillips screwdriver or drill. Align holes on door plug (K) with pre-drilled holes in top panel and gently tap with rubber mallet to insert. Repeat on opposite side if assembling H-10306 double cabinet credenza. (See Figure 14)

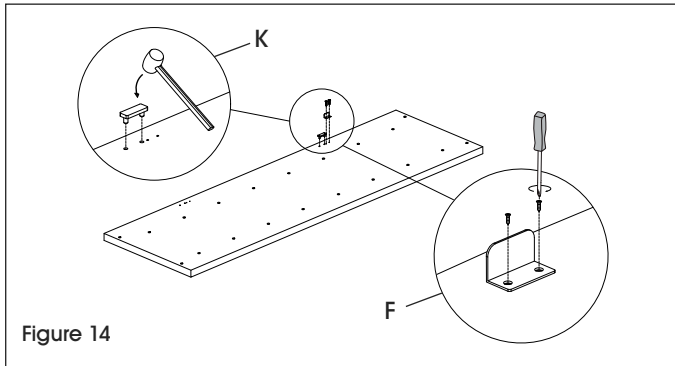

Figure 14

5. Attach credenza top panel to frame legs using four M6 x 55 mm bolts (P). (See Figure 15)

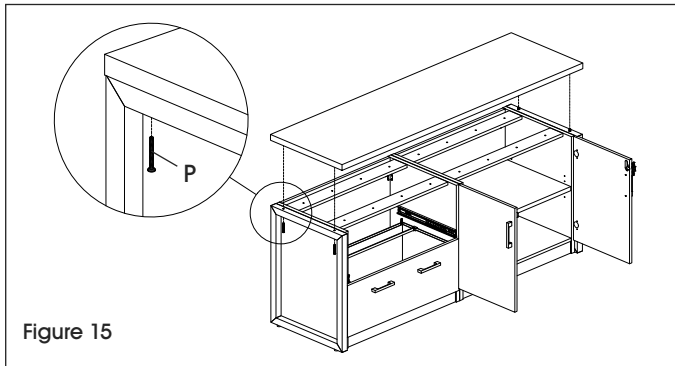

Figure 15

6. Attach credenza top panel to support beams in cabinets using 16 M6 x 30 mm bolts (C). (See Figure 16)

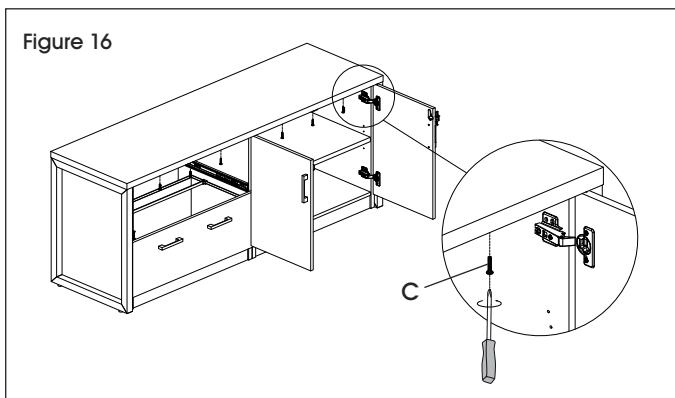

Figure 16



STOP! Steps 7-9 only apply if assembling the H-10307 lateral file and cabinet credenza or H-11625 double lateral file credenza. Otherwise, proceed to step 10.

7. Reattach top drawer of lateral file. (See Figure 17)

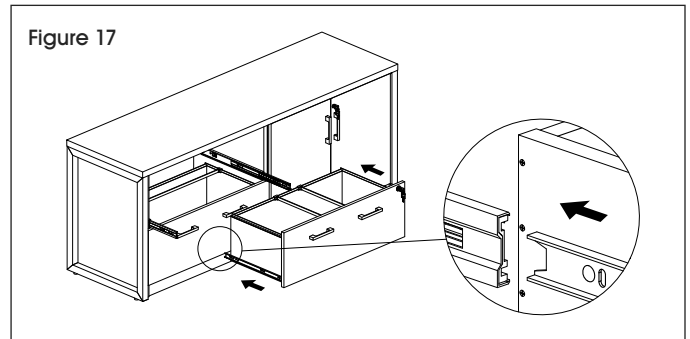

Figure 17

8. To hang files from side to side, attach one file clip (L) to each side of drawer and insert one long metal bar (M). (See Figure 18)

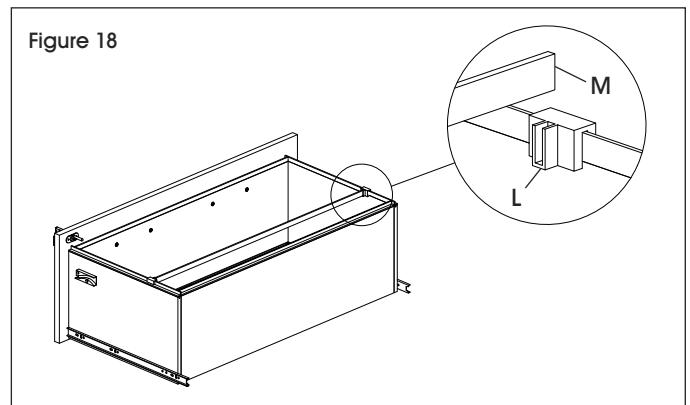

Figure 18

9. To hang files from front to back, attach two file clips (L) to back of drawer and two to front of drawer and insert two short metal bars (N). (See Figure 19)

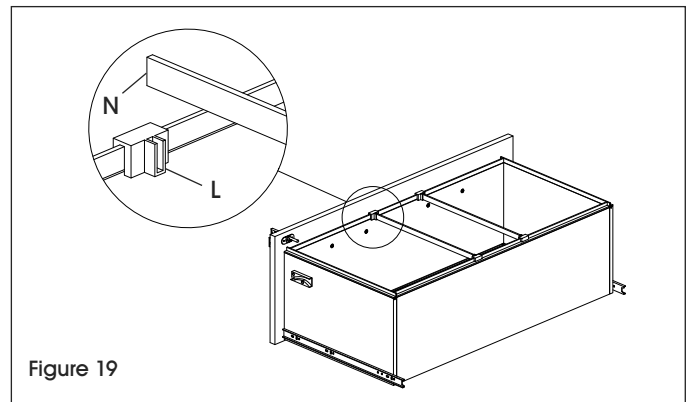
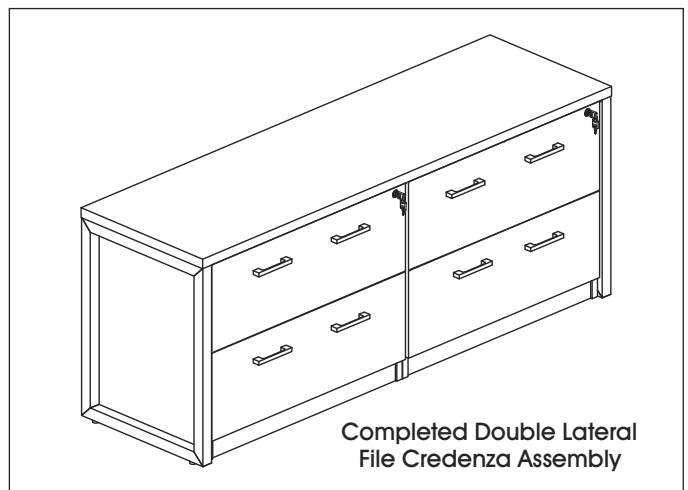
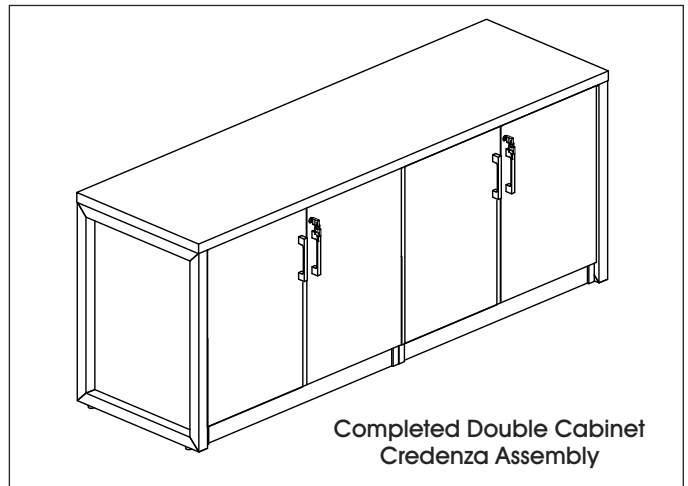
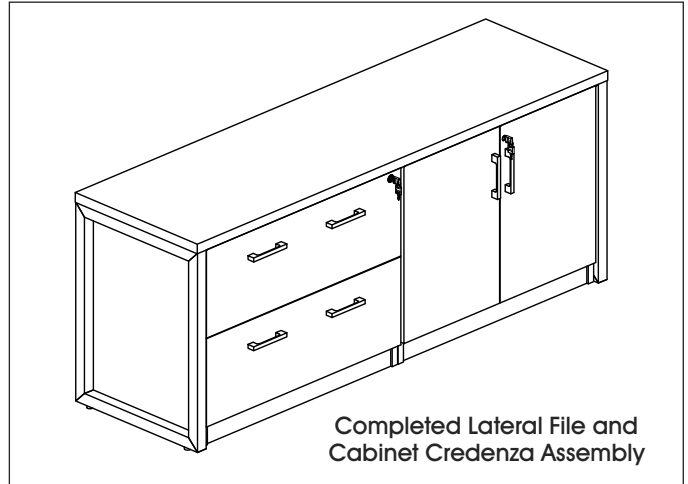
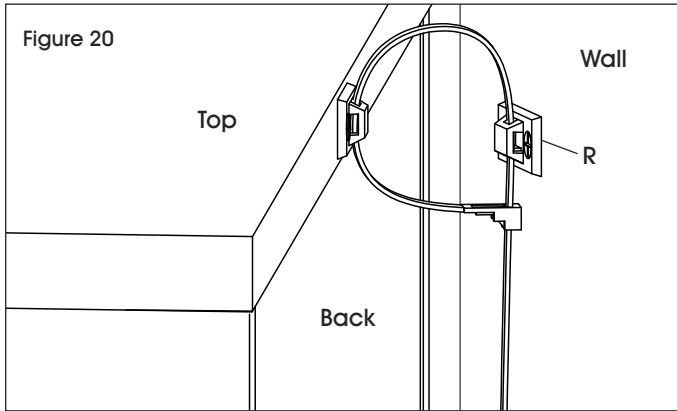

Figure 19

ASSEMBLY CONTINUED

10. Attach one bracket of wall anchor (R) to back of top of credenza using two M4 x 20 mm screws. Mark holes on wall where plastic anchors are to be located. Drill holes using 5/16" drill bit. Mount opposite bracket of wall anchor to wall with two M4 x 40 mm screws and two plastic anchors. Tighten cable tie to prevent tipping. Repeat for opposite side of credenza. (See Figure 20)



ULINE

1-800-295-5510
uline.com

COLECCIÓN METROPOLITANA

CREDENZA PARA ALMACENAMIENTO

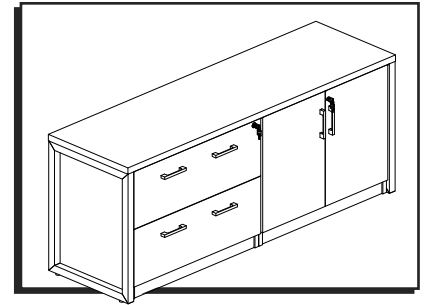

HERRAMIENTAS NECESARIAS

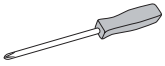

Desarmador de Cruz



Mazo de Caucho



Taladro (Opcional)



Broca de 5/16" (Opcional)



Llave Allen (Opcional)



Se recomienda Armar Entre Tres Personas

PARTES DEL GABINETE PARA ALMACENAMIENTO

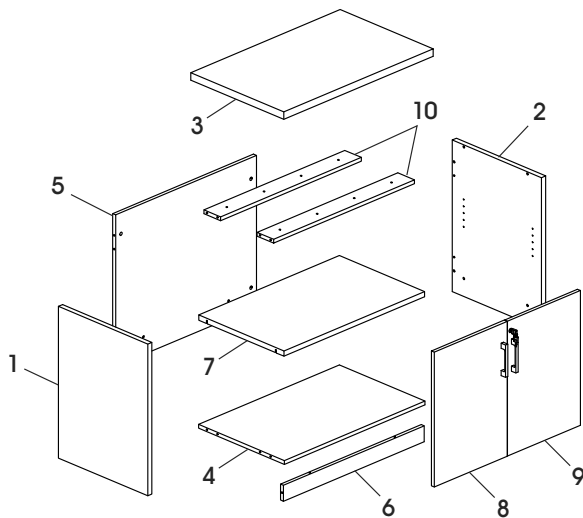

PARTES DEL GABINETE PARA ALMACENAMIENTO

#	DESCRIPCIÓN	CANT.
1	Panel Lateral Izquierdo	1
2	Panel Lateral Derecho	1
3	Panel Superior	1
4	Panel Inferior	1
5	Panel Posterior	1
6	Moldura	1
7	Repisa	1
8	Puerta Izquierda	1
9	Puerta Derecha	1
10	Viga de Soporte	2



4 Tapas Niveladoras

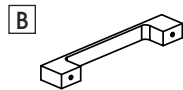

2 Asas de Metal

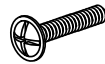

4 Pernos M4 x 22 mm

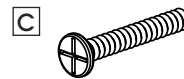

8 Pernos M6 x 30 mm

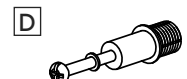

17 Pasadores para Tuercas Minifix



1 Soporte en L



1 Soporte en S



4 Tornillos M3 x 16 mm



1 Cerradura



2 Tornillos M3.5 x 14 mm



17 Tuercas Minifix

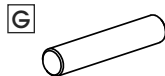

12 Taquetes



4 Taquetes para Repisa

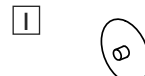

17 Tapas para Tuercas Minifix

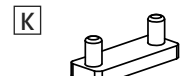

1 Tapón para Puerta

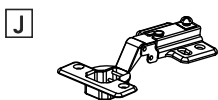

4 Bisagras



8 Pernos M4 x 10 mm



16 Tornillos M4 x 14 mm

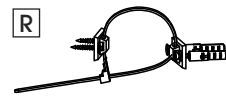

1 Kit de Anclaje para Pared

PARTES DEL ARCHIVERO LATERAL

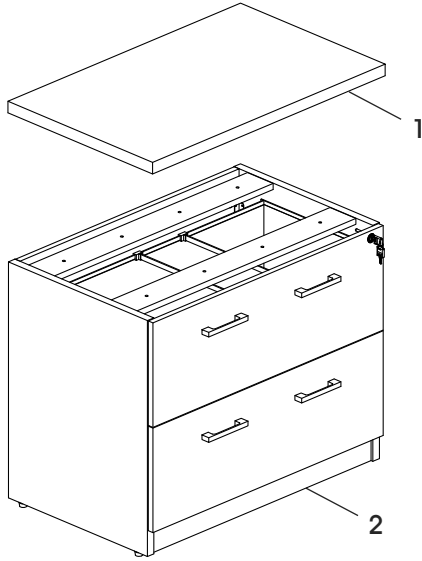

PARTES DEL ARCHIVERO LATERAL

#	DESCRIPCIÓN	CANT.
1	Panel Superior	1
2	Gabinete	1

A



4 Tapas Niveladoras

B

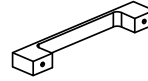

2 Asas de Metal

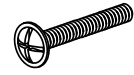

8 Pernos M4 x 34 mm

C



8 Pernos M6 x 30 mm

L



8 Clips para Archivo

M



2 Barras Largas de Metal

N



4 Barras Cortas de Metal

O



Llaves (Set de 2)

R



1 Kit de Anclaje para Pared

PARTES DE LA CREDENZA

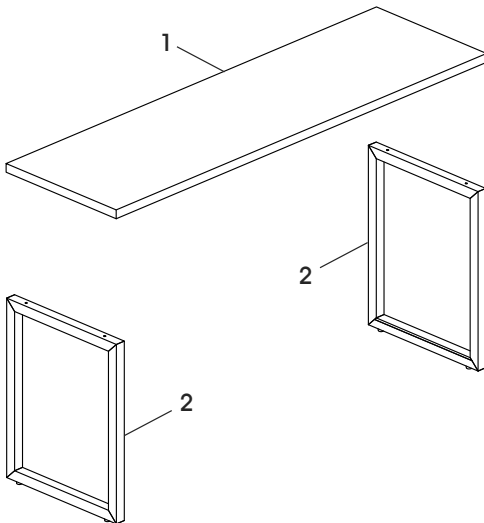

PARTES DE LA CREDENZA

#	DESCRIPCIÓN	CANT.
1	Panel Superior de la Credenza	1
2	Pata de Acero	2

A



12 Tapas Niveladoras

P

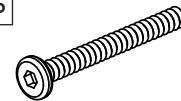

4 Pernos M6 x 55 mm

Q

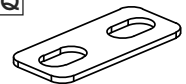

6 Soportes Planos

GABINETE DE ALMACENAMIENTO



Si ensambla el H-10306 o H-10307, abra primero la caja H-10295 para ensamblar el gabinete de almacenamiento con los pasos 1-11. Si ensambla el H-11625, abra la caja H-10303 y proceda al ensamble del archivero lateral en la página 13.



¡IMPORTANTE! Gire la tuerca minifix 1/4 a la derecha para asegurarla.

¡IMPORTANTE! FUNCIÓN DE LA TUERCA MINIFIX

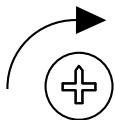

GÍRELA 1/4 DE POSICIÓN A LA DERECHA PARA ASEGURARLA

Asegúrese de que la flecha apunte al borde del panel antes de insertarla en el orificio del panel.



¡IMPORTANTE! Los pasadores para tuercas minifix se deben apretar una vez que se hayan insertado en el panel. Para apretar los pasadores para tuercas minifix, sostenga la parte inferior del pasador y apriete con el desarmador de cruz.

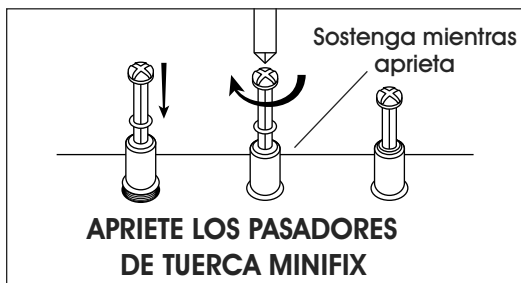

NOTA: Use un desarmador de cruz para apretar las tuercas minifix, pasadores para tuerca minifix y tornillos.



NOTA: Puede colocar las tapas de las tuercas minifix (I) cuando las haya apretado para darle una apariencia terminada.



¡IMPORTANTE! Algunas partes están etiquetadas con las mismas letras o números para el gabinete para almacenamiento, archivero lateral y el armazón de la credenza. Consulte el diagrama asociado con cada paso para usar las partes correctas.

1. Instale un pasador para tuerca minifix (D) en el panel inferior (4). Inserte una tuerca minifix (E) en el orificio correspondiente de la moldura (6). Junte el panel inferior con la moldura y apriete la tuerca minifix. (Vea Diagrama 1)

Diagrama 1

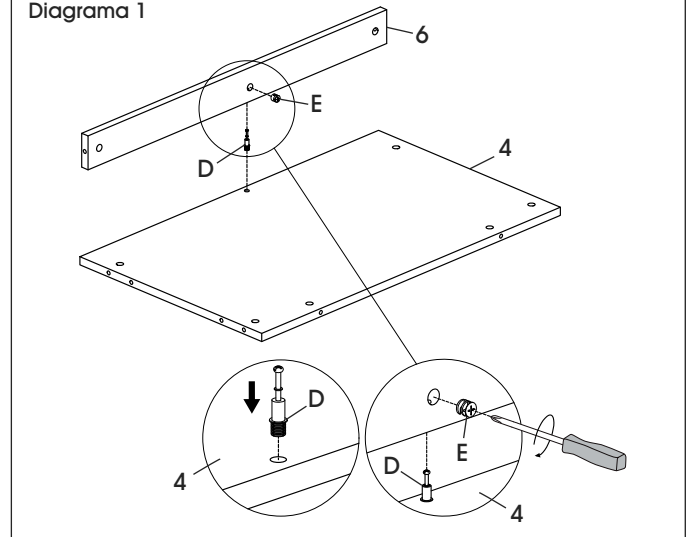

2. Instale dos pasadores para tuercas minifix (D) y dos taquetes (G) en el panel posterior (5). Inserte dos tuercas minifix (E) en los orificios correspondientes del panel inferior (4). Junte los paneles posterior e inferior y apriete las tuercas minifix. (Vea Diagrama 2)

Diagrama 2

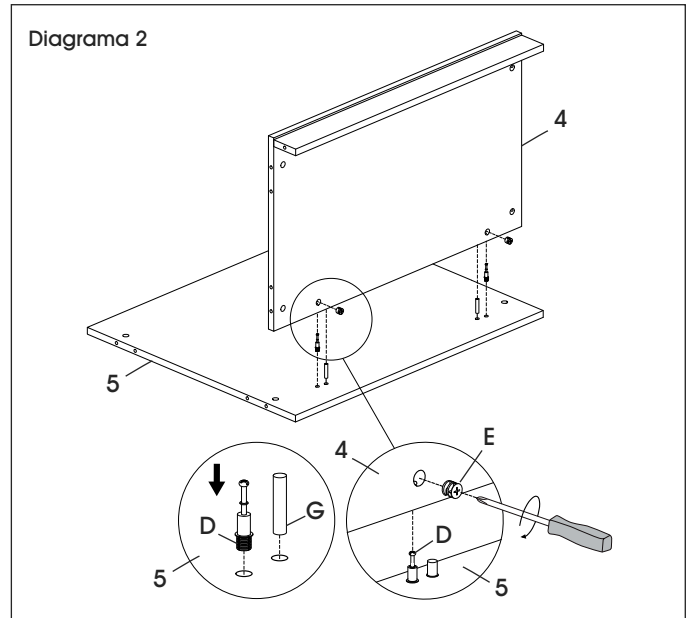

CONTINUACIÓN DEL ENSAMBLE

3. Instale siete pasadores para tuercas minifix (D) y seis taquetes (G) en el panel lateral izquierdo (1). Inserte las siete tuercas minifix (E) en los orificios correspondientes en el panel posterior (5), panel inferior (4), moldura (6) y las vigas de soporte frontal (10). Junte el panel lateral izquierdo con el panel posterior, panel inferior, moldura y vigas de soporte superior y apriete las tuercas minifix. Repita la operación con el panel lateral derecho (2). (Vea Diagrama 3)

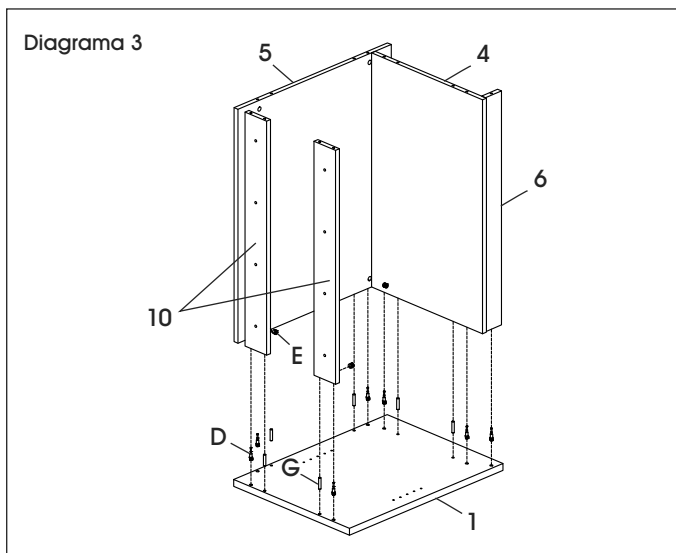

4. Levante el gabinete. Inserte cuatro taquetes para repisa (H) en las ubicaciones deseadas de los orificios de los paneles laterales (1, 2). Coloque la repisa (7) dentro del gabinete y asegúrese de que los soportes para repisa descansen sobre los taquetes. Apriete los soportes de las repisas debajo de ellas para un ajuste seguro. (Vea Diagrama 4)

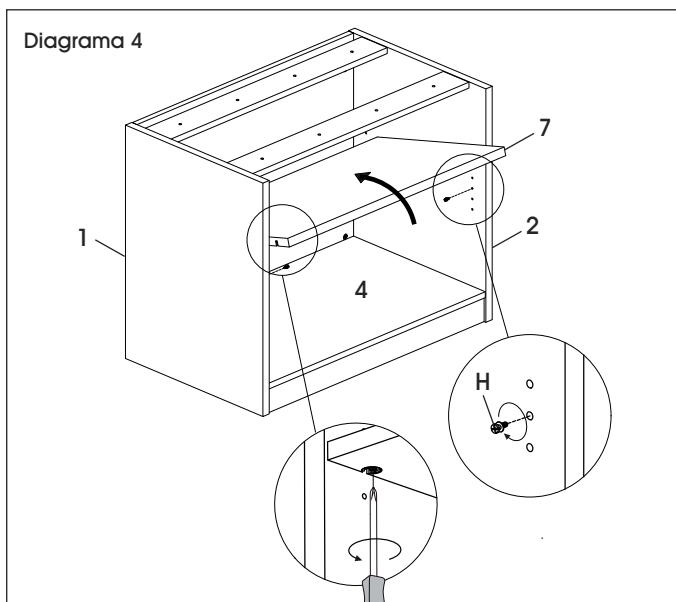

5. Coloque los paneles de la puerta izquierda (8) y derecha (9) sobre una superficie lisa que no deje marcas para evitar rayones. Alinee los orificios en la bisagra (J) con los orificios preperforados en los paneles de las puertas. Inserte dos pernos M4 x 10 mm (J) y apriételes. Repita la operación en las tres bisagras restantes. (Vea Diagrama 5)
6. Fije las asas (B) al exterior de los paneles de puerta utilizando cuatro pernos M4 x 22 mm (B). (Vea Diagrama 5)
7. Alinee los orificios en el Soporte en S (F) con los orificios preperforados en el puerta izquierda superior (8). Inserte dos pernos M3 x 16 mm (F) y apriete. (Vea Diagrama 5)
8. Alinee los orificios del seguro (F) con los orificios preperforados de la puerta derecha (9). Inserte dos pernos M3.5 x 14 mm (F) y apriete. (Vea Diagramas 5 a 6)



NOTA: Consulte el Diagrama 6 para ver la orientación correcta para cerrar.

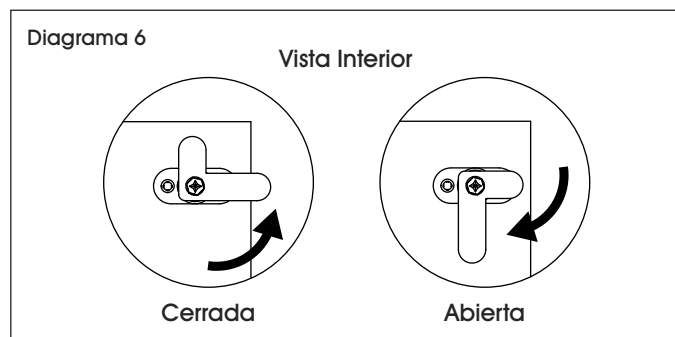
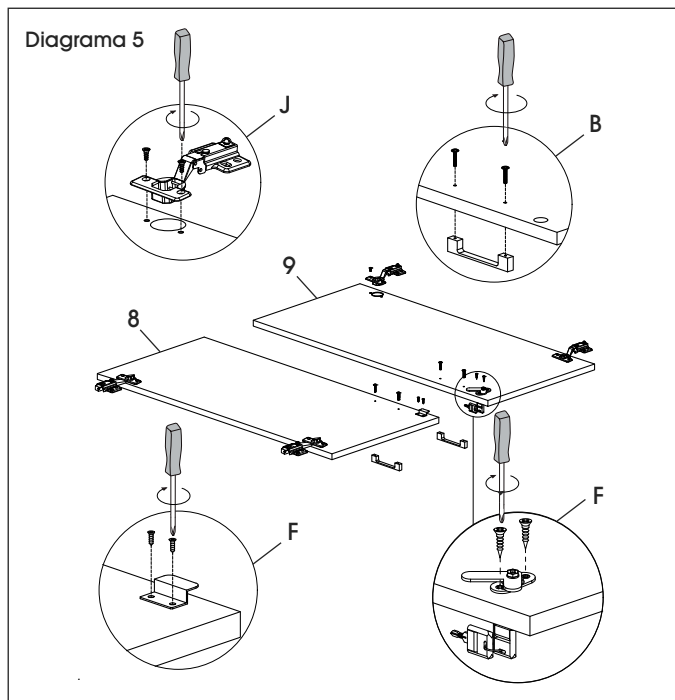

CONTINUACIÓN DEL ENSAMBLE

9. Entre dos personas, alinee el panel de la puerta con el panel lateral. Fije la bisagra (J) a la parte interior del panel lateral utilizando cuatro tornillos M4 x 14 mm (J). Repita la operación en las tres bisagras restantes. (Vea Diagrama 7)

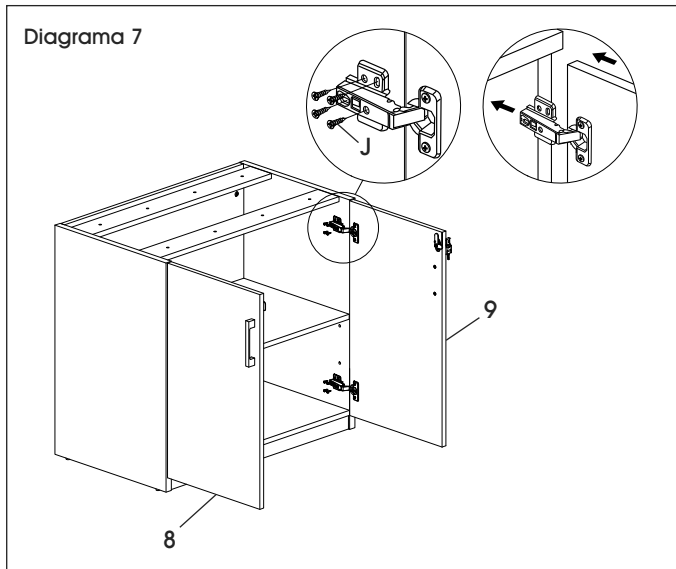

10. Cuando los paneles de las puertas estén unidos, las bisagras pueden necesitar ajuste para alinear las puertas. Para ajustar la profundidad de las puertas, apriete o afloje el tornillo posterior en la bisagra. Para ajustar el ángulo de las puertas, apriete o afloje el tornillo central en la bisagra. (Vea Diagrama 8)

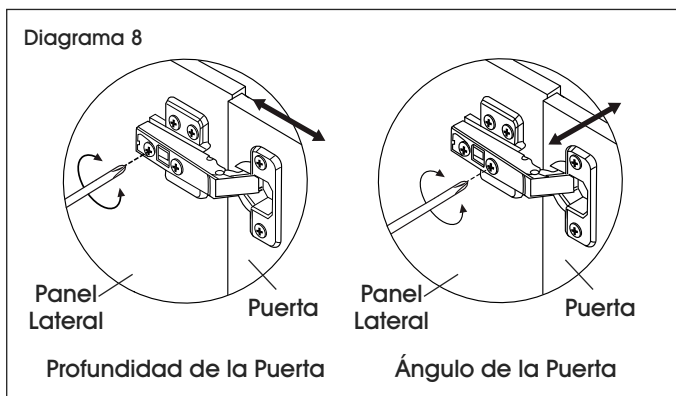

11. La parte superior del gabinete de almacenamiento de la caja H-10295 no se utilizará y se puede desechar. Deje el gabinete de almacenamiento ensamblado a un lado.



Si ensambla la credenza de doble gabinete H-10306, repita el ensamble del gabinete de almacenamiento para armar el segundo gabinete. Luego proceda al ensamble de la credenza en la página 14.

Si ensambla el archivero lateral y el gabinete de credenza H-10307 o la credenza con archivero doble lateral H-11625, abra el H-10303 y siga el ensamble del archivero lateral siguiente.

ENSAMBLE DEL ARCHIVERO LATERAL

1. Retire el asa (B) instalada por dentro de los cajones y use los mismos pernos (M4 x 34 mm) para fijarla al frente del cajón. Repita la operación en todas las asas. (Vea Diagrama 9)

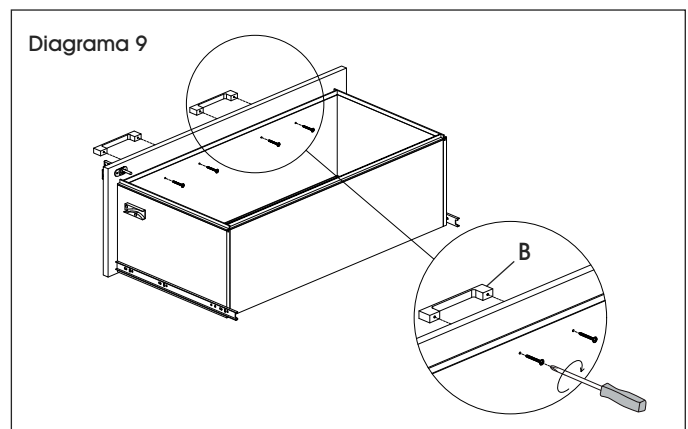

2. Retire el cajón superior presionando las pestañas de plástico en los deslizadores de los cajones y jalando. (Vea Diagrama 10)

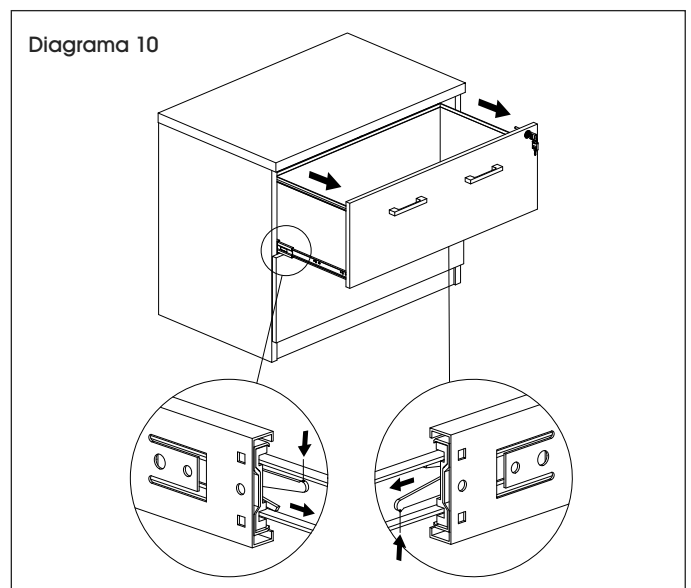

CONTINUACIÓN DEL ENSAMBLE

3. Retire el panel superior (1) quitando ocho pernos M6 x 30 mm (C) utilizando un desarmador de cruz. El panel superior no se utilizará y se puede desechar. Deje el archivero lateral ensamblado a un lado. (Vea Diagrama 11)

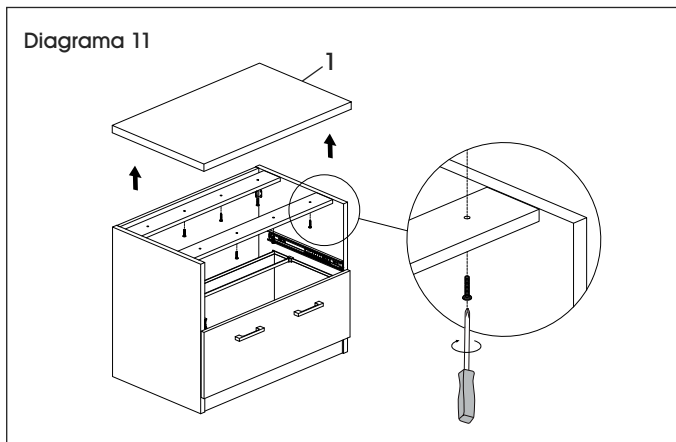

2. Alinee dos soportes planos (Q) con los orificios debajo de los gabinetes. Inserte cuatro tapas niveladoras (A) y apriete para conectar el archivero lateral y el gabinete de almacenamiento. (Vea Diagrama 12)

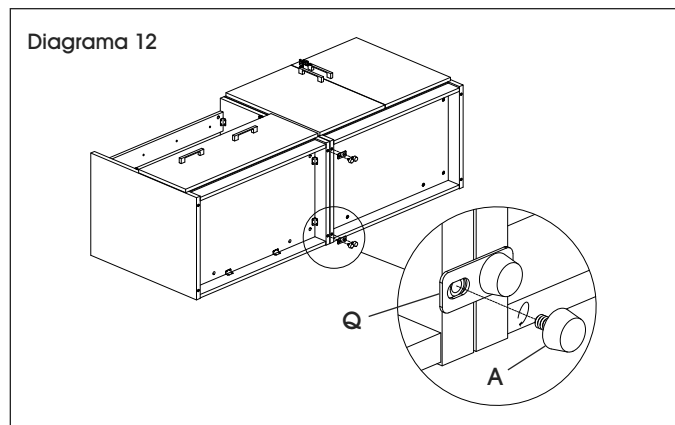

ALTO ¡ALTO! Si ensambla la credenza de archivero doble lateral H-11625, repita el ensamble para armar el segundo archivero lateral. Proceda con el ensamble de la credenza.

ENSAMBLE DE LA CREDENZA

ALTO ¡ALTO! Abra la caja del H-10308 para ensamblar la credenza en los pasos 1-7.

NOTA: Si ensambla la credenza de gabinete doble H-10306 o la credenza con archivero lateral doble H-11625, siga las mismas instrucciones para los pasos 1-6. Los diagramas muestran solo un archivero lateral y la credenza con gabinete.

NOTA: Posicione los gabinetes cerca de la ubicación deseada. Es difícil mover la credenza cuando está completamente ensamblada.

1. Con ayuda de otra persona, coloque los archiveros con cuidado en su parte posterior.

NOTA: Si ensambla el archivero lateral H-10307 y gabinete de credenza, los gabinetes se pueden configurar en cualquier lado. Los diagramas muestran el archivero lateral a la izquierda y el gabinete para almacenamiento a la derecha.

3. Posicione las patas de acero (2) en los lados de los gabinetes. Alinee los soportes planos (Q) en la parte inferior de los gabinetes y la pata de acero. Inserte ocho tapas niveladoras (A) a través de los soportes y apriete para conectar el archivero lateral y el gabinete de almacenamiento. Entre tres personas, levanten los gabinetes con cuidado. (Vea Diagrama 13)

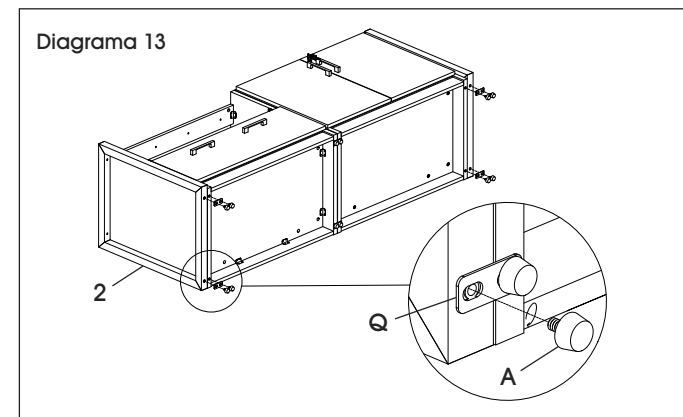

CONTINUACIÓN DEL ENSAMBLE

4. Si ensambla el H-10306 o H-10307, alinee los orificios del soporte en L (F) con los orificios preperforados del panel superior de la credenza (1) en el lado del gabinete para almacenamiento. Inserte dos tornillos M3 x 16 mm (F) y fíjelos utilizando un desarmador de cruz o taladro. Alinee los orificios del tapón para puerta (K) con los orificios preperforados en el panel superior y golpéelo ligeramente con un mazo de caucho para insertarlo. (Vea Diagrama 14)

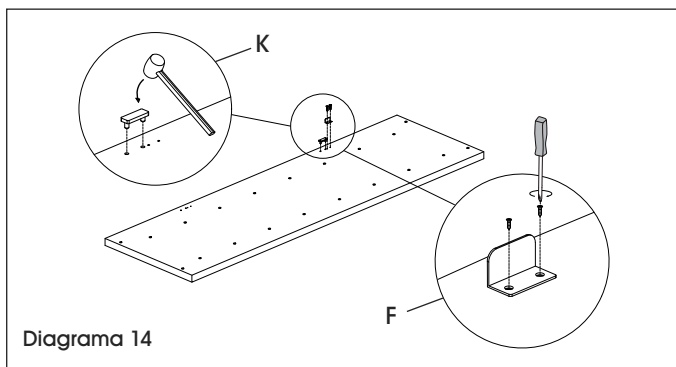

5. Fije el panel superior a las patas del armazón utilizando cuatro pernos M6 x 55 mm (P). (Vea Diagrama 15)

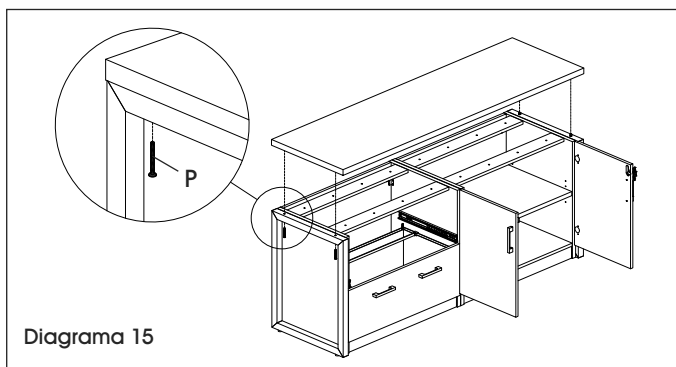

6. Fije el panel superior a las vigas de soporte de los gabinetes utilizando 16 pernos M6 x 30 mm (C). (Vea Diagrama 16)

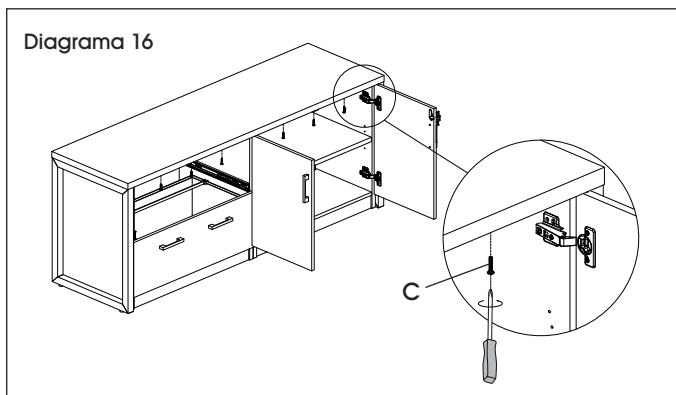

- ALTO** ¡ALTO! Siga los pasos 7-9 si ensambla el archivero lateral H-10307 y la credenza con gabinete o la credenza con archivero lateral doble H-11625. De lo contrario, proceda al paso 10.

7. Vuelva a fijar el cajón superior del archivero lateral insertando las pestañas de plástico en los deslizadores del cajón. (Vea Diagrama 17)

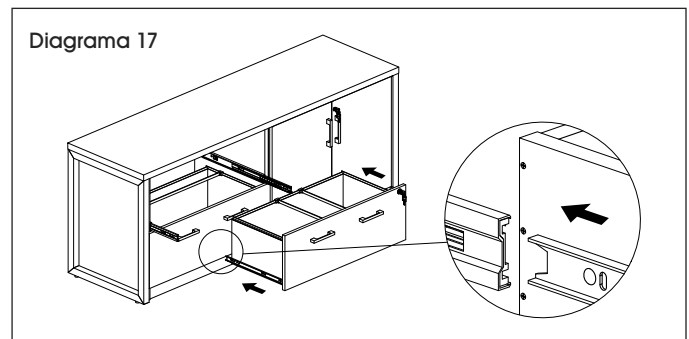

8. Para colgar archivos de lado a lado, fije un clip para carpetas (L) a cada lado del cajón e inserte una barra larga de metal (M). (Vea Diagrama 18)

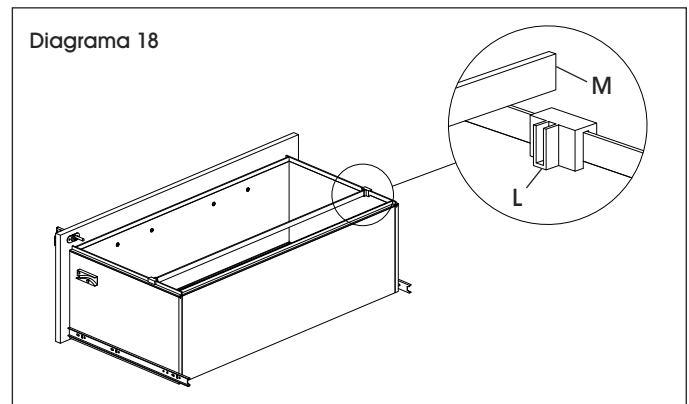

9. Para colgar archivos de frente hacia atrás, fije dos clips para carpeta (L) al lado posterior del cajón y dos al lado frontal del cajón e inserte dos barras cortas de metal (N). (Vea Diagrama 19)

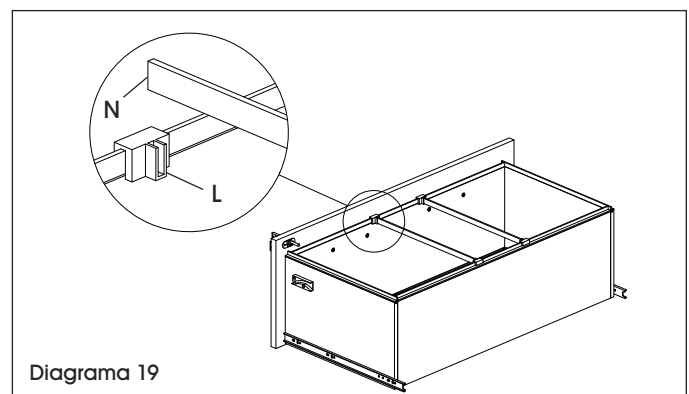

CONTINUACIÓN DEL ENSAMBLE

10. Fije un soporte del anclaje (R) para pared a la parte posterior del archivero superior con dos tornillos M4 x 20 mm. Marque los orificios en la pared donde se colocarán los anclajes de plástico. Taladre los orificios utilizando la broca de 5/16". Instale el soporte opuesto del anclaje en la pared con dos tornillos M4 x 40 mm y dos anclajes de plástico. Apriete el cincho para evitar que se vuelque. Repita la operación para el lado opuesto de la credenza. (Vea Diagrama 20)

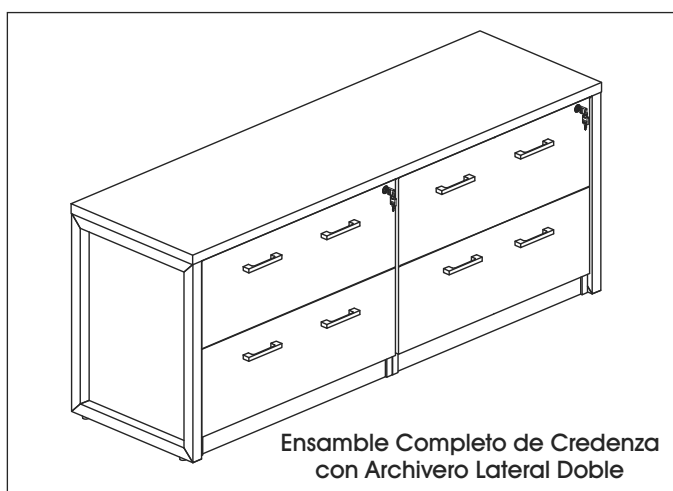
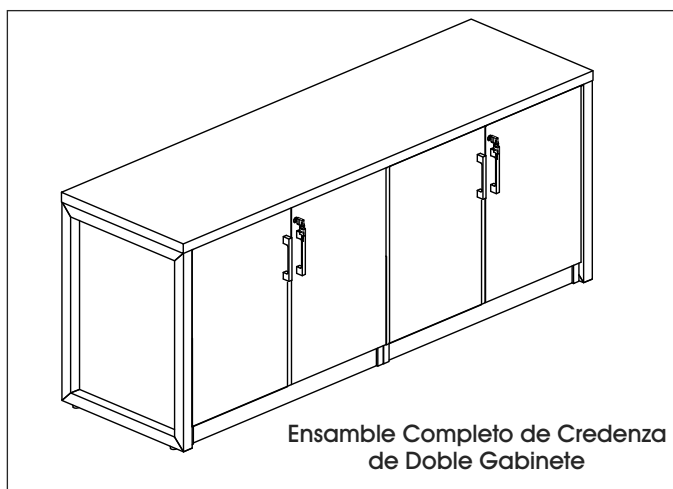
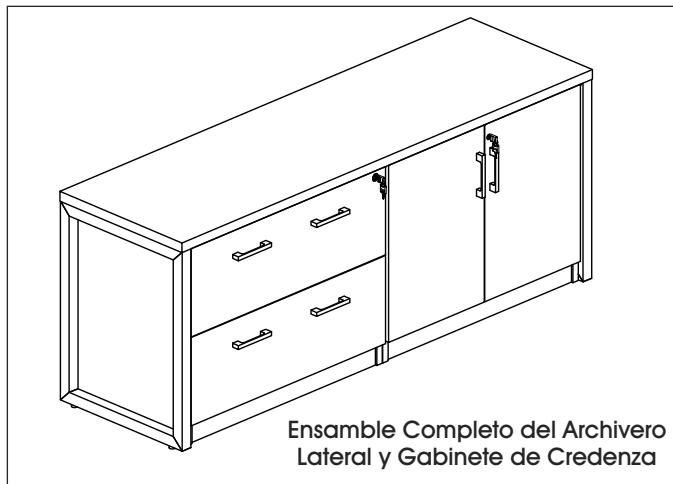
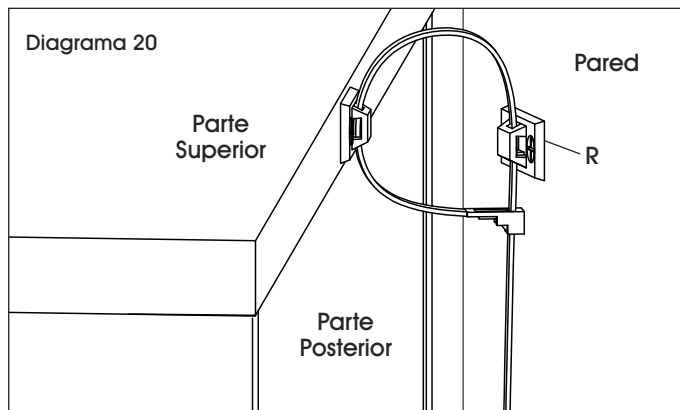

ULINE

800-295-5510
uline.mx

ULINEH-10306, H-10307
H-116251 800 295-5510
uline.ca**COLLECTION METRO**

BAHUT DE RANGEMENT

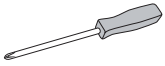
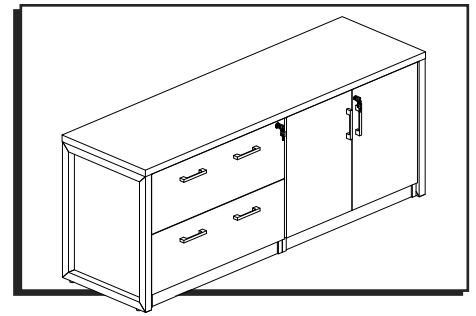
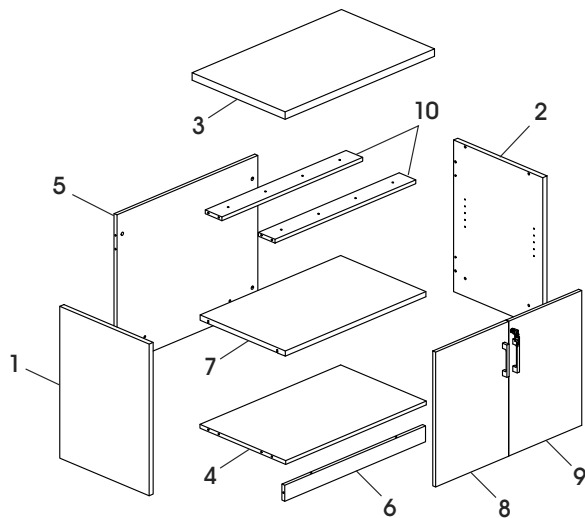
OUTILS REQUISTournevis
cruziformeMaillet en
caoutchoucPerceuse
(optionnel)Mèche de perceuse
de 5/16 po
(optionnel)Clé Allen
(optionnel)Montage à trois personnes
recommandé**PIÈCES DE L'ARMOIRE DE RANGEMENT****PIÈCES DE L'ARMOIRE DE RANGEMENT**

#	DESCRIPTION	QTÉ
1	Panneau latéral gauche	1
2	Panneau latéral droit	1
3	Panneau supérieur	1
4	Panneau inférieur	1
5	Panneau arrière	1
6	Panneau de base	1
7	Tablette	1
8	Porte gauche	1
9	Porte droite	1
10	Barre de support	2

A



Patin réglable x 4

B

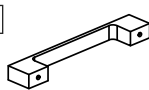

Poignée en métal x 2

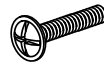

Boulon M4 x 22 mm x 4

C

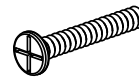

Boulon M6 x 30 mm x 8

D

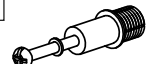

Goujon d'excentrique x 17

F



Support en L x 1



Support en S x 1



Vis M3 x 16 mm x 4



Serrure x 1



Vis M3,5 x 14 mm x 2

E



Excentrique x 17

G



Cheville x 12

H



Cheville de tablette x 4

I



Cache pour excentrique x 17

K

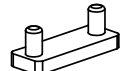

Bouchon de porte x 1

J

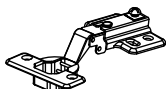

Charnière x 4



Boulon M4 x 10 mm x 8



Vis M4 x 14 mm x 16

R

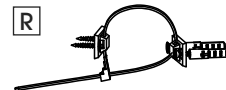
Matériel d'ancrage
mural x 1

PIÈCES DU CLASSEUR LATÉRAL

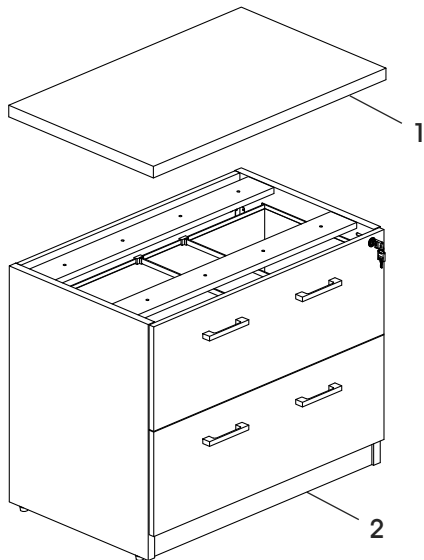

PIÈCES DU CLASSEUR LATÉRAL

#	DESCRIPTION	QTÉ
1	Panneau supérieur	1
2	Armoire	1

A



Patin réglable x 4

B

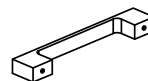

Poignée en métal x 2

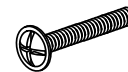

Boulon M4 x 34 mm x 8

C



Boulon M6 x 30 mm x 8

L



Attache pour dossier x 8

M

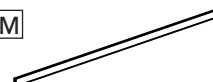

Barre longue en métal x 2

N

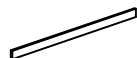

Barre courte en métal x 4

O



Clé (jeu de 2) x 1

R



Matériel d'ancrage mural x 1

PIÈCES DU BAHUT

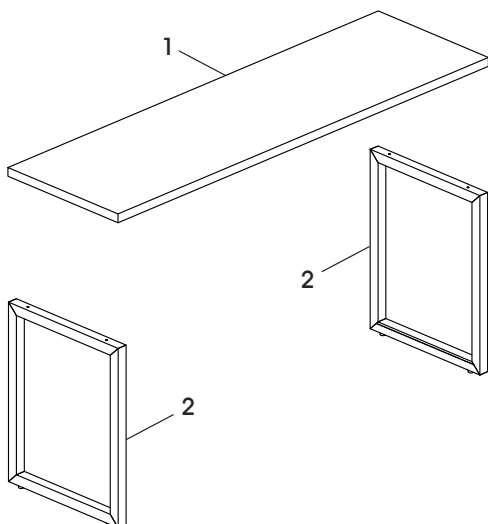

PIÈCES DU BAHUT

#	DESCRIPTION	QTÉ
1	Panneau supérieur du bahut	1
2	Pied en acier	2

A



Patin réglable x 4

P

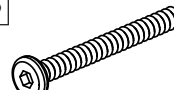

Boulon M6 x 55 mm x 4

Q



Support plat x 6

ARMOIRE DE RANGEMENT



Si vous assemblez le H-10306 ou le H-10307, ouvrez d'abord le carton du H-10295 pour monter l'armoire de rangement (étapes 1 à 11). Si vous assemblez le H-11625, ouvrez le carton du H-10303 et passez au montage du classeur latéral à la page 21.



IMPORTANT! Tournez l'excentrique de 1/4 de tour vers la droite pour le verrouiller.

IMPORTANT! UTILISATION DES EXCENTRIQUES

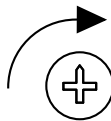

1/4 DE TOUR VERS LA DROITE POUR VERROUILLER

Assurez-vous d'abord que la flèche pointe vers le bord du panneau avant de l'insérer dans le trou du panneau.



IMPORTANT! Les goujons d'excentrique doivent être serrés après insertion dans le panneau. Pour serrer les goujons d'excentrique, saisissez la partie inférieure du goujon et serrez avec un tournevis cruciforme.

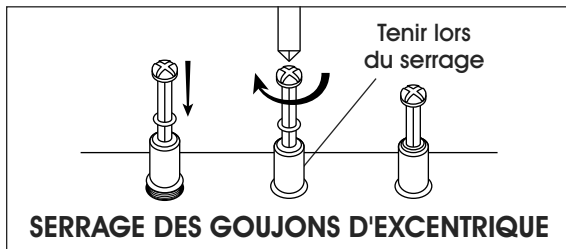

REMARQUE : Utilisez le tournevis cruciforme pour serrer les excentriques, les goujons d'excentrique et les vis.



REMARQUE : Une fois les excentriques serrés, les caches pour excentrique (I) peuvent être installés pour donner un aspect fini.

1. Installez un goujon d'excentrique (D) dans le panneau inférieur (4). Insérez un excentrique (E) dans le trou correspondant du panneau de base (6). Assemblez les panneaux inférieur et de base et serrez l'excentrique. (Voir Figure 1)

Figure 1

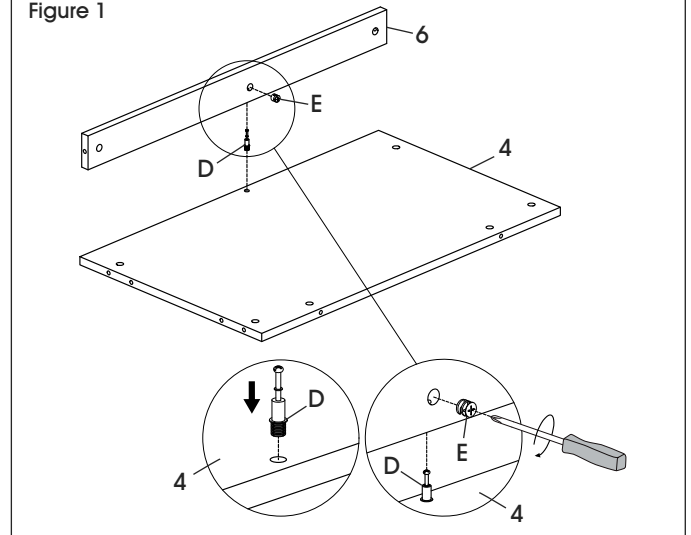

2. Installez deux goujons d'excentrique (D) et deux chevilles (G) dans le panneau arrière (5). Insérez deux excentriques (E) dans les trous correspondants du panneau inférieur (4). Assemblez les panneaux arrière et inférieur et serrez les excentriques. (Voir Figure 2)

Figure 2

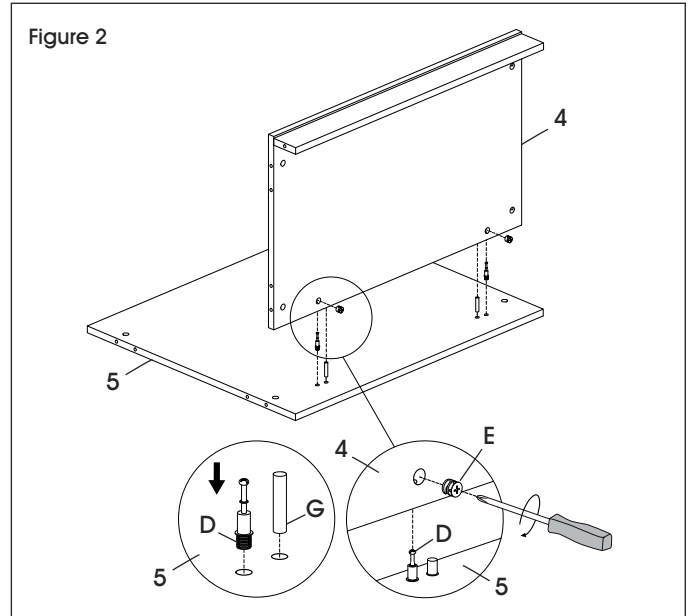

MONTAGE SUITE

3. Installez sept goujons d'excentrique (D) et six chevilles (G) dans le panneau latéral gauche (1). Insérez sept excentriques (E) dans les trous correspondants du panneau arrière (5), du panneau inférieur (4), du panneau de base (6) et des barres de support supérieures (10). Assemblez le panneau latéral gauche avec les panneaux arrière, inférieur et de base, ainsi que les barres de support supérieures, puis serrez les excentriques. Répétez l'opération pour le panneau latéral droit (2). (Voir Figure 3)

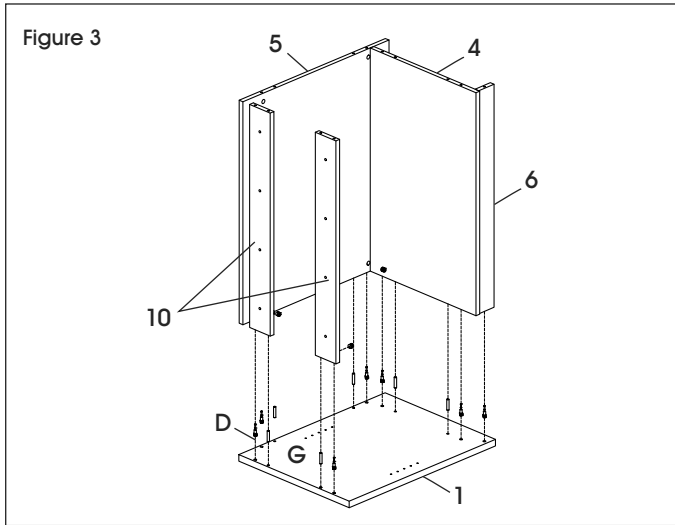

4. Placez l'armoire à la verticale. Insérez quatre chevilles de tablette (H) à l'emplacement voulu dans les trous des panneaux latéraux (1 et 2). Placez la tablette (7) dans l'armoire et assurez-vous que les supports de tablette sont correctement positionnés sur les chevilles de tablette. Serrez les supports de tablette situés sous les tablettes pour bien les ajuster. (Voir Figure 4)

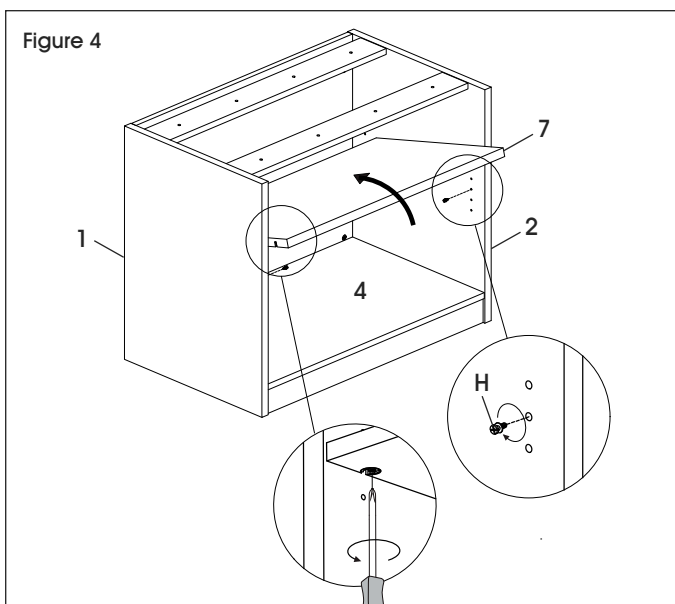

5. Placez les portes gauche (8) et droite (9) sur une surface lisse qui ne marque pas pour éviter les rayures. Alignez les trous de charnière (J) sur les trous prépercés des panneaux de porte. Insérez deux boulons M4 x 10 mm (J), puis serrez. Répétez l'opération pour les trois autres charnières. (Voir Figure 5)
6. Fixez les poignées (B) sur la partie extérieure des portes avec quatre boulons M4 x 22 mm (B). (Voir Figure 5)
7. Alignez les trous du support en S (F) sur les trous prépercés en haut de la porte gauche (8). Insérez deux vis M3 x 16 mm (F), puis serrez. (Voir Figure 5)
8. Alignez les trous de la serrure (F) sur les trous prépercés de la porte droite (9). Insérez deux vis M3,5 x 14 mm (F), puis serrez. (Voir Figures 5 à 6)

 **REMARQUE :** Référez-vous à la Figure 6 pour l'orientation correcte de la serrure.

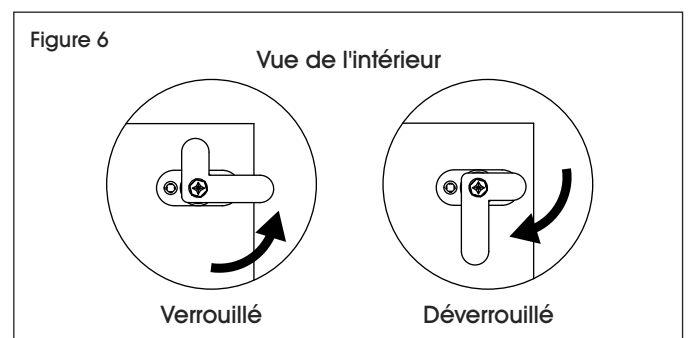
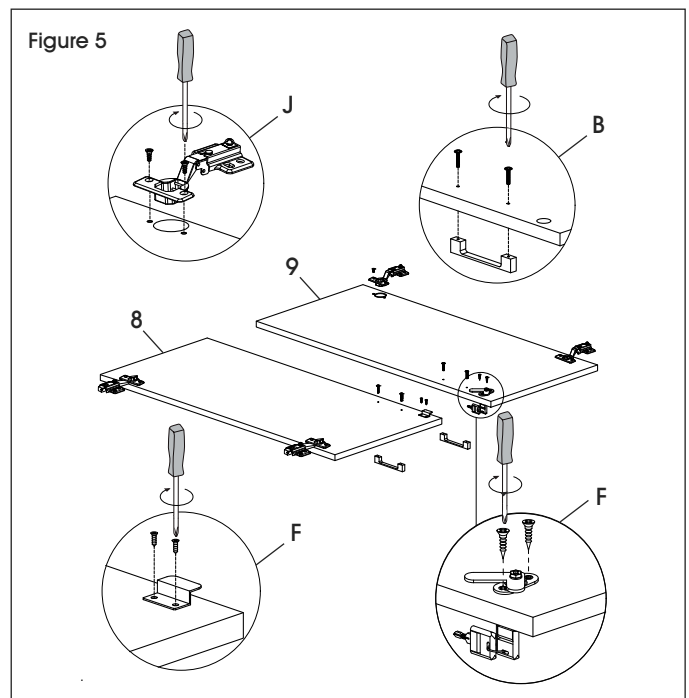

MONTAGE SUITE

9. À deux, tenez la porte au niveau du panneau latéral. Fixez la charnière (J) à l'intérieur des panneaux latéraux avec quatre vis M4 x 14 mm (J). Répétez l'opération pour les trois autres charnières. (Voir Figure 7)

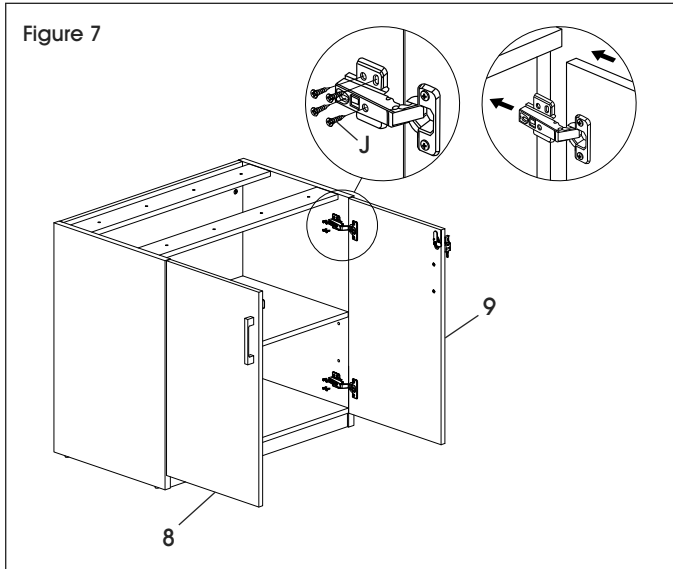

10. Une fois les portes fixées, il peut être nécessaire d'ajuster chaque charnière pour aligner les portes. Pour régler la profondeur des portes, serrez ou desserrez la vis arrière de la charnière. Pour régler l'angle des portes, serrez ou desserrez la vis centrale de la charnière. (Voir Figure 8)

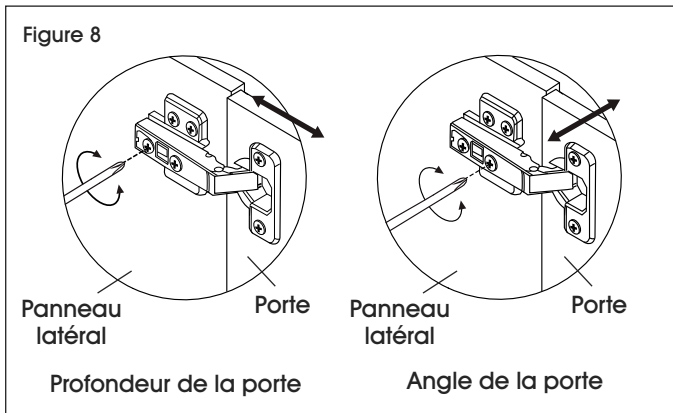

11. La surface de l'armoire de rangement se trouvant dans le carton du H-10295 ne sera pas utilisée et peut être mise au rebut. Placez l'armoire de rangement assemblée de côté.



ARRÊT! Si vous montez le bahut avec armoire double H-10306, répétez les étapes pour le montage de la seconde armoire. Passez ensuite au montage du bahut à la page 22.

Si vous montez le bahut avec classeur latéral et armoire H-10307, ou le bahut avec classeur latéral double H-11625, ouvrez le carton du H-10303 et suivez les étapes de montage du classeur latéral ci-dessous.

MONTAGE DU CLASSEUR LATÉRAL

1. Retirez la poignée (B) située à l'intérieur du tiroir et fixez-la à l'extérieur avec les mêmes boulons (M4 x 34 mm). Répétez l'opération pour toutes les autres poignées. (Voir Figure 9)

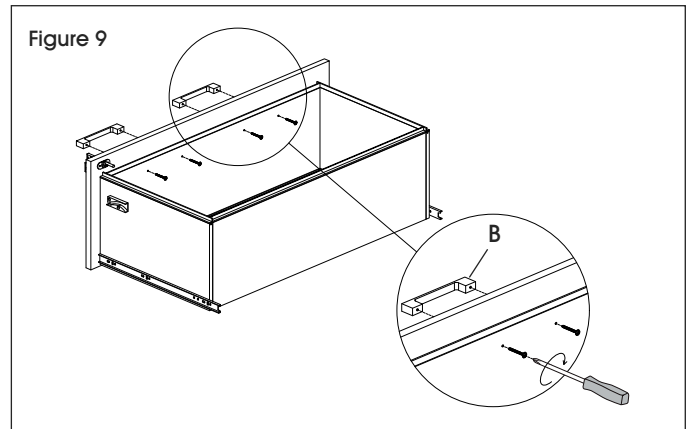

2. Pour retirer le tiroir supérieur, appuyez sur les languettes en plastique des glissières, puis tirez le

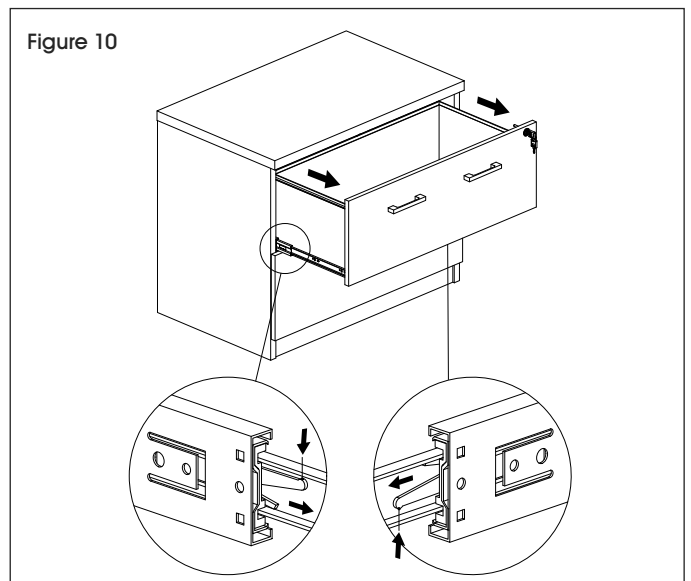

tiroir vers l'extérieur. (Voir Figure 10)

- À deux, tenez la porte au niveau du panneau. Retirez le panneau supérieur (1) en dévissant les huit boulons M6 x 30 mm (C) avec un tournevis cruciforme. Gardez les boulons pour le montage du cadre supérieur du bahut. Le panneau supérieur ne sera pas utilisé et peut être mis au rebut. Placez le classeur latéral assemblé de côté. (Voir Figure 11)

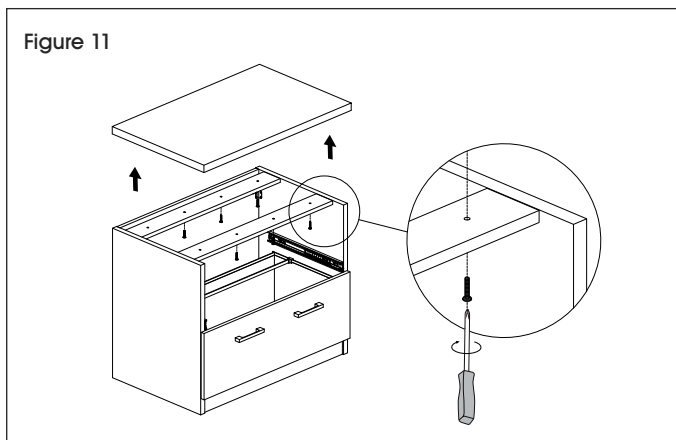

ARRÊT! Si vous montez le bahut avec classeur latéral double H-11625, répétez les étapes de montage du classeur latéral pour le second classeur. Passez ensuite au montage du bahut.

MONTAGE DU BAHUT

ARRÊT! Ouvrez le carton du H-10308 pour monter le bahut (étapes 1 à 7).

REMARQUE : Si vous montez le bahut avec armoire double H-10306 ou le bahut avec classeur latéral double H-11625, vous devez suivre les mêmes étapes 1 à 6. Les illustrations montrent uniquement le montage du bahut avec classeur latéral et armoire.

REMARQUE : Placez les armoires près de l'emplacement voulu. Le bahut est difficile à déplacer lorsqu'il est complètement monté.

- À deux, posez avec précaution les armoires sur le dos.

REMARQUE : Si vous montez le H-10307, bahut avec classeur latéral et armoire, les armoires peuvent être placées dans n'importe quel ordre. Le montage illustré montre le classeur latéral placé à gauche et l'armoire à droite.

- Alignez deux supports plats (Q) sur les trous prépercés situés sous les armoires. Insérez quatre patins réglables (A) à travers les supports et serrez-les pour relier le classeur latéral à l'armoire. (Voir Figure 12)

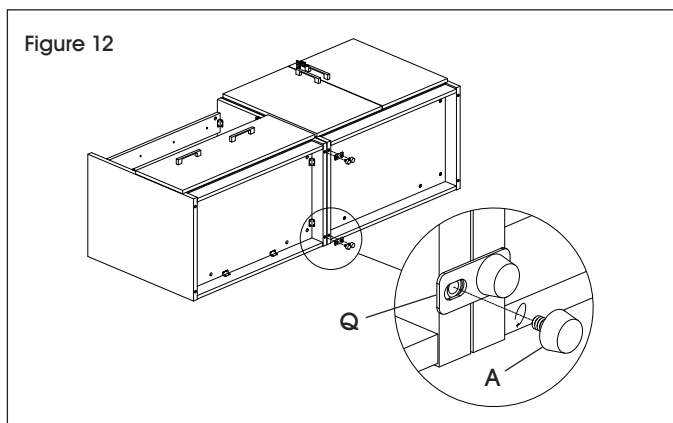

- Placez les pieds en acier (2) sur les côtés des armoires. Alignez les supports plats (Q) sur la partie inférieure des armoires et sur le pied en acier. Insérez huit patins réglables (A) à travers les supports et serrez-les pour relier les armoires aux pieds en acier. À trois, placez avec précaution les armoires à la verticale. (Voir Figure 13)

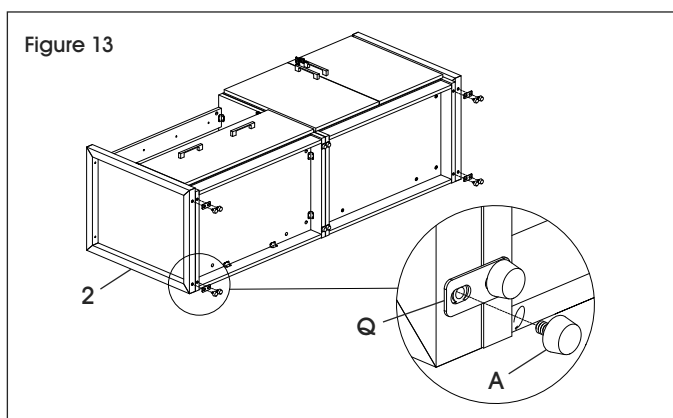

MONTAGE SUITE

4. Si vous assemblez les modèles H-10306 ou H-10307, alignez les trous du support en L (F) sur les trous prépercés du panneau supérieur du bahut (1) situés sur le côté de l'armoire de rangement. Insérez deux vis M3 x 16 mm (F) et serrez-les avec le tournevis cruciforme ou la perceuse. Alignez les trous du bouchon de porte (K) sur les trous prépercés du panneau supérieur et insérez-le avec précaution avec un maillet en caoutchouc. Répétez la procédure du côté opposé si vous montez le H-10306, bahut avec armoire double. (Voir Figure 14)

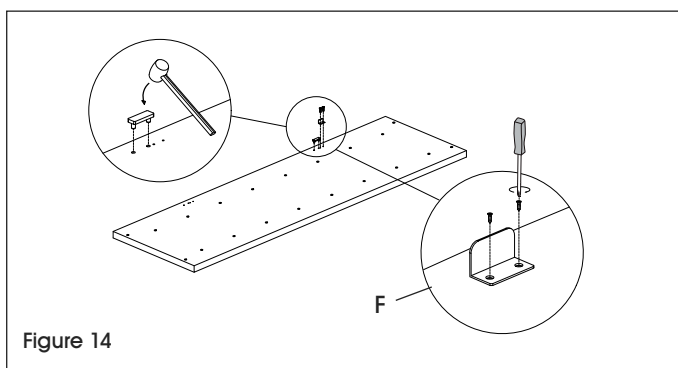

ARRÊT! Vous devez uniquement suivre les étapes 7 à 9 si vous assemblez le bahut avec classeur latéral et armoire H-10307 ou le bahut avec classeur latéral double H-11625. Si ce n'est pas le cas, passez à l'étape 10.

7. Remplacez le tiroir supérieur du classeur latéral en insérant les languettes en plastique dans les glissières du tiroir. (Voir Figure 17)

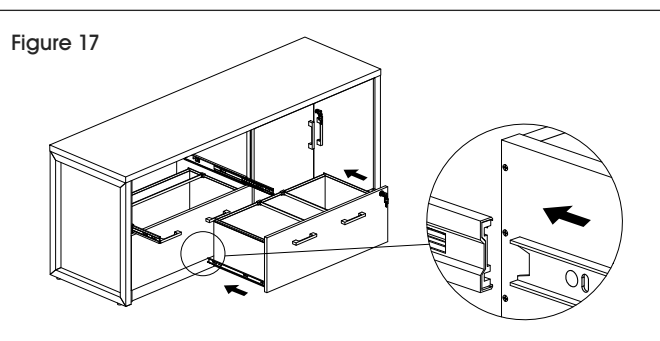

8. Pour suspendre les dossiers latéralement, fixez une attache pour dossier (L) sur chaque côté du tiroir et insérez une barre longue en métal (M). (Voir Figure 18)

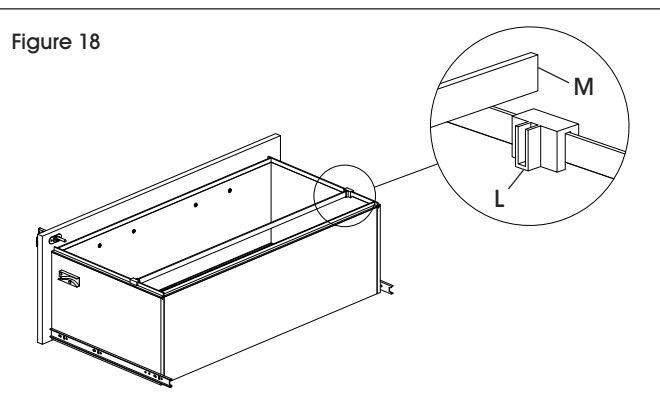

5. Fixez le panneau supérieur aux pieds du cadre avec quatre boulons M6 x 55 mm (P). (Voir Figure 15)

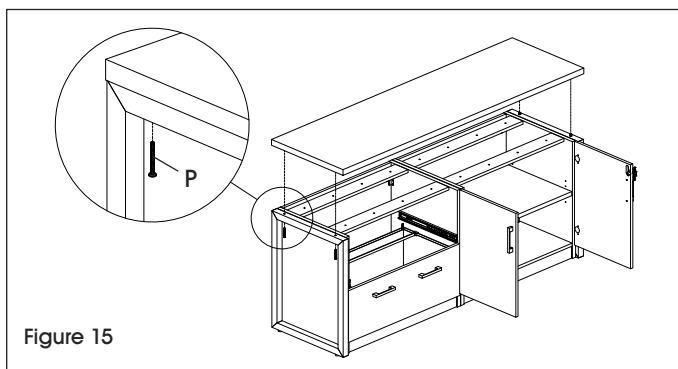

9. Pour suspendre les dossiers transversalement, fixez deux attaches pour dossier (L) à l'arrière du tiroir et deux à l'avant, puis insérez deux barres courtes en métal (N). (Voir Figure 19)

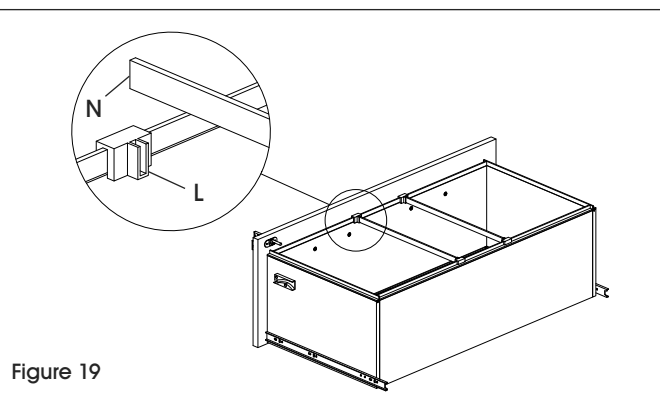

6. Fixez le panneau supérieur du bahut aux barres de support des armoires avec 16 boulons M6 x 30 mm (C). (Voir Figure 16)

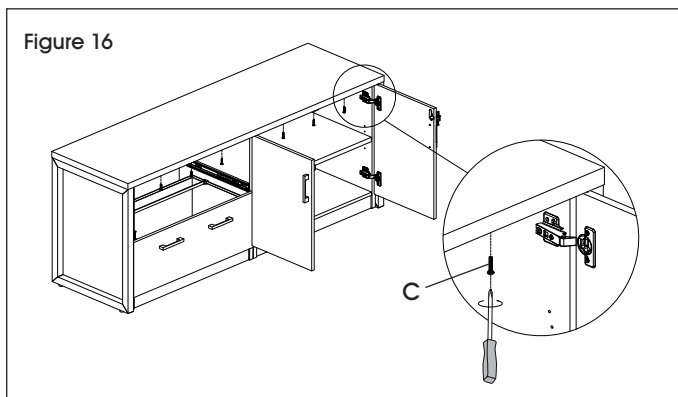

MONTAGE SUITE

10. Fixez un support d'ancrage mural (R) sur la partie supérieure arrière du classeur avec deux vis M4 x 20 mm. Marquez l'emplacement des trous sur le mur pour les ancrages en plastique. Percez les trous en utilisant la mèche de perceuse de 5/16 po. Fixez au mur le support d'ancrage mural opposé avec deux vis M4 x 40 mm et deux ancrages en plastique. Serrez l'attache-câble pour empêcher tout basculement. Répétez l'opération de l'autre côté du bahut. (Voir Figure 20)

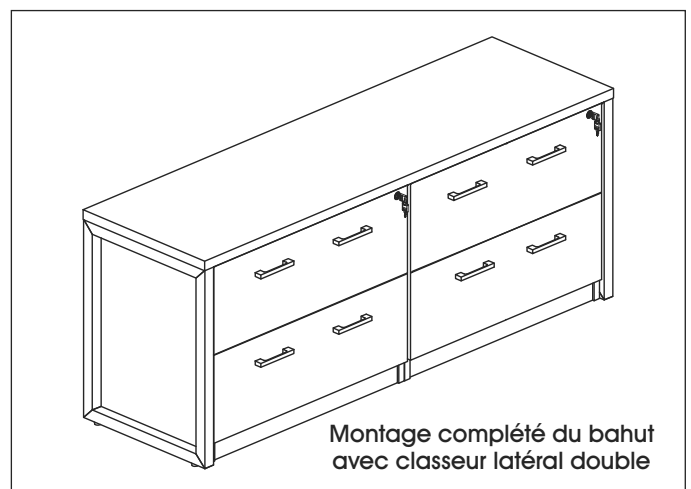
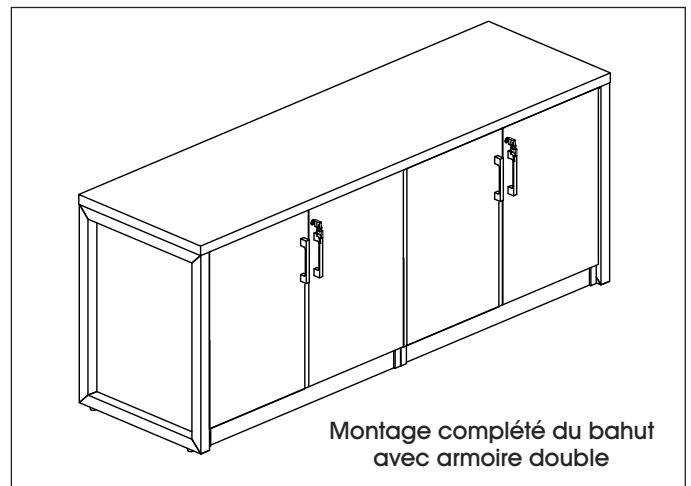
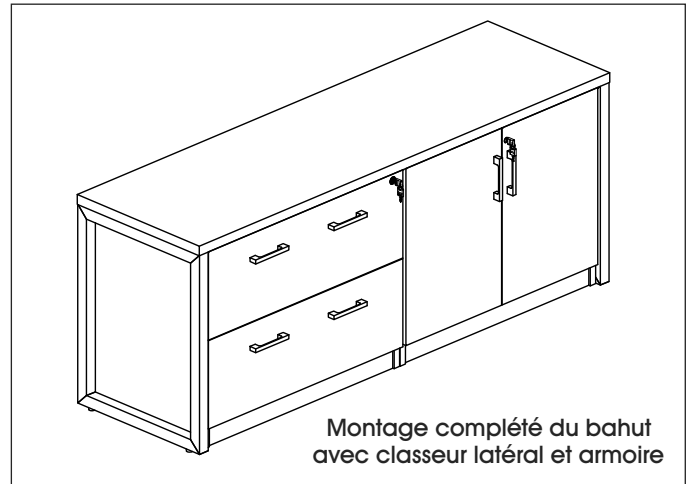
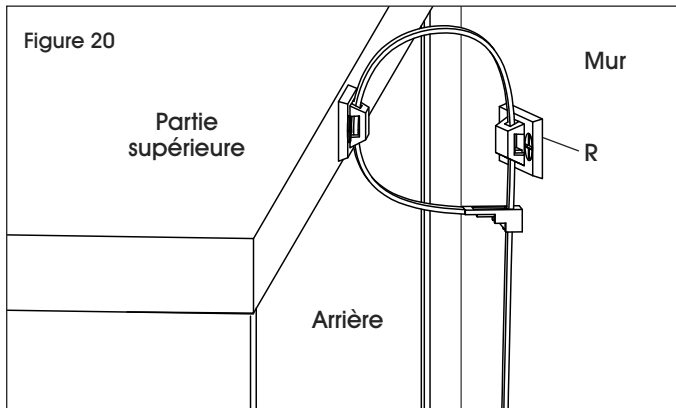

ULINE

1 800 295-5510
uline.ca