

ULINE H-10336, H-10337 H-10338 FREESTANDING MAIL SORTERS

1-800-295-5510
uline.com

TOOLS NEEDED



Phillips Screwdriver



Flathead Screwdriver
(optional)



Drill
(optional)



10 mm Wrench



Rubber Mallet



5/16" Drill Bit
(optional)



Two Person Assembly
Recommended

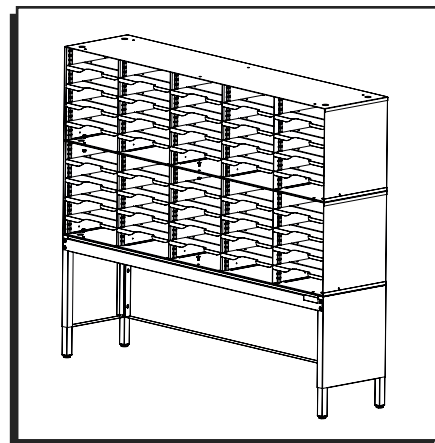

PARTS FOR BASE

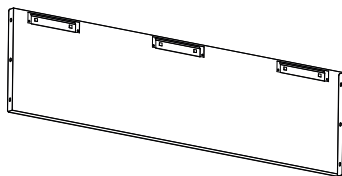

Back Panel x 1



Top Panel x 1



Front Support Channel x 1



Left Side Panel x 1

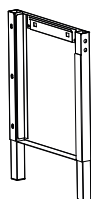

Right Side Panel x 1

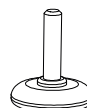

Adjustable Leveling
Foot x 4



M6 x 12 mm Bolt x 10

BASE ASSEMBLY

1. Insert adjustable leveling feet into ends of side panel legs. (See Figure 1)

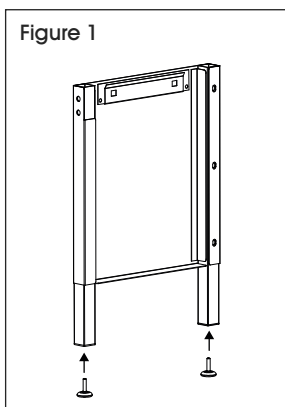

2. Place top panel upside down. Attach right side panel by inserting locking tabs into matching square holes on top panel. Gently tap with a rubber mallet to fully engage tabs. Repeat for left side panel. (See Figure 2)



NOTE: Locking tabs can be adjusted with a flathead screwdriver for easy assembly.



NOTE: Three holes on inside of the legs should be in the rear by the longer flange.

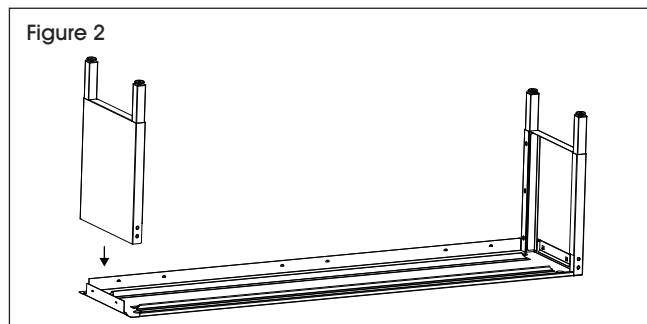

BASE ASSEMBLY CONTINUED

Figure 3

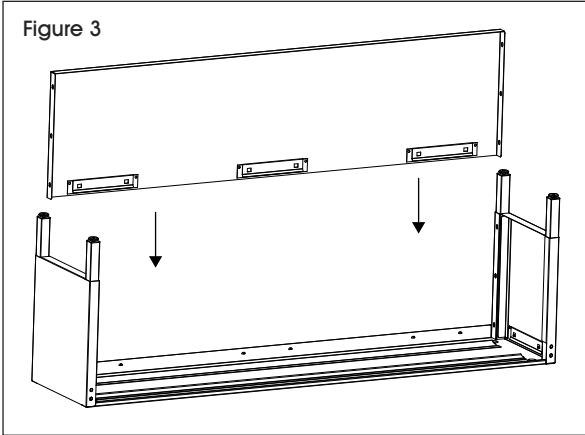

3. Place back panel inside side panels and top panel by inserting locking tabs into matching square holes on top panel. (See Figure 3)

Figure 4

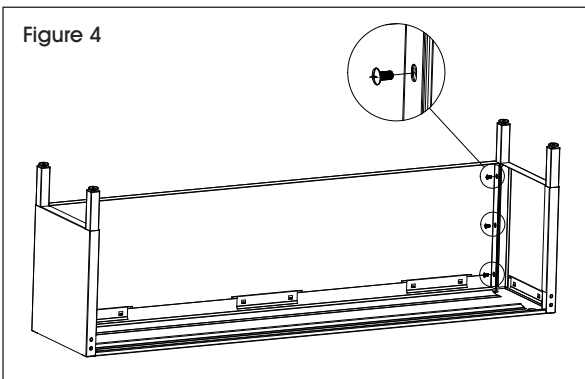

4. Insert six M6 x 12 mm bolts to fasten the back panel to side panels and top panel using a Phillips screwdriver. (See Figure 4)

Figure 5

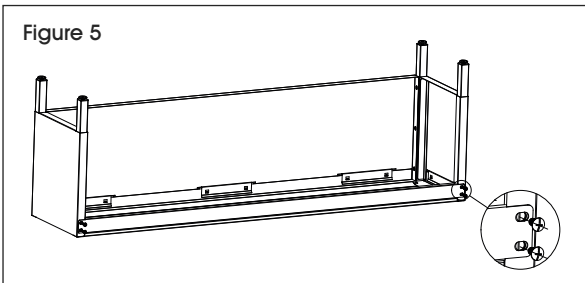

5. Attach front support channel to side panels by inserting four M6 x 12 mm bolts using a Phillips screwdriver. (See Figure 5)

PARTS FOR MAIL SORTER

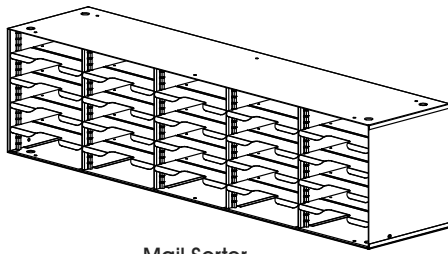

Mail Sorter



M6 x 10 mm Bolt



M6 Nut

	NUMBER OF MAIL SORTERS	M6 x 10 mm BOLT	M6 NUT
H-10336	2	12	12
H-10337	3	18	18
H-10338	4	24	24

MAIL SORTER ASSEMBLY

- Stack one mail sorter on top of base. Fasten mail sorter to base using six M6 x 10 mm bolts and six M6 nuts using a Phillips screwdriver and 10 mm wrench. Holes are located in the front and rear of the sorter on the far left, center and right columns. (See Figure 6)



NOTE: Mail sorter shelves can be removed to provide more space when tightening bolts and nuts.

- Stack second mail sorter on top of attached mail sorter. Fasten mail sorter to attached mail sorter using six M6 x 10 mm bolts and six M6 nuts using a Phillips screwdriver and 10 mm wrench. If assembling a 75-slot or 100-slot unit, repeat for remaining mail sorters. (See Figure 6)

COMPLETED ASSEMBLY

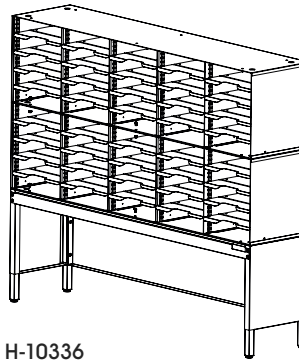

H-10336

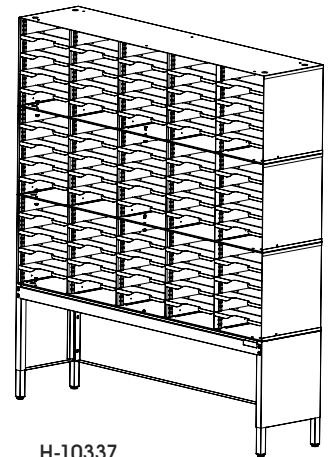

H-10337

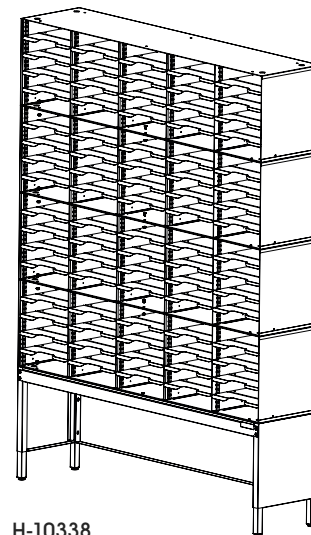

H-10338

Figure 6

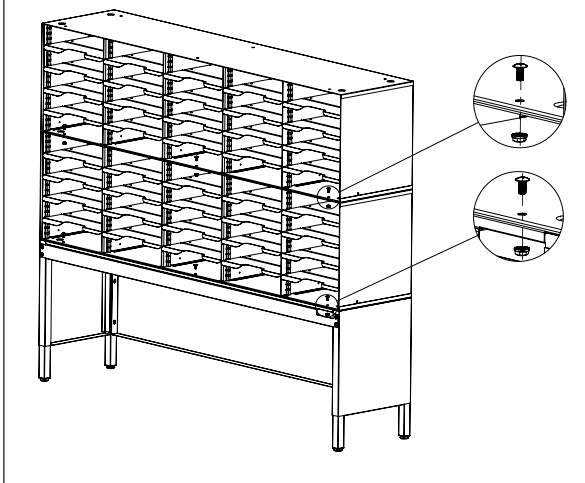

CAUTION! Do not stack more than four mail sorters.

PARTS FOR WALL ANCHOR KIT

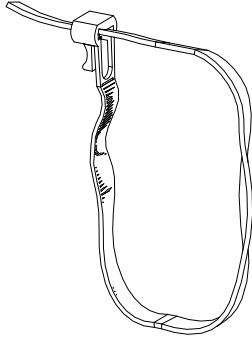

Cable Tie x 2

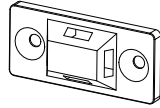

Wall Bracket x 2



Metal Bracket x 2

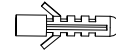

Plastic Anchor x 4



ST3.5 x 38 mm Screw x 4



M6 x 12 mm Bolt x 2



M6 Nut x 2

WALL ANCHOR KIT ASSEMBLY

Figure 7

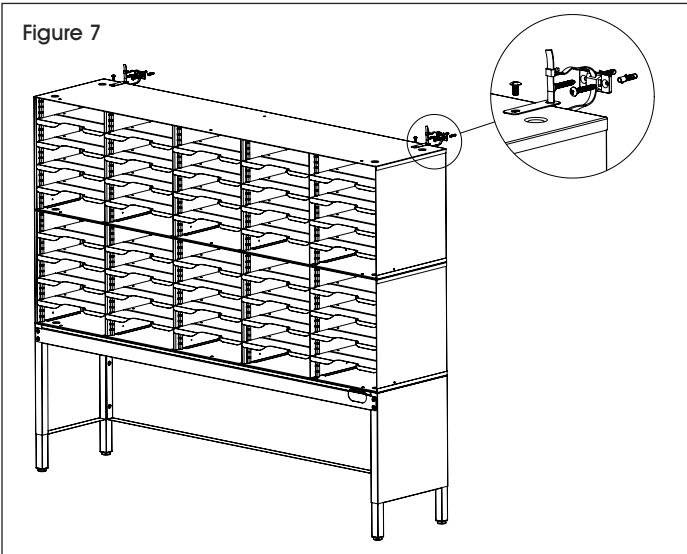

1. Mark holes on wall where plastic anchors will be located. Drill holes using 5/16" drill bit.
 2. Mount wall bracket to wall with two ST3.5 x 38 mm screws and plastic anchors. (See Figure 7)
 3. Secure metal bracket to top of mail sorter using one M6 nut and one M6 x 12 mm bolt. (See Figure 7)
-  **NOTE:** End with slotted hole should be attached to the mail sorter.
4. Tighten cable tie to prevent tipping. Repeat for other side of mail sorter.

ULINE

1-800-295-5510
uline.com



H-10336, H-10337
H-10338

CLASIFICADORES DE CORREO

800-295-5510
uline.mx

HERRAMIENTAS NECESARIAS



Desarmador de Cruz

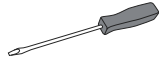

Desarmador Plano (opcional)



Taladro (opcional)



Llave de 10 mm



Mazo de Caucho



Broca de 5/16" (opcional)



Se Recomienda Armar Entre Dos Personas

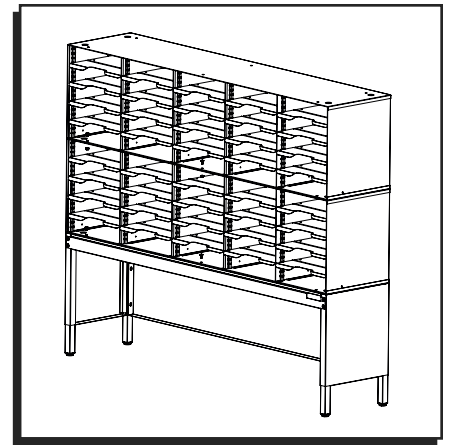

PARTES DE LA BASE

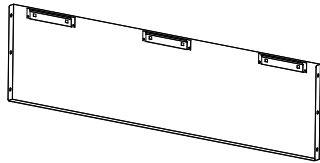

1 Panel Posterior



1 Panel Superior



1 Soporte de Riel Frontal

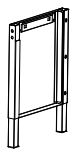

1 Panel Lateral Izquierdo

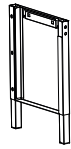

1 Panel Lateral Derecho

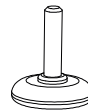

4 Patas Autoniveladoras



10 Pernos M6 x 12 mm

ENSAMBLE DE LA BASE

1. Inserte las patas autoniveladoras en los extremos de las patas del panel lateral. (Vea Diagrama 1)

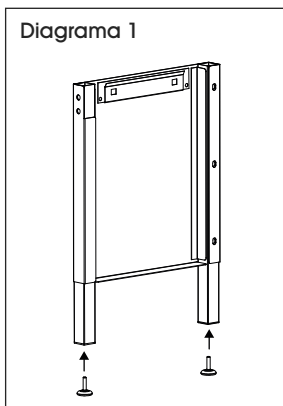

2. Voltee el panel superior. Fije el panel del lado derecho insertando las pestañas en los orificios cuadrados correspondientes al panel superior. Golpee ligeramente con un mazo de caucho para insertar las pestañas por completo. Repita la operación con el panel del lado izquierdo. (Vea Diagrama 2)



NOTA: Las pestañas se pueden ajustar con un desarmador de cabeza plana para facilitar el ensamble.



NOTA: Tres orificios del interior de las patas deben quedar en la parte posterior del lado más largo del reborde.

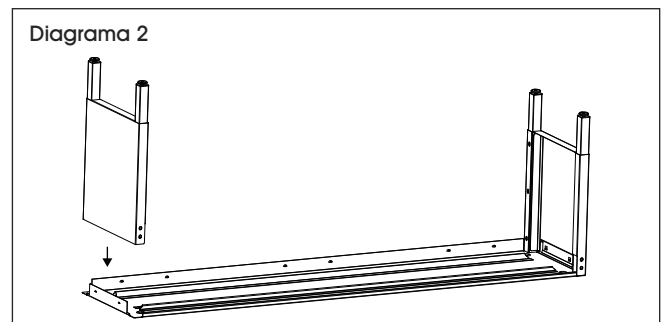

CONTINUACIÓN DEL ENSAMBLE DE LA BASE

Diagrama 3

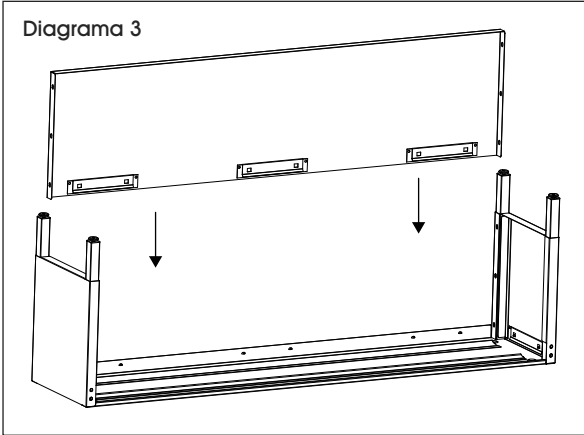

3. Coloque el panel posterior dentro de los paneles laterales insertando las pestañas dentro de los orificios cuadrados correspondientes del panel superior. (Vea Diagrama 3)

Diagrama 4

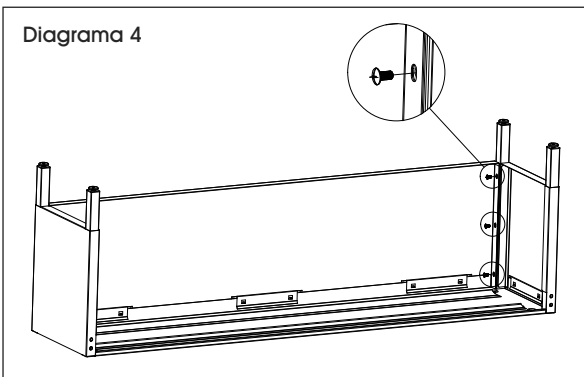

4. Utilice un desarmador de cruz para insertar seis pernos M6 x 12 mm para asegurar el panel posterior a los paneles laterales y el panel superior. (Vea Diagrama 4)

Diagrama 5

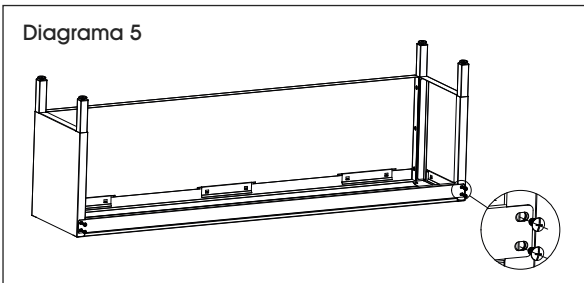

5. Utilice un desarmador de cruz para fijar el riel de soporte frontal a los paneles laterales insertando cuatro pernos M6 x 12 mm. (Vea Diagrama 5)

PARTES PARA EL CLASIFICADOR DE CORREO

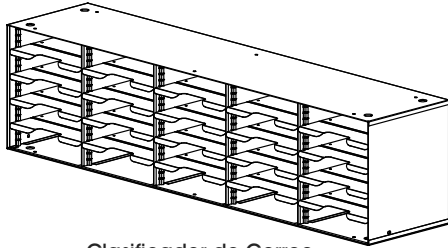

Clasificador de Correo



Perno
M6 x 10 mm



Tuerca M6

	NÚMERO DE CLASIFICADORES DE CORREO	PERNO M6 x 10 mm	TUERCA M6
H-10336	2	12	12
H-10337	3	18	18
H-10338	4	24	24

ENSAMBLE DEL CLASIFICADOR DE CORREO

- Coloque un clasificador de correo en la parte superior de la base. Utilice un desarmador de cruz para fijar el clasificador de correo con seis pernos M6 x 10 mm y seis tuercas M6 y llave de 10 mm. Los orificios están ubicados en la parte frontal y posterior del clasificador en las columnas del extremo izquierdo, centro y extremo derecho. (Vea Diagrama 6)



NOTA: Las repisas del clasificador de correo se pueden retirar para proporcionar mayor espacio al apretar pernos y tuercas.

- Coloque el segundo clasificador de correo en la parte superior del clasificador de correo instalado. Fije el clasificador de correo al clasificador de correo instalado utilizando seis pernos M6 x 10 mm y 6 tuercas M6 utilizando un desarmador de cruz y una llave de 10 mm. Si va a ensamblar una unidad de 75 o 100 compartimentos repita la operación con los clasificadores restantes. (Vea Diagrama 6)

ENSAMBLE TERMINADO

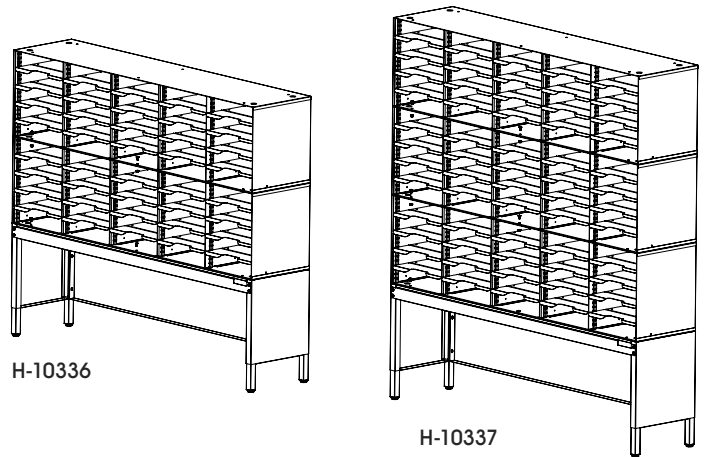

H-10336

H-10337



Diagrama 6



H-10338

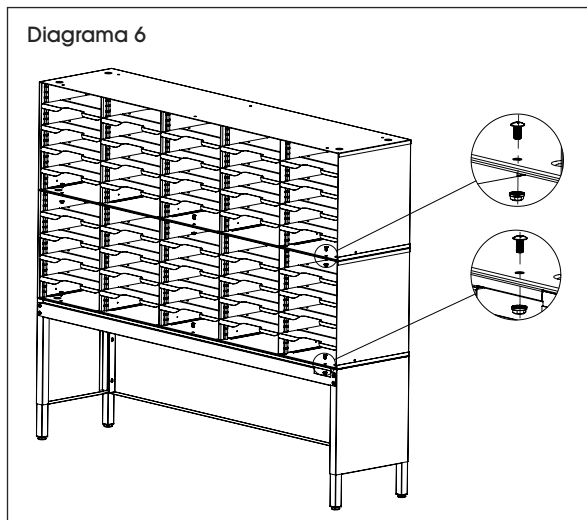
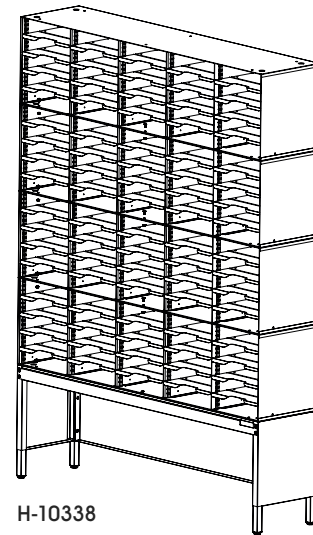

¡PRECAUCIÓN! No estibe más de cuatro clasificadores de correo.

PARTES PARA KIT DE ANCLAJE PARA PARED

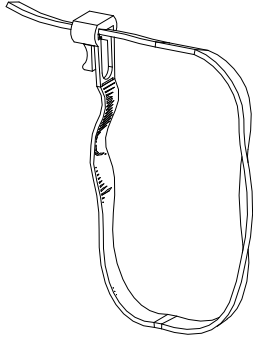

2 Cinchos

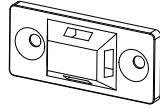

2 Soporte de
Instalación en Pared



2 Soportes de Metal

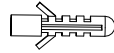

4 Taquetes de
Plástico



4 Tornillos ST3.5 x 38 mm



2 Pernos M6 x 12 mm



2 Tuercas M6

ENSAMBLE DEL KIT DE ANCLAJE PARA PARED

Diagrama 7

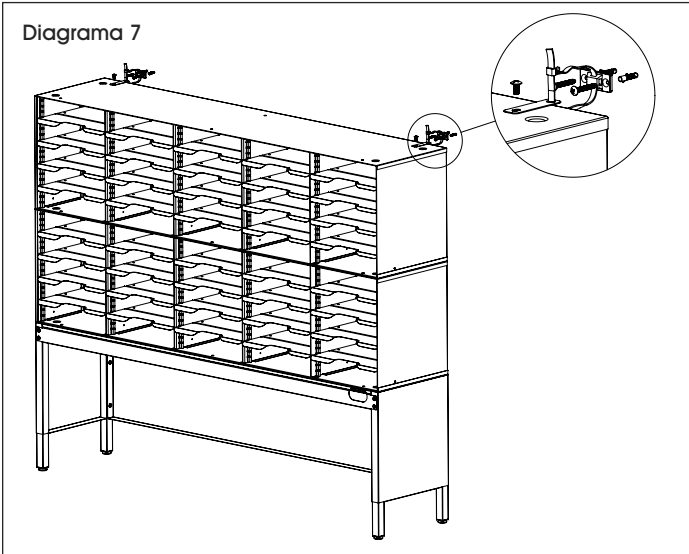

1. Marque los orificios en la pared donde se colocarán los taquetes de plástico. Perfore los orificios utilizando una broca de 5/16".
 2. Instale en la pared el soporte para pared con dos tornillos ST3.5 x 38 mm y dos taquetes de plástico M8 x 36 mm. (Vea Diagrama 7)
 3. Asegure el soporte de metal a la parte superior del clasificador de correo usando una tuerca M6 y un perno M6 x 12 mm. (Vea Diagrama 7)
-  **NOTA:** El extremo con el orificio ranurado se debe fijar al clasificador de correo.
4. Apriete el cincho para evitar que se vuelque. Repita la operación para el otro lado del clasificador de correo.

ULINE

800-295-5510
uline.mx

CLASSE-COURRIERS SUR PIED

OUTILS REQUIS

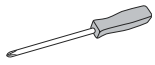

Tournevis
cruziforme

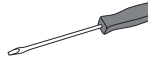

Tournevis à tête plate
(optionnel)



Perceuse
(optionnel)



Clé de 10 mm



Maillet en
caoutchouc



Mèche de perceuse
de 5/16 po (optionnel)



Montage à deux
personnes recommandé

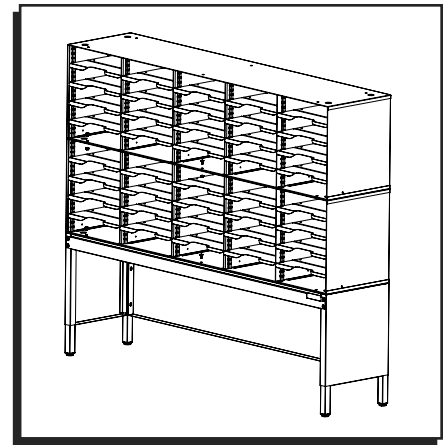

PIÈCES POUR LA BASE

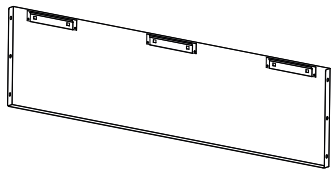

Panneau arrière x 1

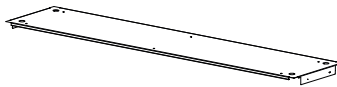

Panneau supérieur x 1



Profilé de soutien avant x 1

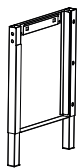

Panneau latéral
gauche x 1

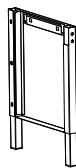

Panneau latéral
droit x 1

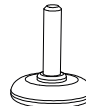

Patte de nivellement
réglable x 4



Boulon M6 x 12 mm
x 10

MONTAGE DE LA BASE

1. Insérez les pattes de nivellement réglables dans l'extrémité des pieds du panneau latéral. (Voir Figure 1)

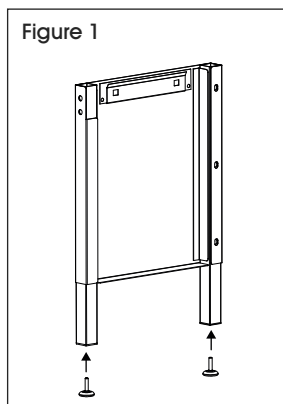

2. Placez le panneau supérieur à l'envers. Fixez le panneau latéral droit en insérant les languettes de verrouillage dans les trous carrés correspondants du panneau supérieur. Tapotez légèrement avec un maillet en caoutchouc pour permettre aux languettes de s'enclencher complètement. Répétez pour le panneau latéral gauche. (Voir Figure 2)



REMARQUE : Les languettes de verrouillage peuvent être ajustées avec un tournevis à tête plate pour faciliter le montage.



REMARQUE : Les trois trous à l'intérieur des pieds doivent être à l'arrière, près de la bride la plus longue.

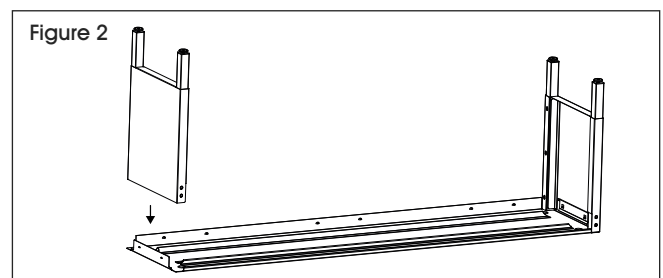

MONTAGE DE LA BASE SUITE

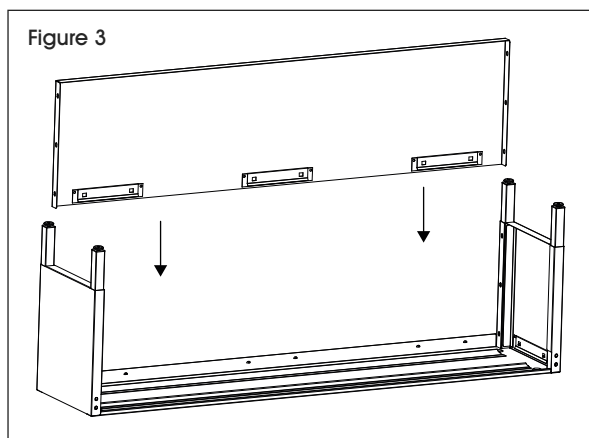

3. Fixez le panneau arrière à l'intérieur des panneaux latéraux et supérieur en insérant les languettes de verrouillage dans les trous carrés correspondants du panneau supérieur. (Voir Figure 3)

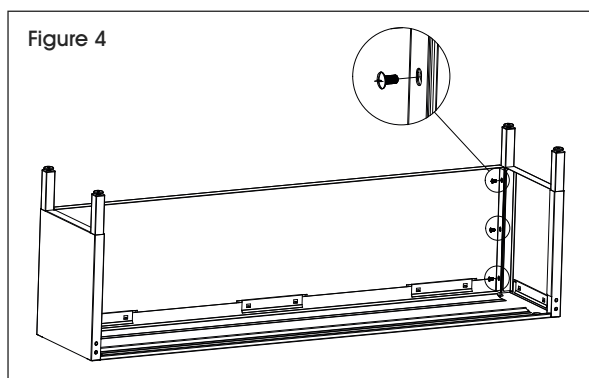

4. Insérez six boulons M6 x 12 mm pour fixer le panneau arrière aux panneaux latéraux et supérieur au moyen d'un tournevis cruciforme. (Voir Figure 4)

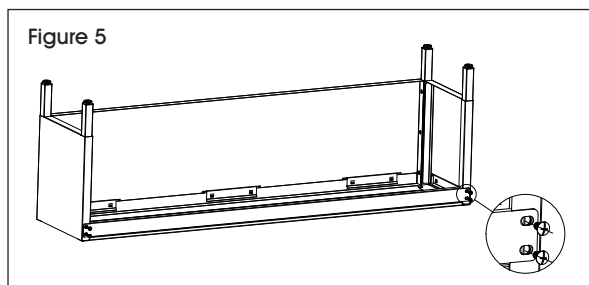

5. Attachez le profilé de soutien avant aux panneaux latéraux en insérant quatre boulons M6 x 12 mm au moyen d'un tournevis cruciforme. (Voir Figure 5)

PIÈCES POUR CLASSE-COURRIER

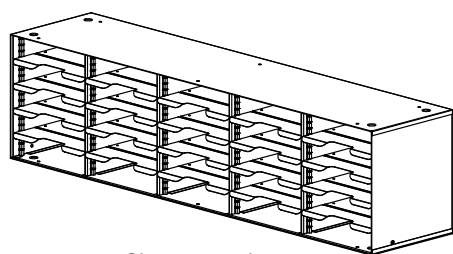

Classe-courrier



Boulon
M6 x 10 mm



Écrou M6

	NOMBRE DE CLASSE-COURRIERS	BOULON M6 x 10 MM	ÉCROU M6
H-10336	2	12	12
H-10337	3	18	18
H-10338	4	24	24

MONTAGE DU CLASSE-COURRIER SUITE

1. Posez un classe-courrier sur la base. Fixez le classe-courrier à la base à l'aide de six boulons M6 x 10 mm et six écrous M6 au moyen d'un tournevis cruciforme et une clé de 10 mm. Les trous se trouvent à l'avant et à l'arrière du classe-courrier dans les colonnes situées sur les extrémités gauche, droite et au centre. (Voir Figure 6)

 **REMARQUE :** Les tablettes du classe-courrier peuvent être retirées pour offrir plus d'espace lors du serrage des boulons et des écrous.

2. Placez le deuxième classe-courrier par-dessus le classe-courrier fixé. Attachez le classe-courrier au classe-courrier fixé à l'aide de six boulons M6 x 10 mm et six écrous M6 au moyen d'un tournevis cruciforme et une clé de 10 mm. Si vous montez un classe-courrier avec 75 ou 100 fentes, répétez l'opération pour les autres classe-courriers. (Voir Figure 6)

MONTAGE COMPLÉTÉ

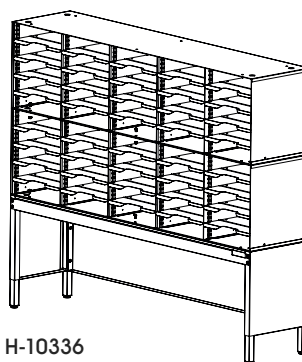

H-10336

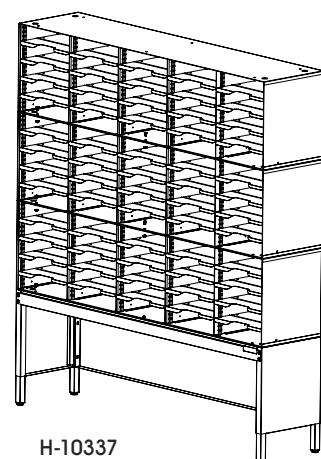

H-10337

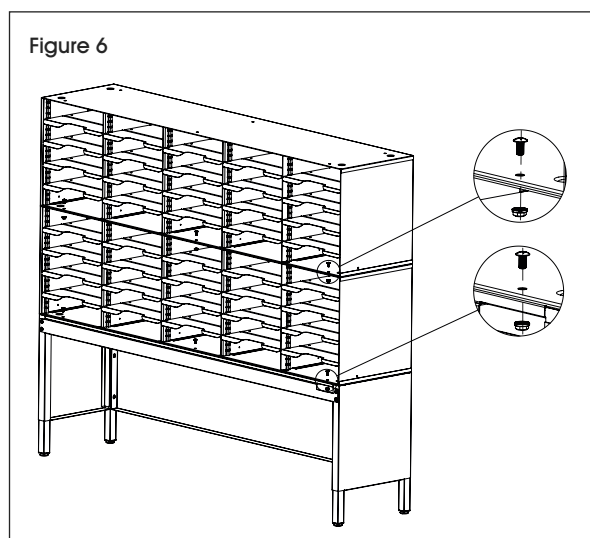
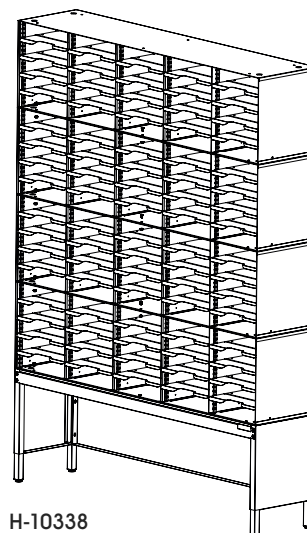

Figure 6



H-10338



MISE EN GARDE! N'empilez pas plus de quatre classe-courriers.

PIÈCES POUR DISPOSITIF D'ANCRAGE MURAL

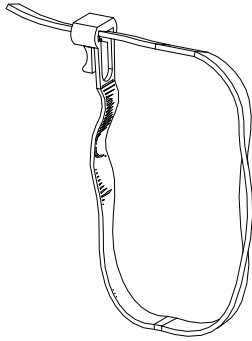

Attache-câble x 2

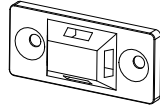

Support mural x 2



Support métallique x 2

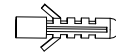

Ancrage en plastique x 4



Vis ST3.5 x 38 mm x 4



Boulon M6 x 12 mm x 2



Écrou M6 x 2

MONTAGE DU DISPOSITIF D'ANCRAGE MURAL

Figure 7

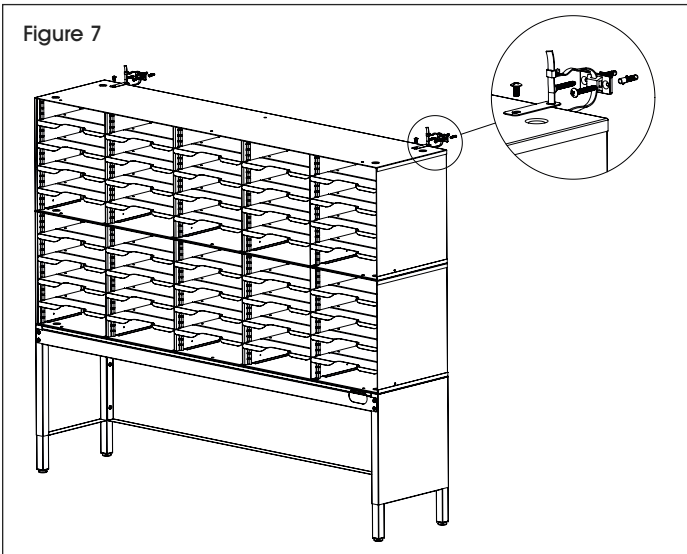

1. Marquez l'emplacement des trous sur le mur pour les ancrages en plastique. Percez les trous en utilisant une mèche de perceuse de 5/16 po.
2. Fixez le support d'ancrage au mur avec deux vis ST3.5 x 38 mm et deux ancrages en plastique. (Voir Figure 7)
3. Fixez le support métallique au sommet du classe-courrier à l'aide d'un écrou M6 et d'un boulon M6 x 12 mm. (Voir Figure 7)



REMARQUE : L'extrémité avec le trou oblong doit être fixée au classe-courrier.

4. Resserrez l'attache-câble pour empêcher tout basculement. Répétez l'opération de l'autre côté du classe-courrier.

ULINE

1-800-295-5510
uline.ca