

ULINE H-10371

DESIGNER COLLECTION – STORAGE L-DESK

1-800-295-5510
 uline.com

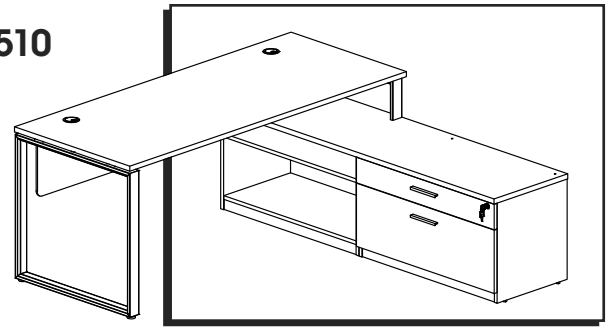

TOOLS NEEDED

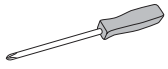

Phillips Screwdriver



Allen Wrench
(Included)



Drill
(Optional)



Two Person Assembly
 Recommended

PARTS

STARTER DESK

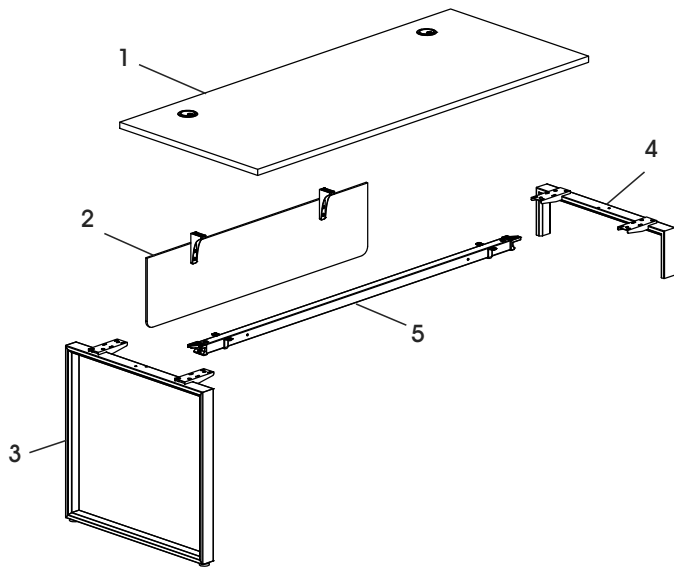

#	DESCRIPTION	QTY
1	Desktop	1
2	Modesty Panel	1
3	Leg Frame	1
4	Short Leg Frame	1
5	Support Bar	1

CREENZA RETURN

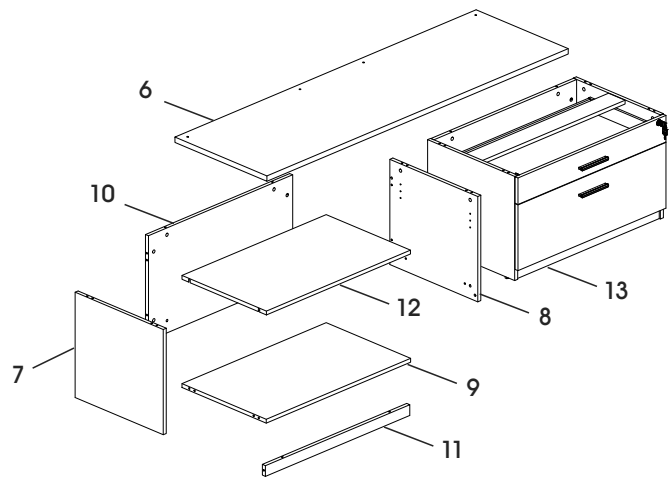

#	DESCRIPTION	QTY
6	Return Desktop	1
7	Left Side Panel	1
8	Right Side Panel	1
9	Bottom Panel	1
10	Back Panel	1
11	Skirt Panel	1
12	Bookshelf Panel	1
13	Low Lateral File Cabinet	1

HARDWARE

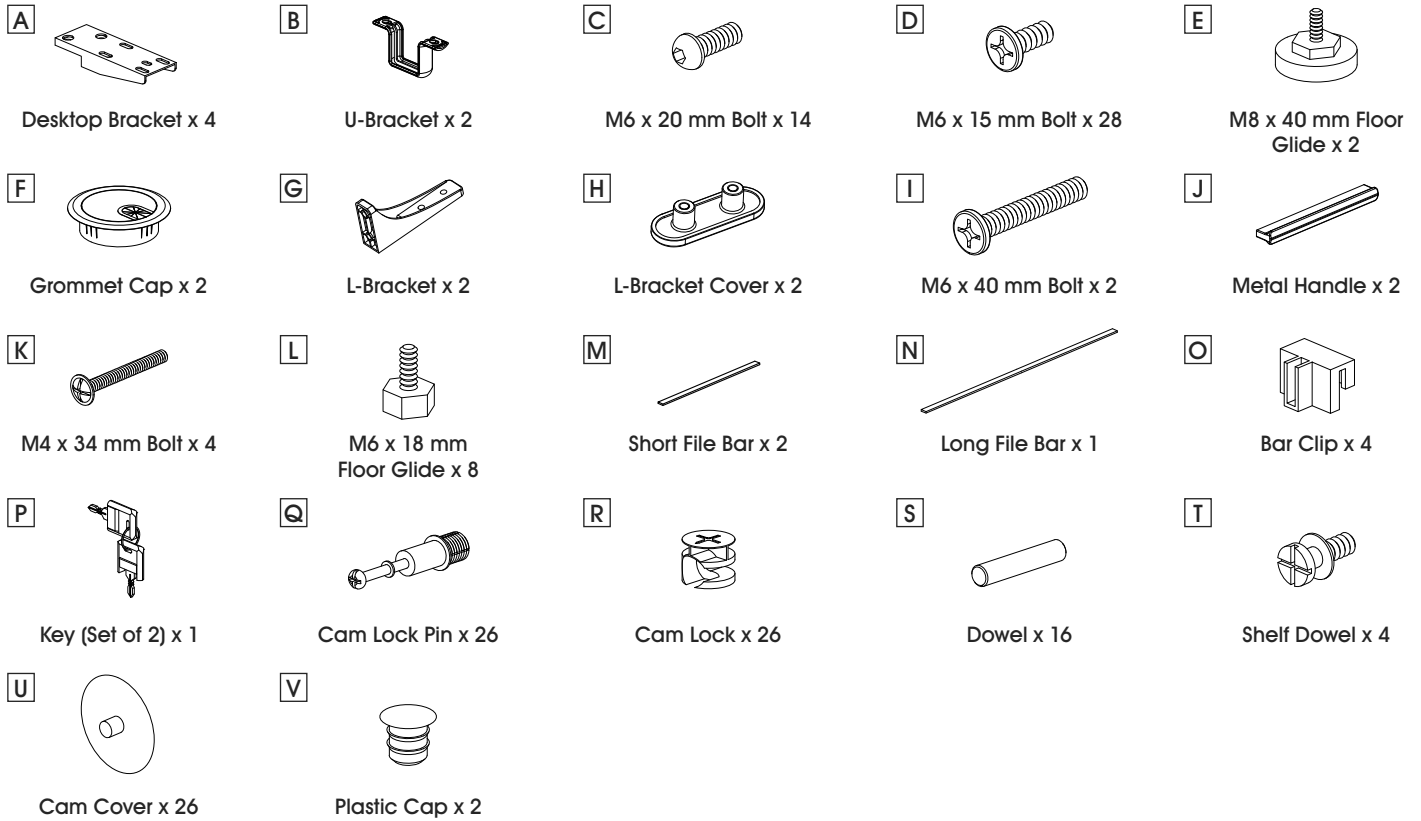

ASSEMBLY

STARTER DESK ASSEMBLY

1. Install M8 x 40 mm floor glides (E) on leg frame (3). Turn leg frame upright. (See Figure 1)

2. Align support bar (5) with holes on leg frame (3) and short leg frame (4) and secure using three M6 x 20 mm bolts (C) on each side. Tighten using Allen wrench. (See Figure 2)

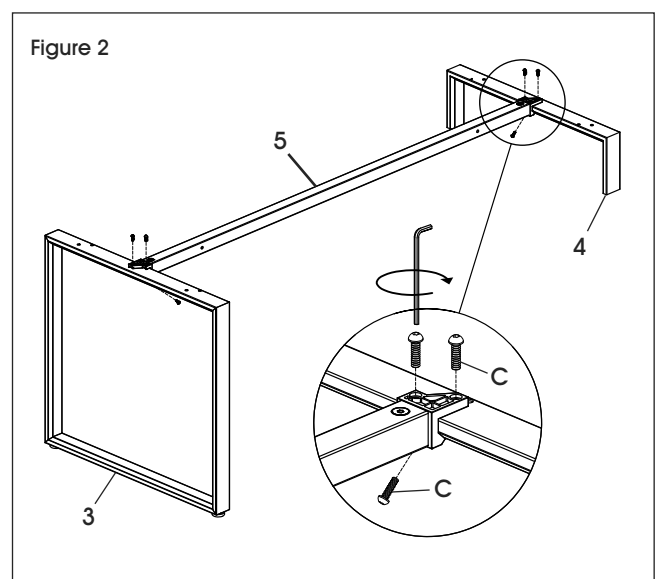
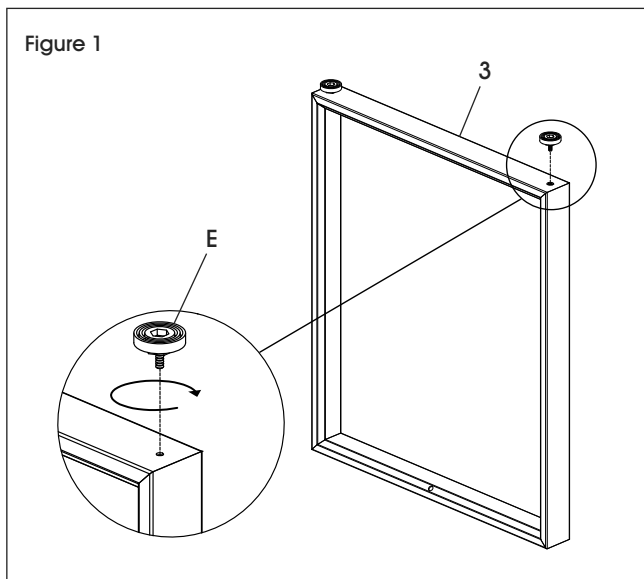

ASSEMBLY CONTINUED

- Attach four desktop brackets (A) to leg frames (3 and 4) using two M6 x 20 mm bolts (C) per bracket. Tighten using Allen wrench. (See Figure 3)

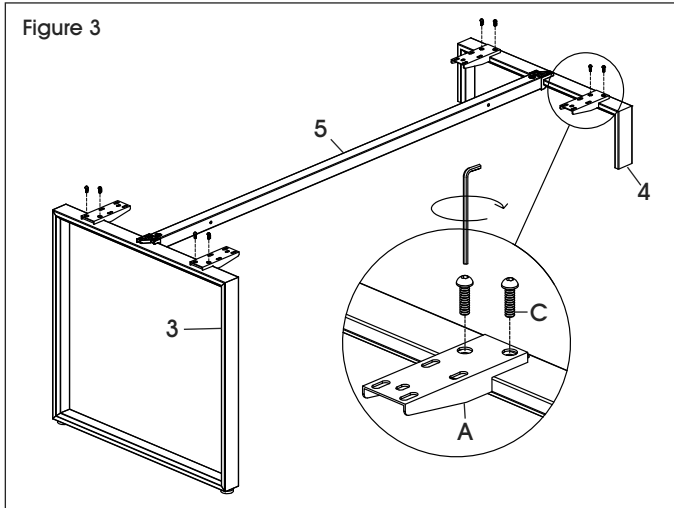

 **NOTE:** Determine whether desk will be set up for right-handed or left-handed configuration. Assembly of a right-handed storage L-desk is shown in the following figures. For left-handed configuration, the short leg frame will be placed on the opposite side of desktop.

- With second person, place desktop (1) upside down with holes facing up. Turn assembled desk frame upside down. Use four M6 x 15 mm bolts (D) to secure each desktop bracket (A) to desktop (1). Tighten using Phillips screwdriver. (See Figure 4)

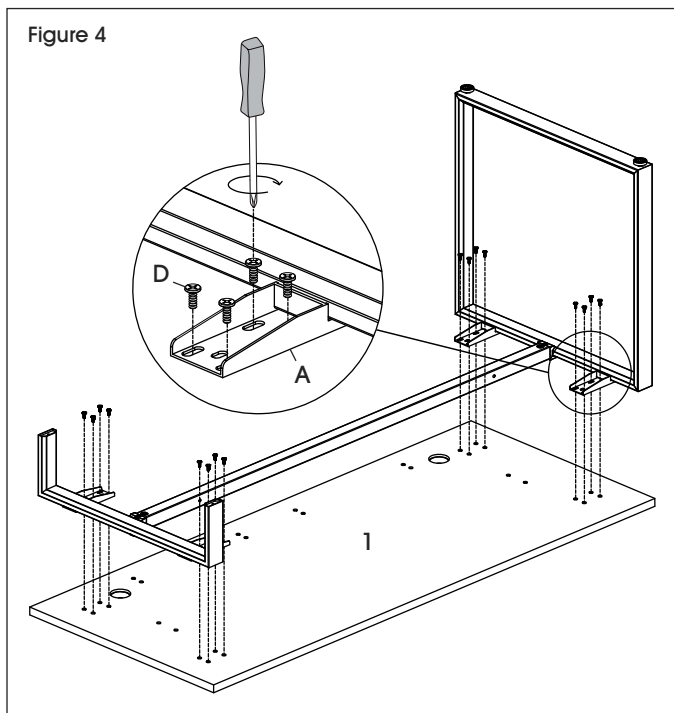

- Align U-brackets (B) with holes in desktop and use two M6 x 15 mm bolts (D) to secure each bracket. Tighten using Phillips screwdriver. (See Figure 5)

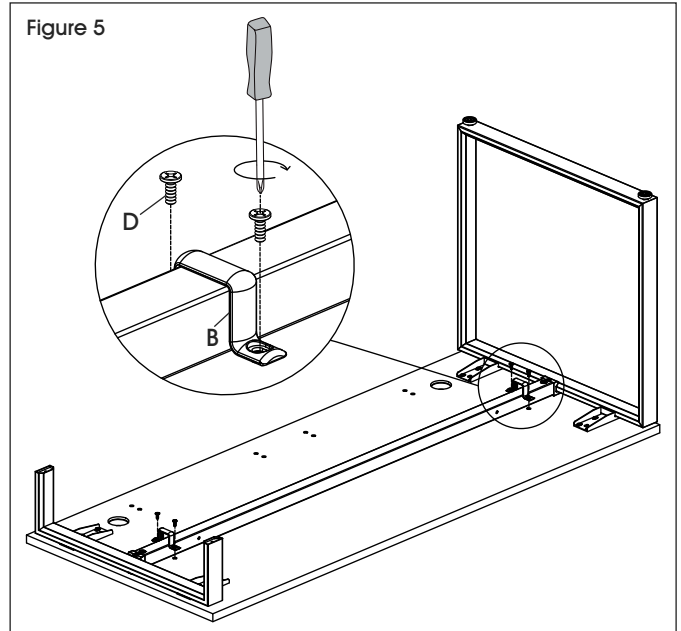

- Align L-brackets (G) and L-bracket covers (H) with holes in modesty panel (2). Use two M6 x 15 mm bolts (D) to secure each bracket and cover set. Tighten using Phillips screwdriver. (See Figure 6)

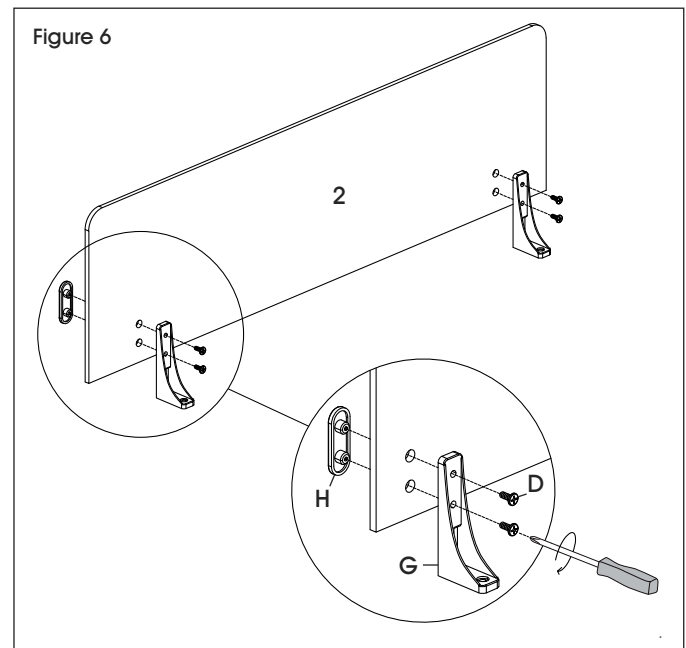

ASSEMBLY CONTINUED

- Align L-brackets (G) with holes in desktop (1) and use two M6 x 15 mm bolts (D) to secure each bracket. Tighten using Phillips screwdriver. (See Figure 7)

 **NOTE:** Install modesty panel on side closest to large leg frame.

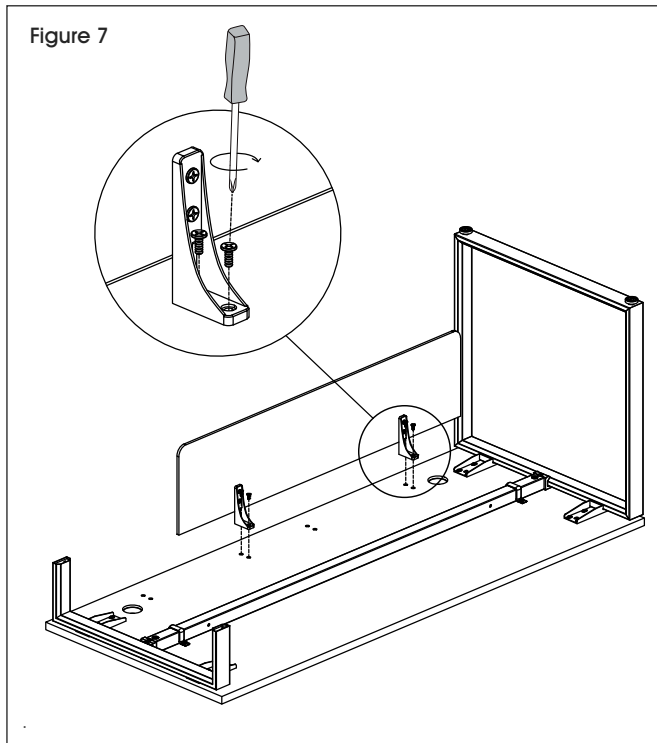

CREDENZA RETURN ASSEMBLY

- Lock drawers of the low lateral file cabinet (13). With second person, set file cabinet on side or back.
- Insert M6 x 18 mm floor glides (L) on bottom of file cabinet. Glides can be adjusted to compensate for uneven floors. (See Figure 8)

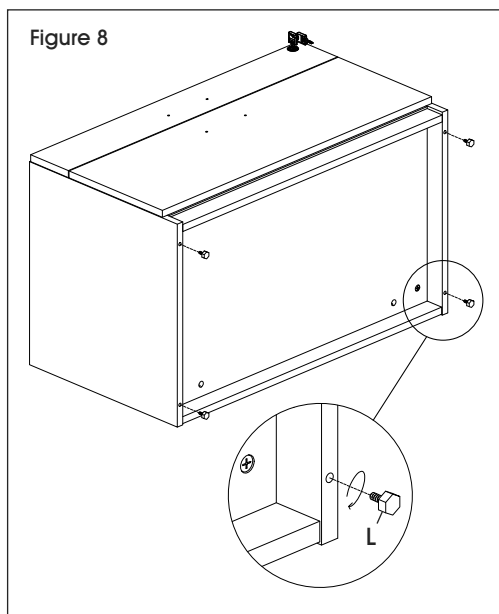

- With second person, set file cabinet upright. Unlock drawers. Using a Phillips screwdriver, remove handle (J) mounted inside drawer and use same screws (K) to attach handle to front of drawer. Repeat for second drawer. Set cabinet aside. (See Figure 9)

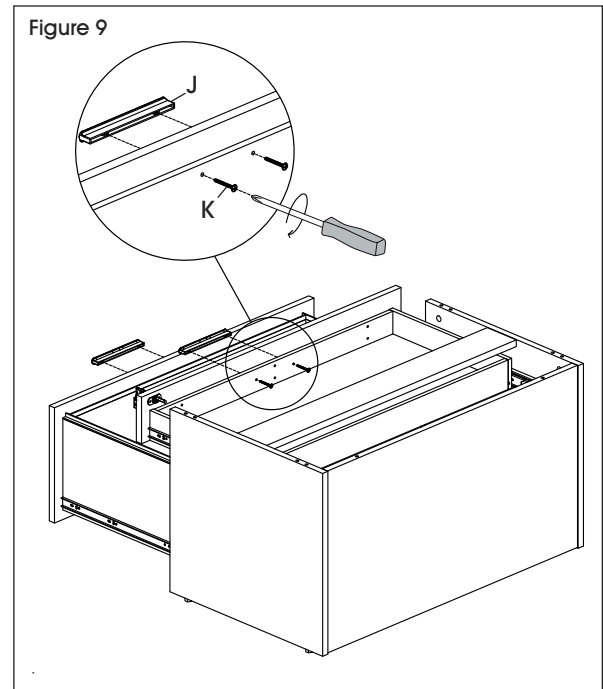

- Start building bookcase portion by installing two cam lock pins (Q) in bottom panel (9). Insert two cam locks (R) into corresponding holes in skirt panel (11). Fit bottom panel and skirt panel together and turn cam lock clockwise until it locks. (See Figure 10)

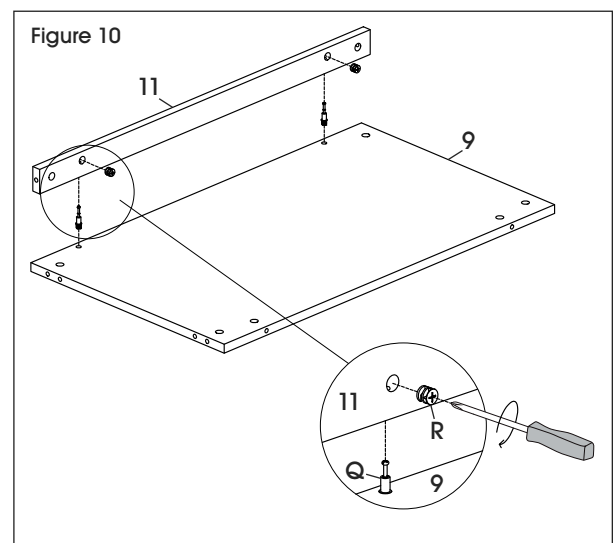

ASSEMBLY CONTINUED



IMPORTANT! Turn cam lock (R) 1/4 to the right to lock. Ensure arrow is pointing toward edge of panel before inserting into panel's hole.

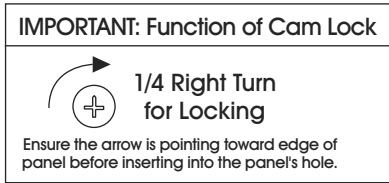

IMPORTANT! Cam lock pins (Q) must be tightened once inserted into panel. To tighten, grasp lower part of cam lock pin and tighten using a Phillips screwdriver.

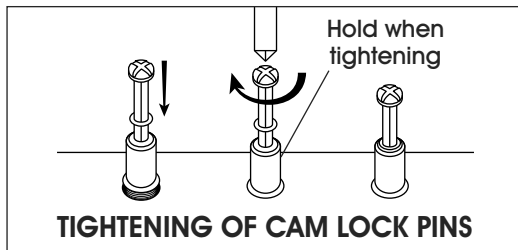

NOTE: Cam lock covers (U) can be applied once cam locks are tightened for a finished look.

5. Install two cam lock pins (Q) into back panel (10). Insert two cam locks (R) into corresponding holes in bottom panel (9). Fit bottom panel and back panel together and tighten cam locks. (See Figure 11)

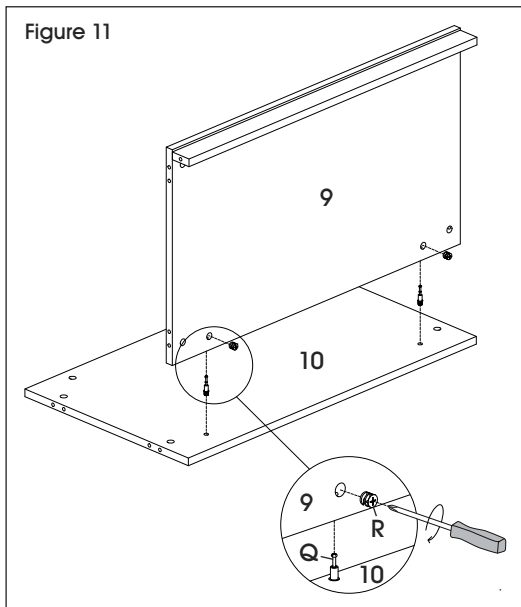

6. Install five cam lock pins (Q) and four dowels (S) on each side panel (7 and 8). Insert cam locks (R) into corresponding holes in bottom panel (9), back panel (10) and skirt panel (11). Tighten cam locks. (See Figure 12)

7. Insert M6 x 18 mm floor glides (L) into the bottom edge of side panels (7 and 8). Glides can be adjusted for uneven floors. (See Figure 12)

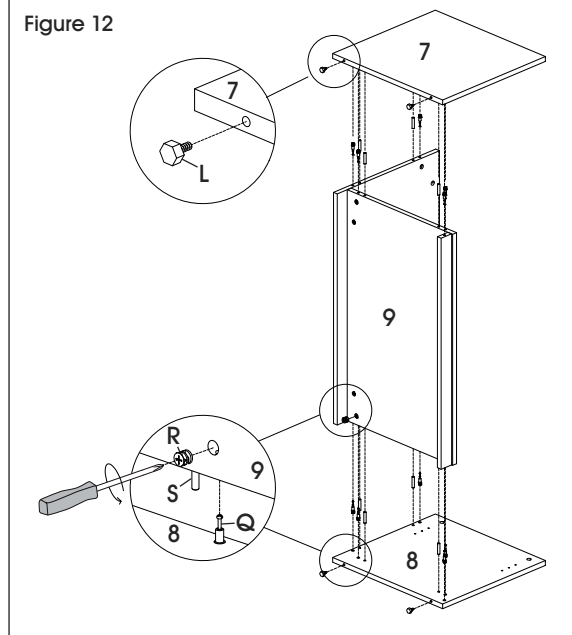

8. With second person, place return desktop (6) upside down with holes facing up. Install 12 cam lock pins (Q) into return desktop. (See Figure 13)

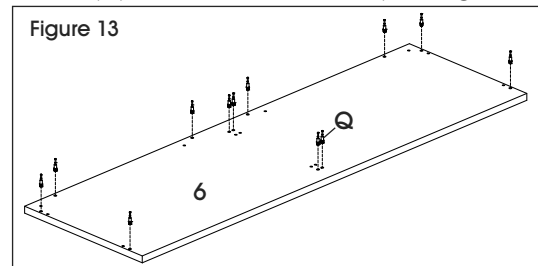

9. With second person, turn assembled bookcase upright and place next to low lateral file cabinet (13). Insert eight dowels (S) and 12 cam locks (R) into top edges of bookcase and lateral file cabinet. (See Figure 14)



NOTE: If assembling a left-handed configuration, place bookshelf on the right side of the low lateral file cabinet.

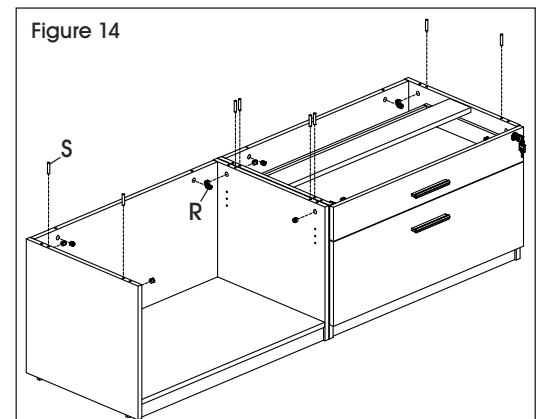

ASSEMBLY CONTINUED

10. Open top drawer of lateral file cabinet and locate plastic tab on drawer slides. Push up on one tab and push down on opposite tab to release drawer and remove.
11. With second person, turn return desktop (6) over and attach to bookcase and lateral file cabinet (13). Tighten cam locks. (See Figure 15)

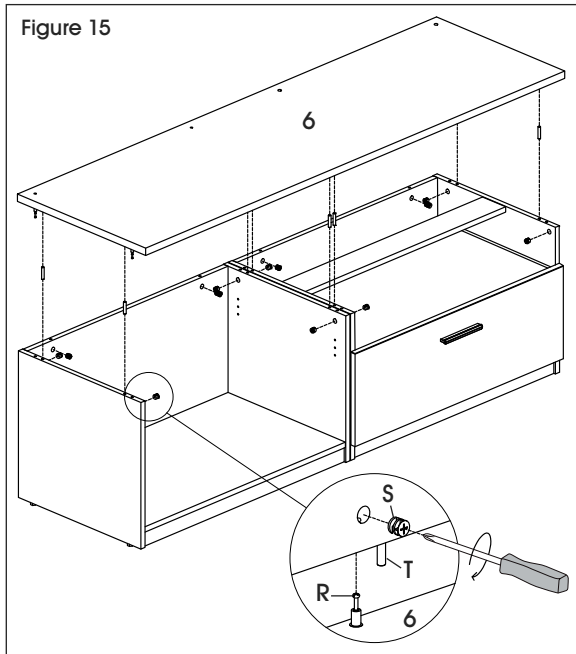

12. Replace top drawer of low lateral file cabinet.

FINAL ASSEMBLY

1. With second person, place the credenza return in desired location. Carefully pick up the assembled starter desk and align its short leg frame (4) with the corresponding holes in the return desktop (6). Attach starter frame to the credenza return using two M6 x 40 mm bolts (I). (See Figure 16)

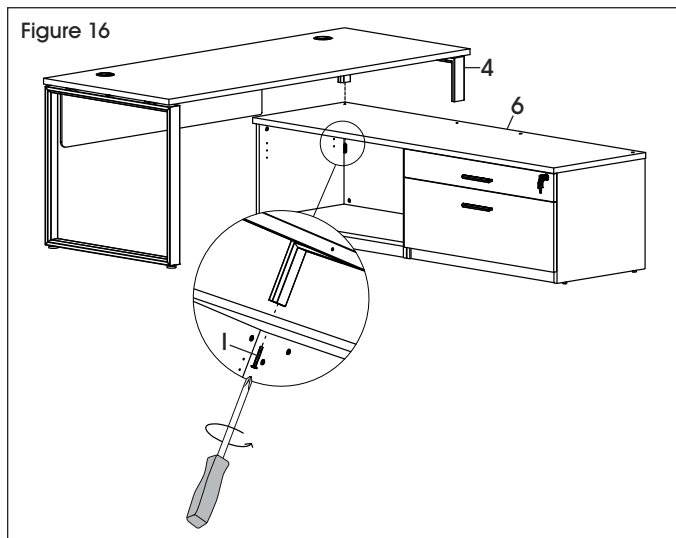

2. Insert shelf dowels (T) into the side panels of bookcase. Place bookshelf panel (12) on top of shelf dowels. Tighten shelf supports in underside of shelves for a secure fit. (See Figure 17)

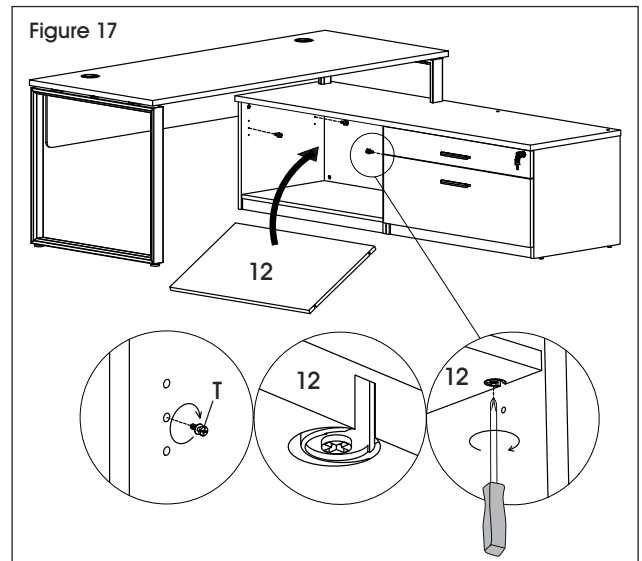

3. Insert grommet caps (F) into the desktop (1) and plastic caps (V) into the holes of the return desktop (6). (See Figure 18)

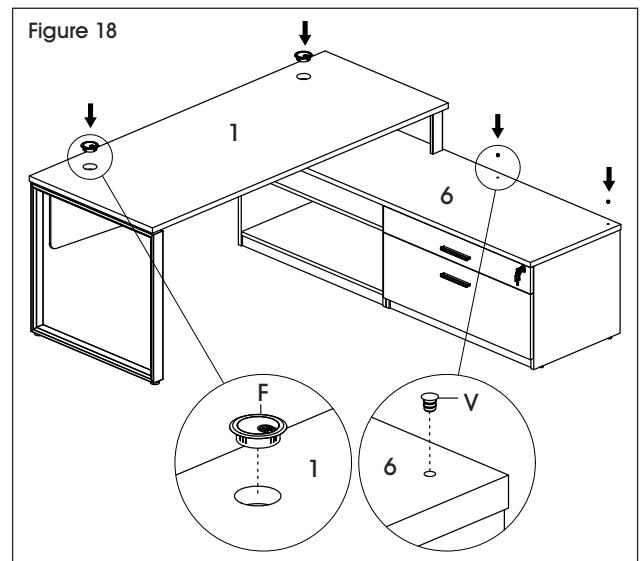

 **NOTE:** If using the optional seat cushion, plastic caps do not need to be inserted into return desktop. Seat cushion will cover the exposed holes.

 **NOTE:** Seat cushion rests on top of the low credenza. Rubber pads underneath seat cushion will secure it in place.

COMPLETED ASSEMBLY

Right Hand

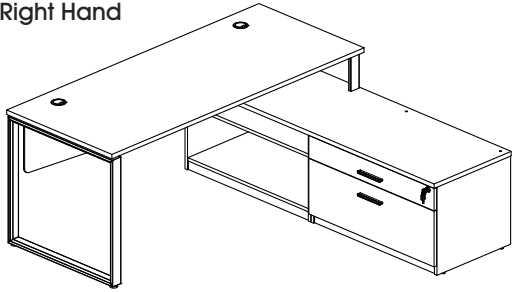

Left Hand

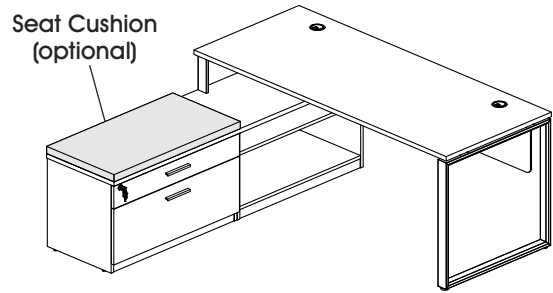
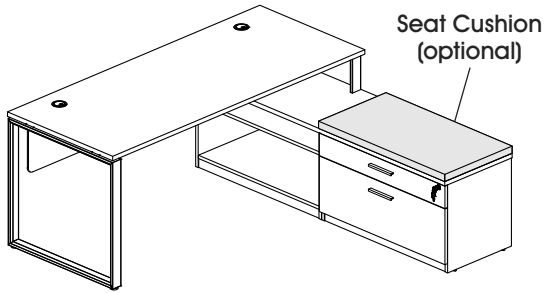
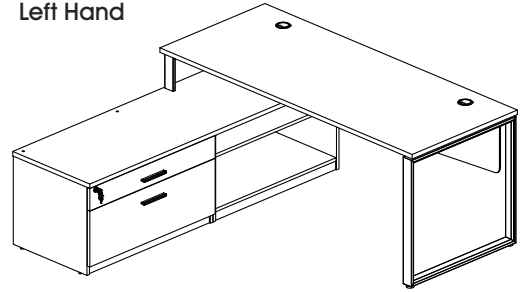

FILE BAR INSTALLATION

Figure 19

Front-to-Back

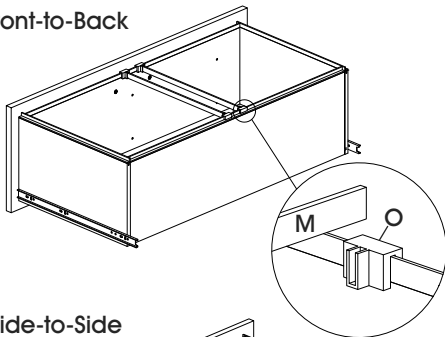

Side-to-Side

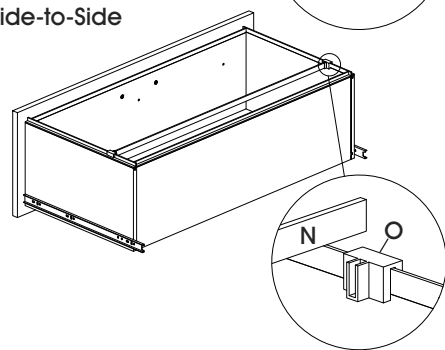

1. To hang files from front-to-back, attach two bar clips (O) to back of drawer and two to front of drawer. Insert two short file bars (M). (See Figure 19)
2. To hang files from side-to-side, attach one bar clip (O) to each side of drawer and insert one long file bar (N). (See Figure 19)

ULINE

1-800-295-5510
uline.com

ULINE H-10371

COLECCIÓN DE DISEÑO – ESCRITORIO EN L PARA ALMACENAMIENTO

800-295-5510
uline.mx

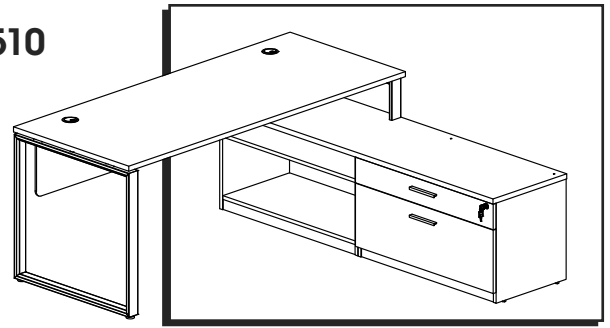

HERRAMIENTAS NECESARIAS

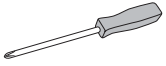

Desarmador de Cruz



Llave Allen
(Incluida)



Taladro
(Opcional)



Se Recomienda Armar
Entre Dos Personas

PARTES

ESCRITORIO BÁSICO

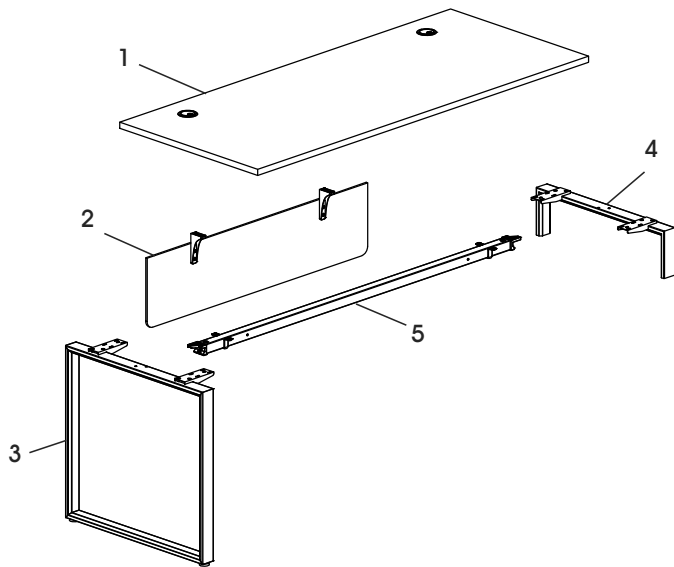





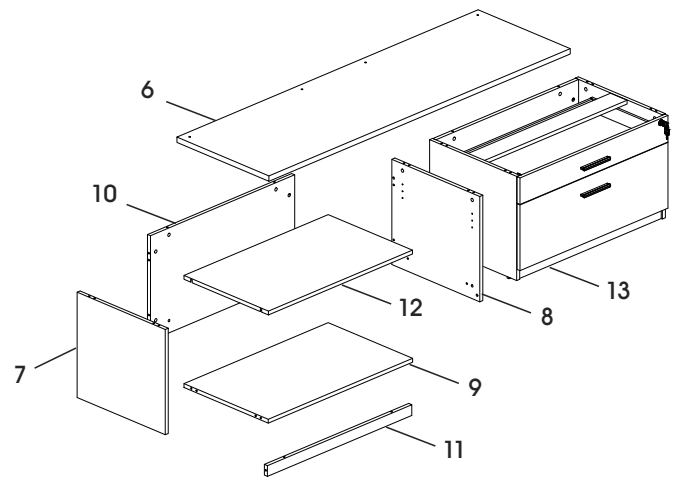





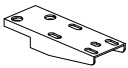





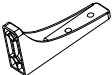
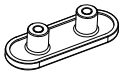
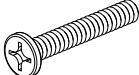

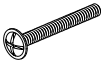
#	DESCRIPCIÓN	CANT.
1	Escritorio	1
2	Recato	1
3	Armazón de la Pata	1
4	Armazón de la Pata Corta	1
5	Barra de Soporte	1

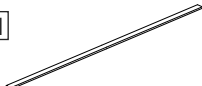
RETORNO DE CREDENZA

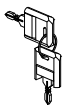
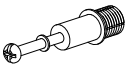

#	DESCRIPCIÓN	CANT.
6	Cubierta del Retorno para Escritorio	1
7	Panel Lateral Izquierdo	1
8	Panel Lateral Derecho	1
9	Panel Inferior	1
10	Panel Posterior	1
11	Zoclo	1
12	Panel del Librero	1
13	Archivero Lateral Inferior	1

TORNILLERÍA

A		B		C		D		E	
	4 Soportes para Cubierta de Escritorio		2 Soportes en U		14 Pernos M6 x 20 mm		28 Pernos M6 x 15 mm		2 Tapas Niveladoras M8 x 40 mm
F		G		H		I		J	
	2 Tapas de Ojal		2 Soportes en L		2 Cubiertas para Soporte en L		2 Pernos M6 x 40 mm		2 Asas de Metal
K		L		M		N		O	
	4 Pernos M4 x 34 mm		8 Tapas Niveladoras M6 x 18 mm		2 Barras Cortas para Carpetas		1 Barra Larga para Carpetas		4 Clips para Barra
P		Q		R		S		T	
	LLaves (Set de 2)		26 Pasadores para Tuercas Minifix		26 Tuercas Minifix		16 Taquetes		4 Taquetes para Repisa
U		V							
	26 Tapas para Minifix		2 Tapas de Plástico						

ENSAMBLE

ENSAMBLE DEL ESCRITORIO BÁSICO

1. Instale las tapas niveladoras M8 x 40 mm (E) en los armazones de las patas (3). Voltee el armazón de las patas hacia arriba. (Vea Diagrama 1)

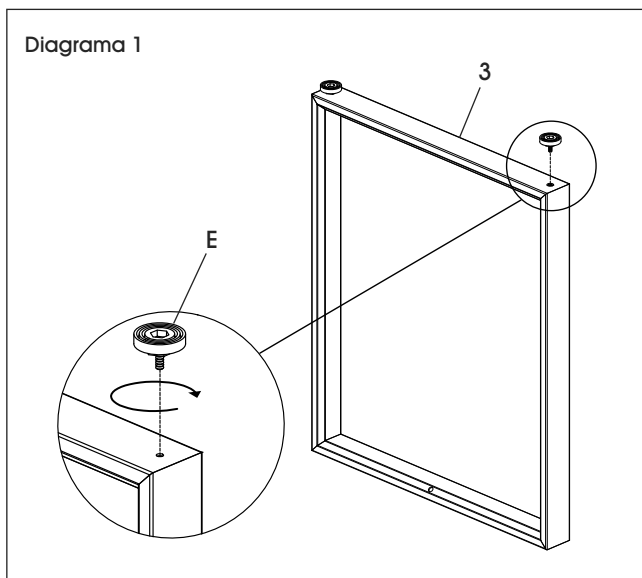

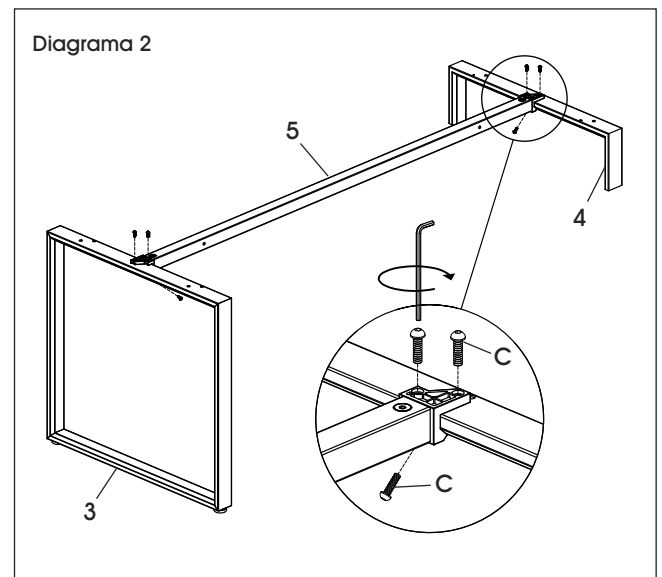

2. Alinee la barra de soporte (5) con los orificios del armazón de la pata (3) y el armazón de la pata corta (4) y fíjelos usando tres pernos M6 x 20 mm (C) en cada lado. Apriete con la llave Allen. (Vea Diagrama 2)

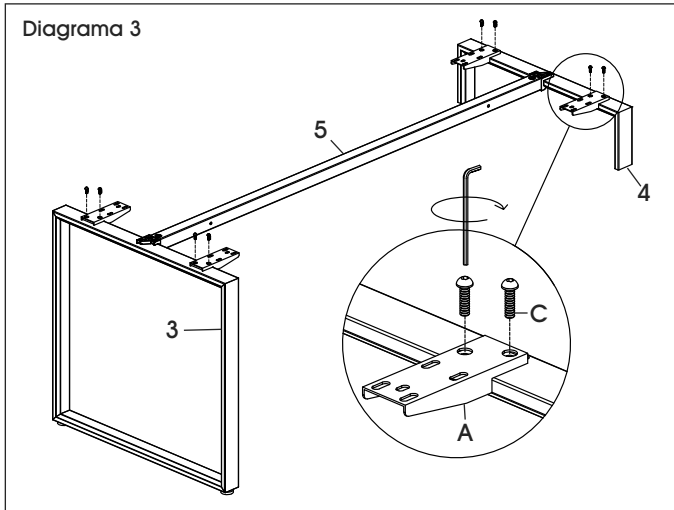

CONTINUACIÓN DEL ENSAMBLE

3. Fije cuatro soportes para cubierta de escritorio (A) a los armazones de la pata (3 y 4) usando dos pernos M6 x 20 mm (C) por soporte. Apriete con la llave Allen. (Vea Diagrama 3)



 **NOTA:** Determine si el escritorio en L estará configurado para zurdos o diestros. En los siguientes diagramas se muestra el ensamble de un escritorio en L para almacenamiento para diestros. Para la configuración para zurdos, la pata corta se colocará en el lado opuesto del escritorio.

4. Entre dos personas, coloquen el escritorio ensamblado (1) boca abajo con los orificios hacia arriba. Volteen el armazón del escritorio ensamblado. Use cuatro pernos M6 x 15 mm (D) para fijar cada soporte para cubierta de escritorio (A) al escritorio (1). Apriete utilizando un desarmador de cruz. (Vea Diagrama 4)

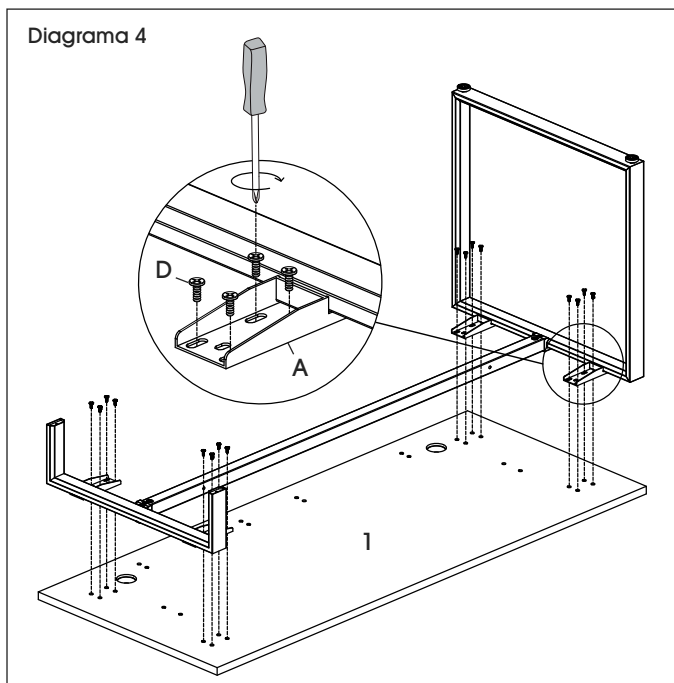

5. Alinee los soportes en U (B) con los orificios de la cubierta de escritorio y use dos pernos M6 x 15 mm (D) para fijar cada soporte. Apriete utilizando un desarmador de cruz. (Vea Diagrama 5)

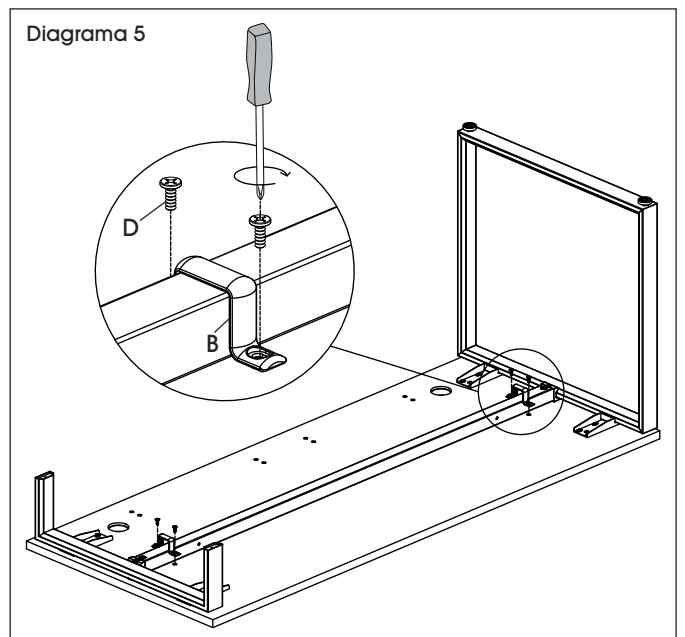

6. Alinee los soportes en L (G) y sus cubiertas (H) con los orificios del recato (2). Use dos pernos M6 x 15 mm (D) para fijar cada soporte y el set de la cubierta. Apriete utilizando un desarmador de cruz. (Vea Diagrama 6)

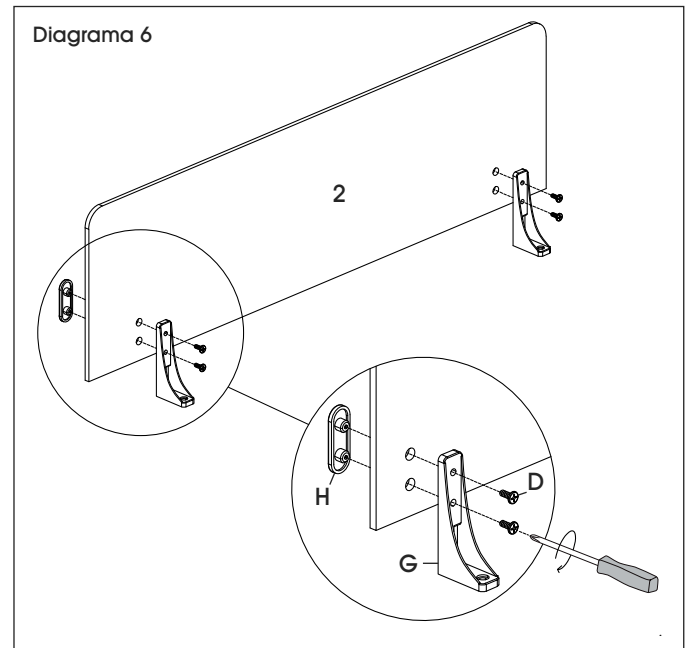

CONTINUACIÓN DEL ENSAMBLE

7. Alinee los soportes en L (G) con los orificios de la cubierta (1) y use dos pernos M6 x 15 mm (D) para fijar cada soporte. Apriete utilizando un desarmador de cruz. (Vea Diagrama 7)

 **NOTA:** Instale el recato en el lado más próximo al armazón de la pata larga.

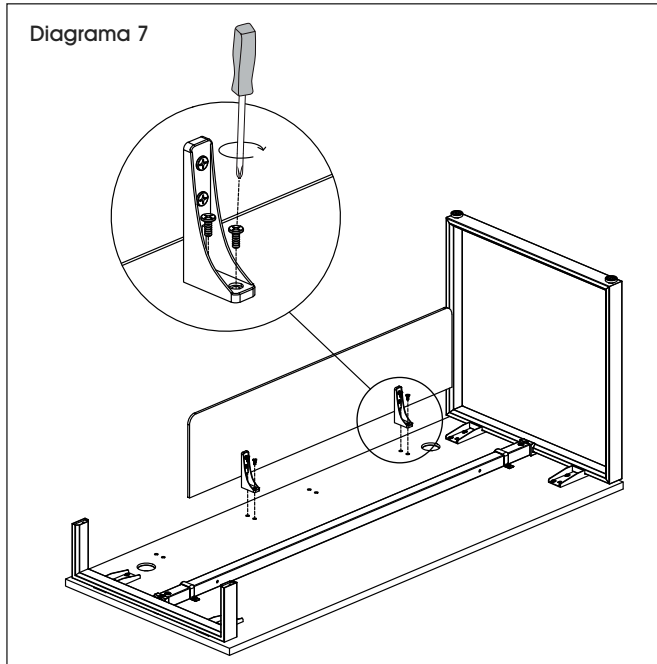

ENSAMBLE DEL RETORNO DE LA CREDENZA

1. Asegure los cajones del archivero lateral inferior (13). Entre dos personas coloquen el archivero de lado.
2. Inserte las tapas niveladoras M6 x 18 mm (L) en la parte inferior del archivero. Las tapas niveladoras se pueden ajustar para compensar el desnivel del piso. (Vea Diagrama 8)

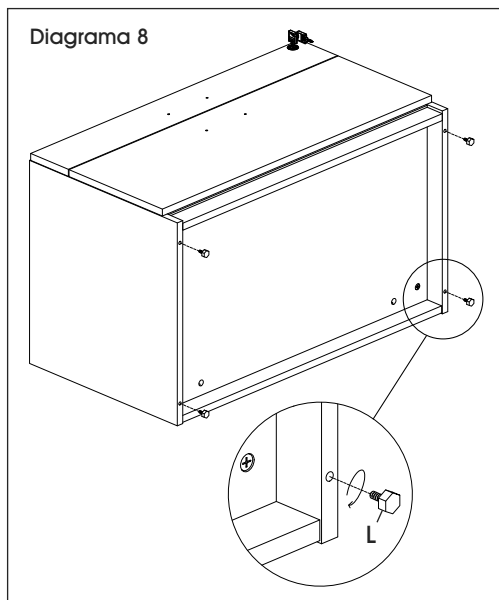

3. Entre dos personas enderecen el archivero. Abra los cajones. Con un desarmador de cruz retire las asas (J) instaladas por dentro de los cajones y use los mismos tornillos (K) para fijarlas al frente del cajón. Repita la operación para el segundo cajón. Ponga el archivero a un lado. (Vea Diagrama 9)

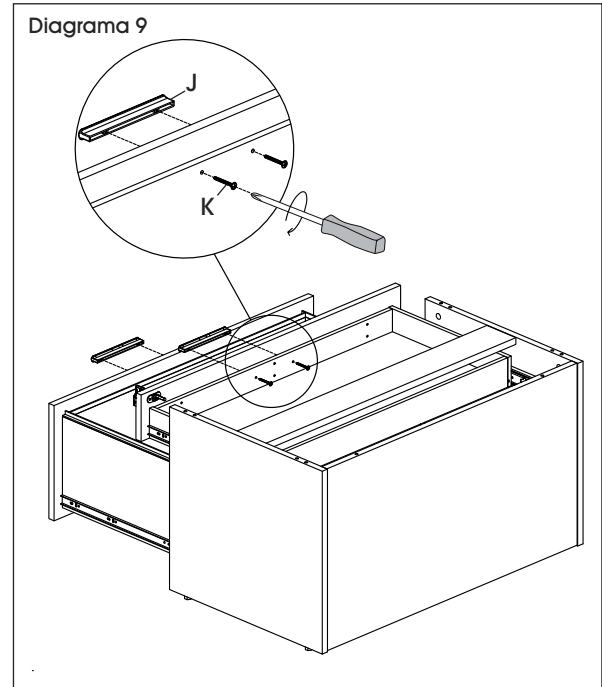

4. Comience a armar la parte del librero instalando dos pasadores para tuerca minifix (Q) en el panel inferior (9). Inserte dos tuercas minifix (R) en el orificio correspondiente del zoclo (11). Junte el panel inferior y el zoclo y gire la tuerca minifix en el sentido de las manecillas del reloj hasta que se bloquee. (Vea Diagrama 10)

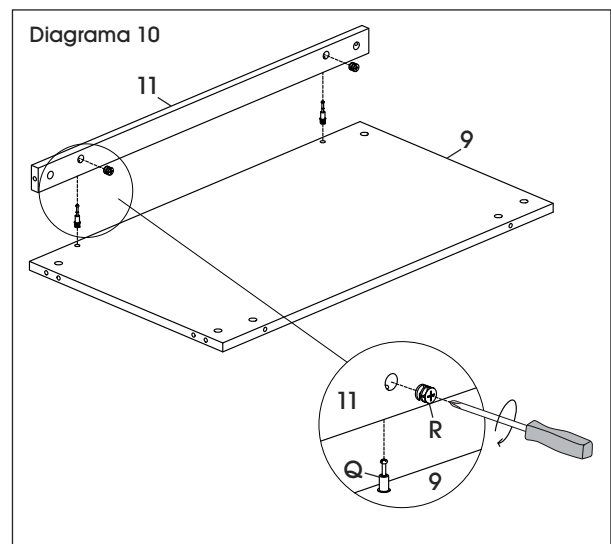

CONTINUACIÓN DEL ENSAMBLE



¡IMPORTANTE! Gire la tuerca minifix (R) 1/4 a la derecha para fijarla. Asegúrese de que la flecha apunte hacia el borde del panel antes de insertarla en el orificio del panel.

¡IMPORTANTE: Función de la Tuerca Minifix

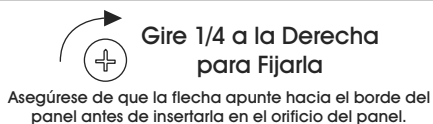

¡IMPORTANTE! Los pasadores para tuercas minifix (Q) se deben apretar una vez que se hayan insertado en el panel. Para ajustarlos, sostenga la parte inferior del pasador y apriete con el desarmador de cruz.

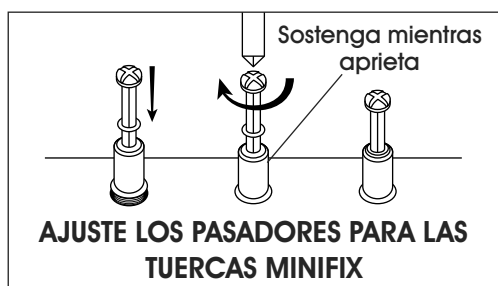

NOTA: Puede colocar las tapas para tuerca minifix (U) una vez que las haya apretado para darle una apariencia terminada.

5. Instale dos pasadores para tuercas minifix (Q) en el panel posterior (10). Inserte dos tuercas minifix (R) en el orificio correspondiente en el panel inferior (9). Junte los paneles inferior y posterior y apriete las tuercas minifix. (Vea Diagrama 11)

Diagrama 11

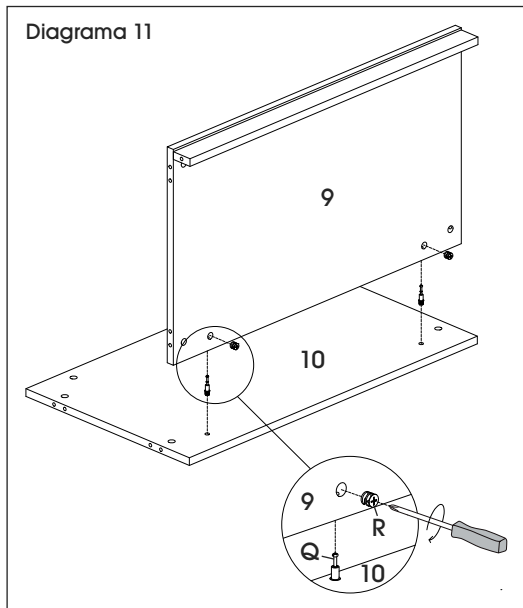

6. Instale cinco pasadores para tuercas minifix (Q) y cuatro taquetes (S) en cada panel lateral (7 y 8). Inserte las tuercas minifix (R) en los orificios correspondientes en el panel inferior (9), panel posterior (10) y el zoclo (11). Apriete las tuercas minifix. (Vea Diagrama 12)
7. Inserte las tapas niveladoras M6 x 18 mm (L) en el extremo inferior de los paneles laterales (7 y 8). Los niveladores se pueden ajustar en los pisos irregulares. (Vea Diagrama 12)

Diagrama 12

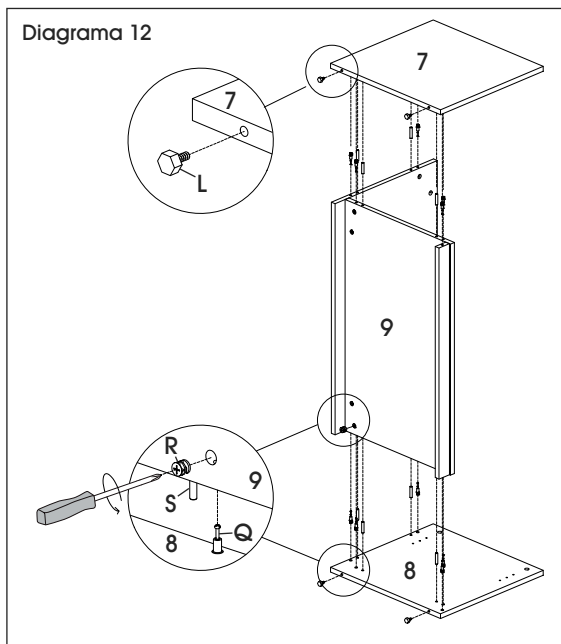

8. Entre dos personas coloquen el retorno para escritorio ensamblado (6) boca abajo con los orificios hacia arriba. Instale 12 pasadores para tuercas minifix (Q) en el retorno para escritorio. (Vea Diagrama 13)

Diagrama 13

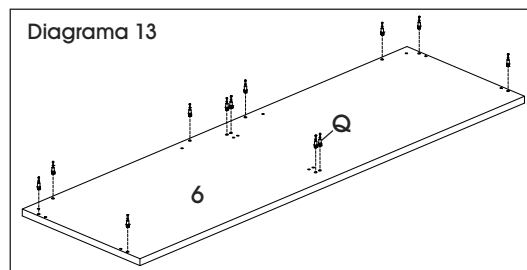

CONTINUACIÓN DEL ENSAMBLE

- Entre dos personas coloquen el librero ensamblado boca arriba y pónganlo junto al archivero lateral inferior (13). Inserte ocho taquetes (S) y 12 tuercas minifix (R) en los extremos superiores del librero y el archivero lateral. (Vea Diagrama 14)

 **NOTA:** Para la configuración para zurdos, coloque el librero del lado derecho del archivero lateral inferior.

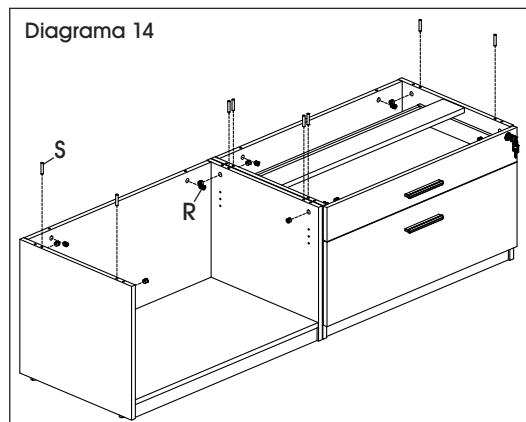

- Abra el cajón superior del archivero y localice la pestaña de plástico en los deslizadores del cajón. Levante una pestaña y presione la pestaña opuesta para liberar y luego sacar el cajón.
- Entre dos personas volteen el retorno para escritorio (6) y fíjelo al librero y al archivero lateral (13). Apriete las tuercas minifix. (Vea Diagrama 15)

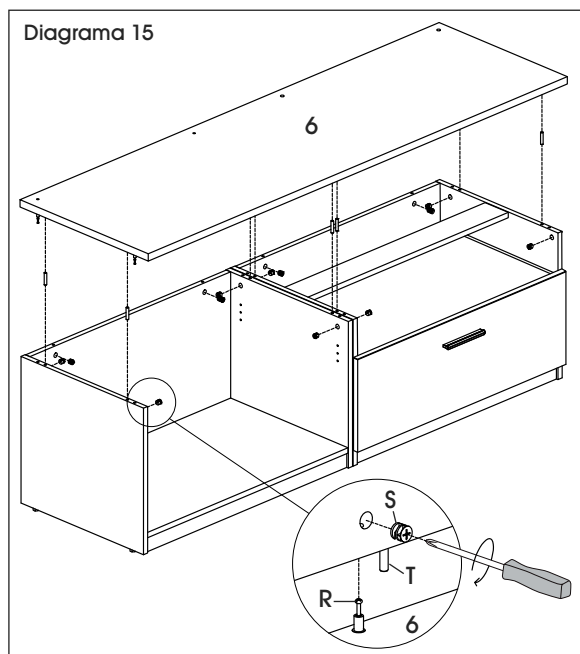

- Vuelva a colocar el cajón superior del archivero lateral inferior.

ENSAMBLE FINAL

- Entre dos personas, coloquen la credenza en el lugar deseado. Levanten cuidadosamente el escritorio básico ensamblado y alinéenlo con la estructura de la pata corta (4) con los orificios correspondientes en el retorno para escritorio (6). Fije la estructura básica al retorno de credenza usando dos pernos M6 x 40 mm (I). (Vea Diagrama 16)

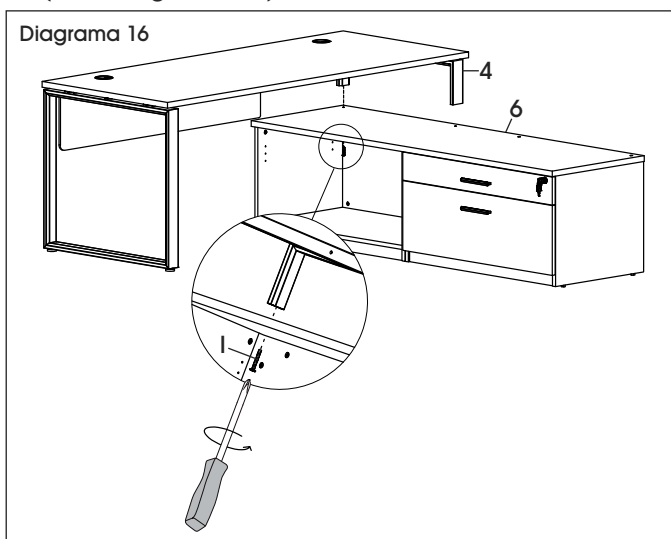

- Inserte los taquetes para repisa (T) en los paneles laterales del librero. Coloque el panel del librero (12) sobre los taquetes de las repisas. Apriete los soportes de las repisas debajo de ellas para un ajuste seguro. (Vea Diagrama 17)

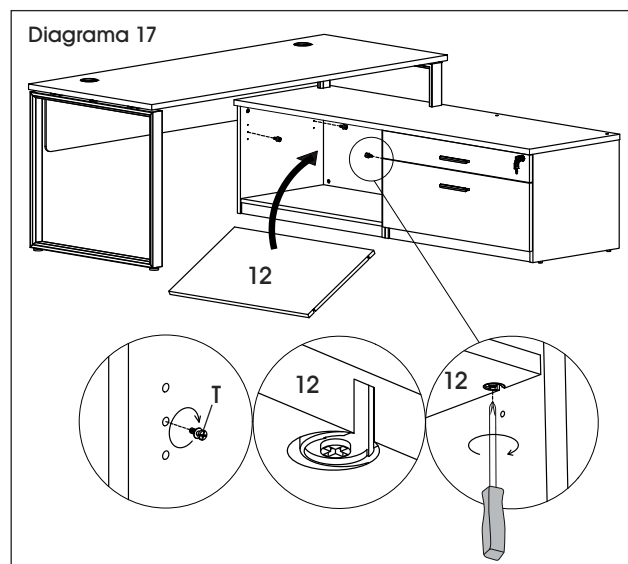

CONTINUACIÓN DEL ENSAMBLE

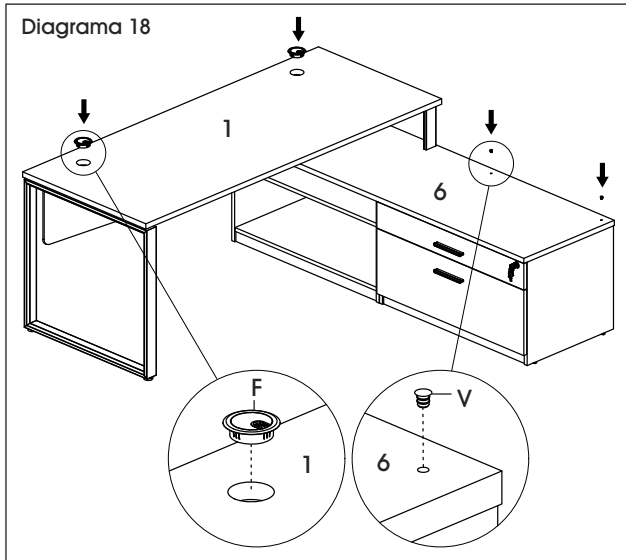

3. Inserte los ojales (F) en el escritorio (1) y las tapas de plástico (V) dentro de los orificios del retorno para escritorio (6). (Vea Diagrama 18)



NOTA: Si se usa el asiento acojinado opcional, no necesitará insertar las tapas de plástico en el retorno para escritorio. El asiento acojinado cubrirá los orificios expuestos.



NOTA: El asiento acojinado se coloca sobre la parte superior de la credenza inferior. Las almohadillas de caucho que están debajo del asiento acojinado la fijarán en su lugar.

ENSAMBLE TERMINADO

Lado Derecho

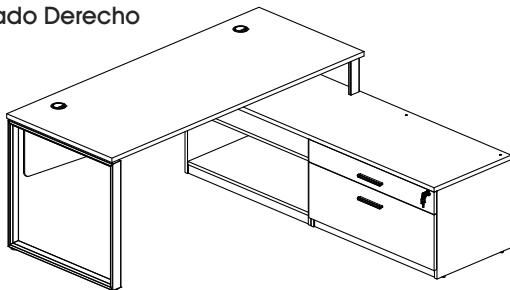

Lado Izquierdo

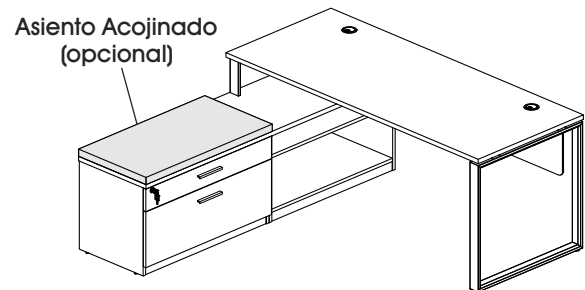
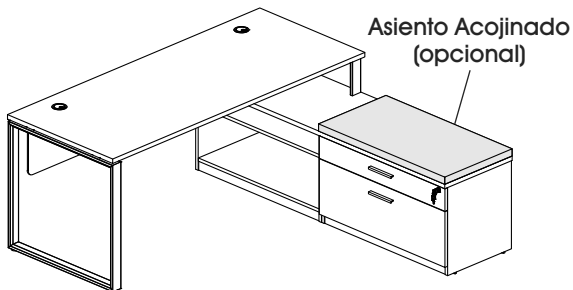
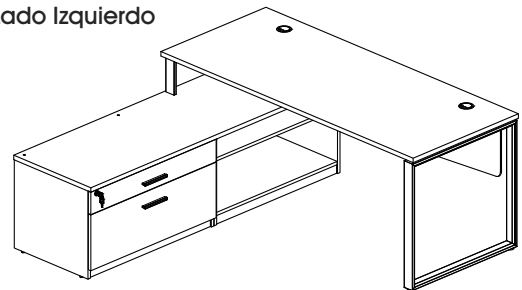

INSTALACIÓN DE LA BARRA PARA CARPETAS

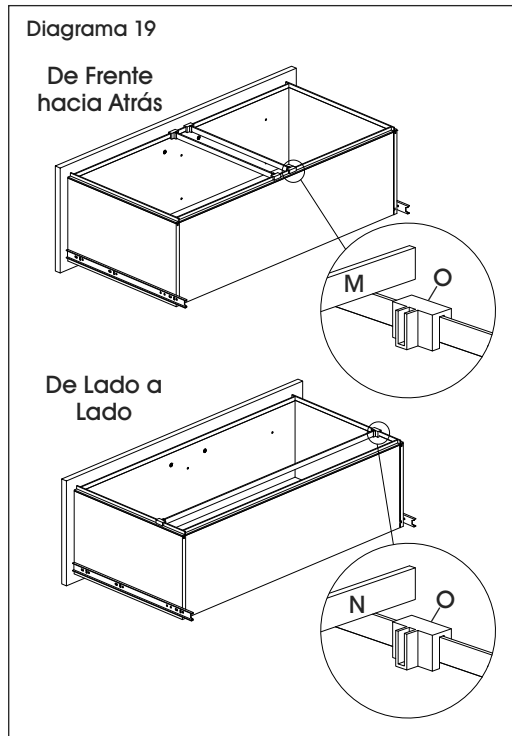

1. Para colgar archivos de frente hacia atrás, fije dos clips de barra (O) a la parte posterior del cajón y dos a la frontal (D). Inserte dos barras cortas para carpetas (M) (Vea Diagrama 19)
2. Para colgar archivos de lado a lado, fije un clip de barra (O) a cada lado del cajón e inserte una barra larga para carpetas (N). (Vea Diagrama 19)

ULINE

800-295-5510
uline.mx

ULINE H-10371

1-800-295-5510

uline.ca

COLLECTION DESIGNER – BUREAU DE RANGEMENT EN L

OUTILS REQUIS

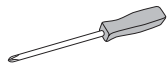

Tournevis cruciforme



Clé Allen
(inclus)



Perceuse
(optionnel)



Montage à deux personnes
recommandé

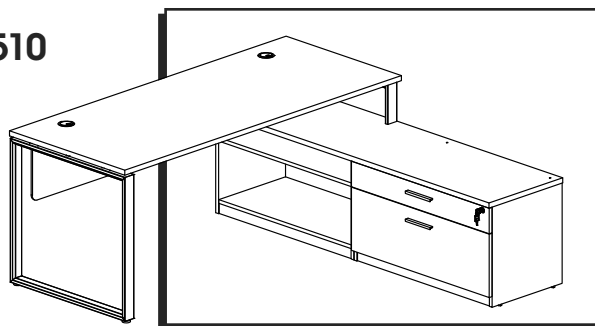

PIÈCES

BUREAU DE BASE

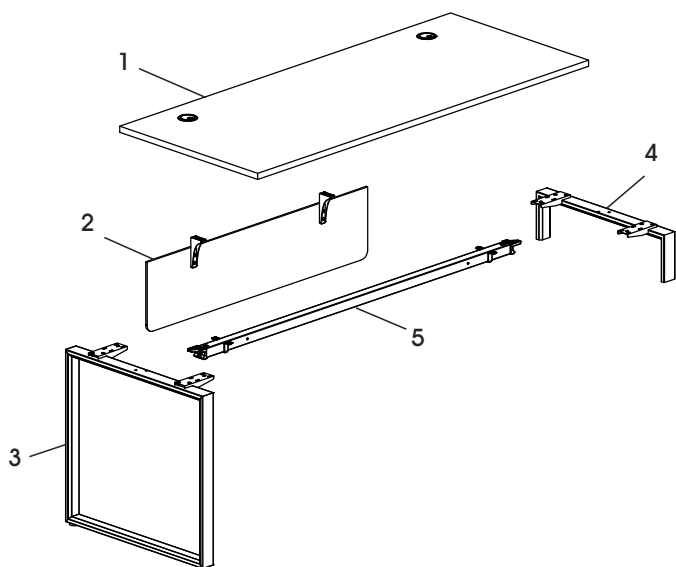

#	DESCRIPTION	QTÉ
1	Surface de bureau	1
2	Panneau cache-jambes	1
3	Cadre de pied	1
4	Cadre de pied court	1
5	Barre de support	1

RETOUR DE BAHUT

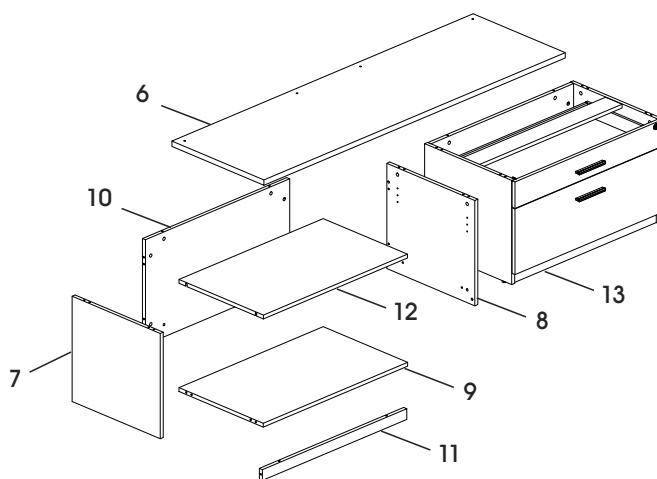

#	DESCRIPTION	QTÉ
6	Surface du retour de bureau	1
7	Panneau latéral gauche	1
8	Panneau latéral droit	1
9	Panneau inférieur	1
10	Panneau arrière	1
11	Panneau de base	1
12	Panneau de bibliothèque	1
13	Classeur latéral bas	1

MATÉRIEL D'INSTALLATION

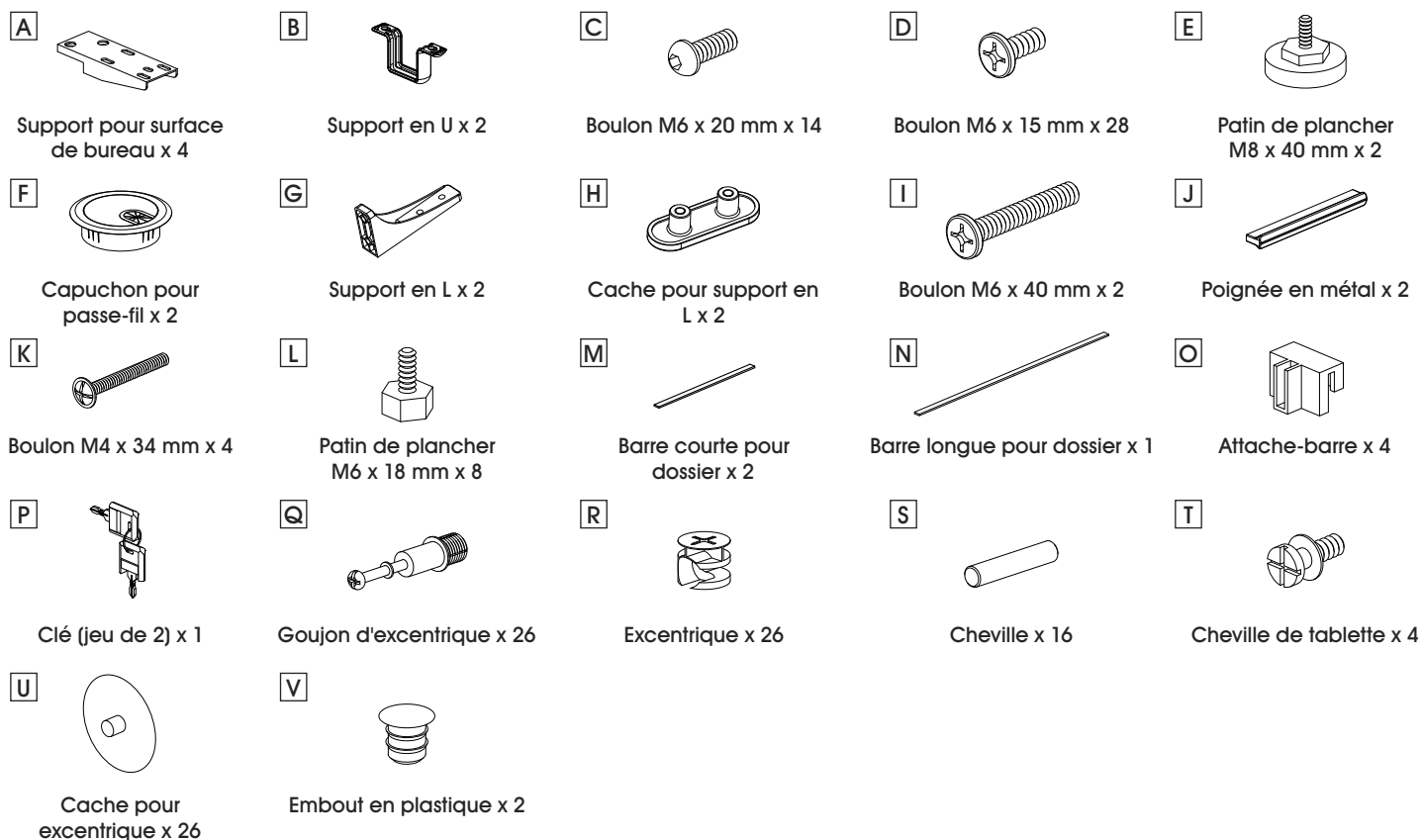

MONTAGE

MONTAGE DU BUREAU DE BASE

1. Installez les patins de plancher M8 x 40 mm (E) sur le cadre de pied (3). Retournez le cadre de pied. (Voir Figure 1)

2. Alignez la barre de support (5) sur les trous du cadre de pied (3) et du cadre de pied court (4) et fixez-la de chaque côté avec trois boulons M6 x 20 mm (C). Serrez le tout avec la clé Allen. (Voir Figure 2)

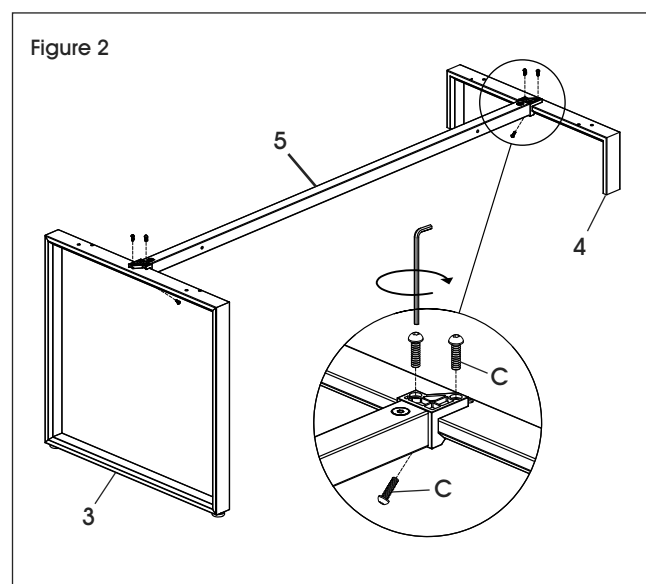
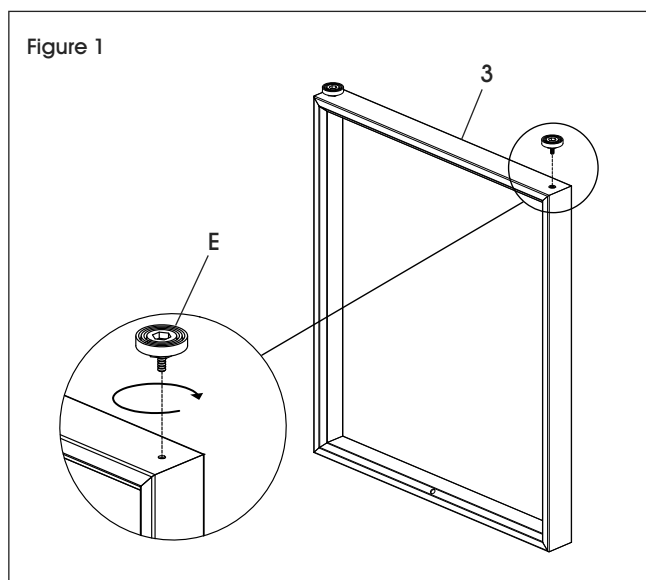

MONTAGE SUITE

3. Fixez quatre supports pour surface de bureau (A) aux cadres de pied (3 et 4) avec deux boulons M6 x 20 mm (C) par support. Serrez le tout avec la clé Allen. (Voir Figure 3)

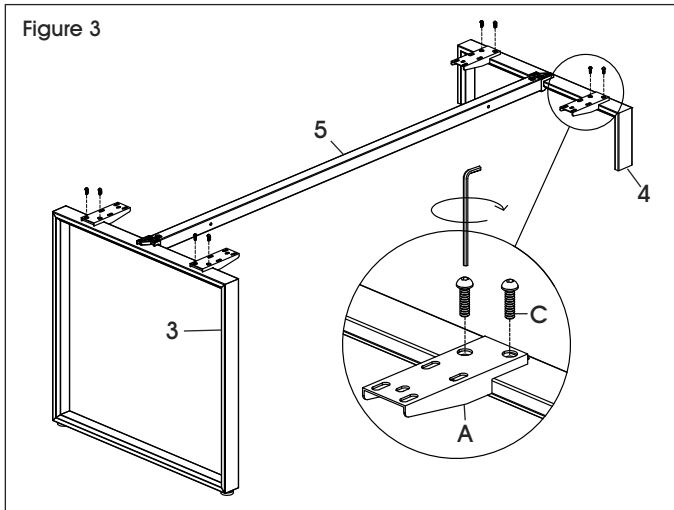

REMARQUE : Déterminez si le bureau en L est configuré à droite ou à gauche. Le montage du bureau de rangement en L avec configuration à droite est indiqué dans les illustrations suivantes. Pour une configuration à gauche, le cadre de pied court est placé sur le côté opposé du bureau.

4. À deux, placez la surface de bureau (1) à l'envers avec les trous vers le haut. Retournez le cadre du bureau assemblé. Fixez chaque support pour surface de bureau (A) à la surface de bureau (1) avec quatre boulons M6 x 15 mm (D). Serrez le tout avec un tournevis cruciforme. (Voir Figure 4)

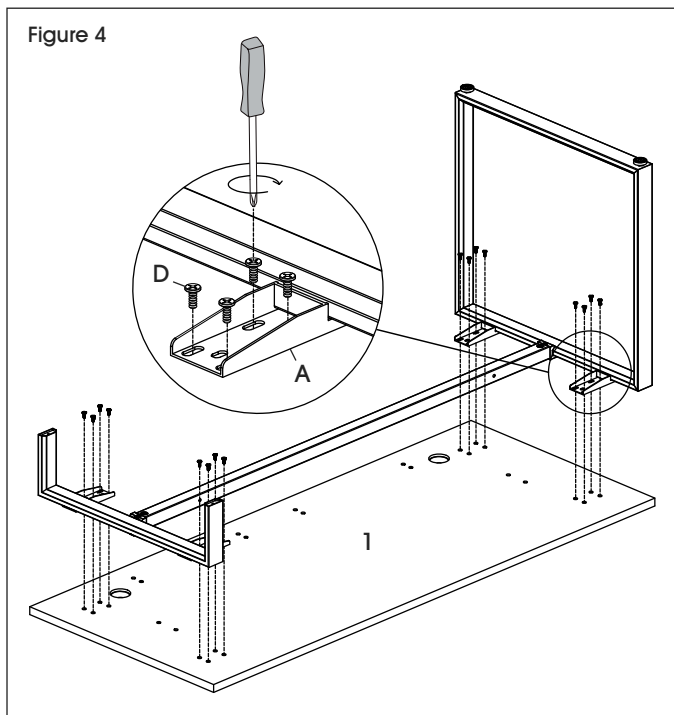

5. Alignez les supports en U (B) sur les trous de la surface de bureau et fixez chaque support avec deux boulons M6 x 15 mm (D). Serrez le tout avec un tournevis cruciforme. (Voir Figure 5)

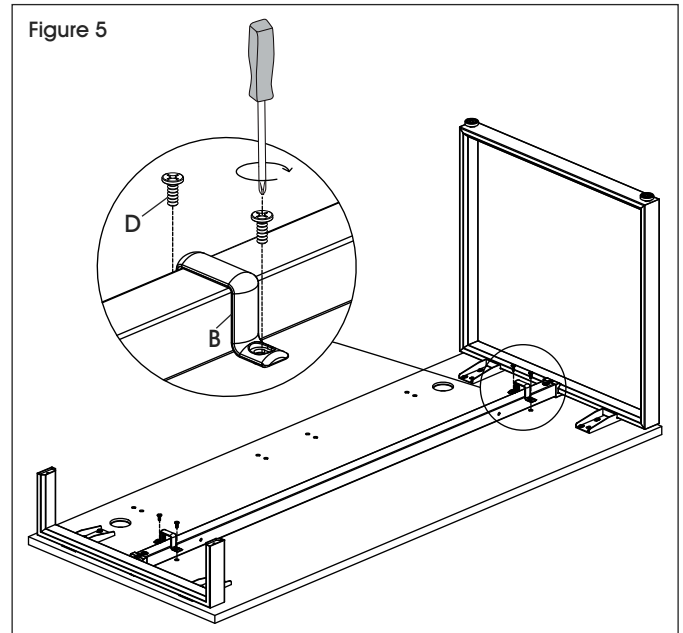

6. Alignez les supports en L (G) et les caches pour support en L (H) sur les trous du panneau cache-jambes (2). Fixez chaque ensemble de support et de cache avec deux boulons M6 x 15 mm (D). Serrez le tout avec un tournevis cruciforme. (Voir Figure 6)

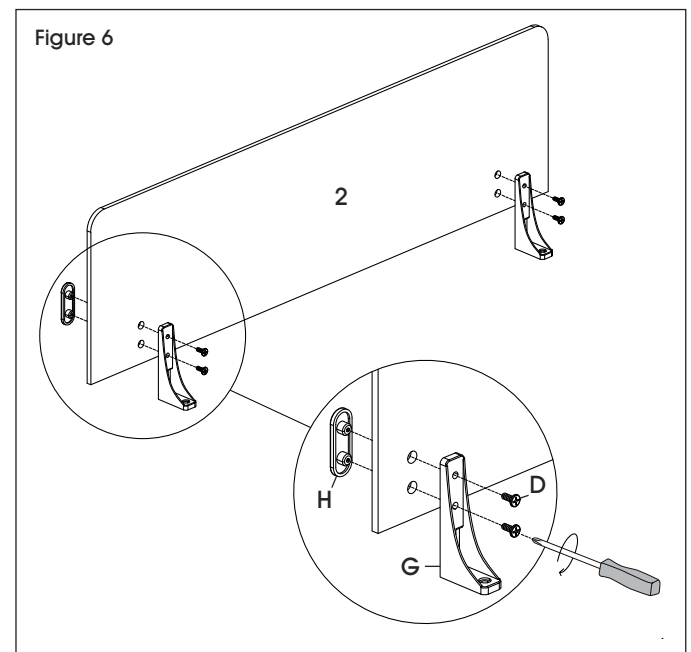

MONTAGE SUITE

- Alignez les supports en L (G) sur les trous de la surface de bureau (1) et fixez chaque support avec deux boulons M6 x 15 mm (D). Serrez le tout avec un tournevis cruciforme. (Voir Figure 7)

 **REMARQUE :** Installez le panneau cache-jambes du côté le plus proche du grand cadre de pied.

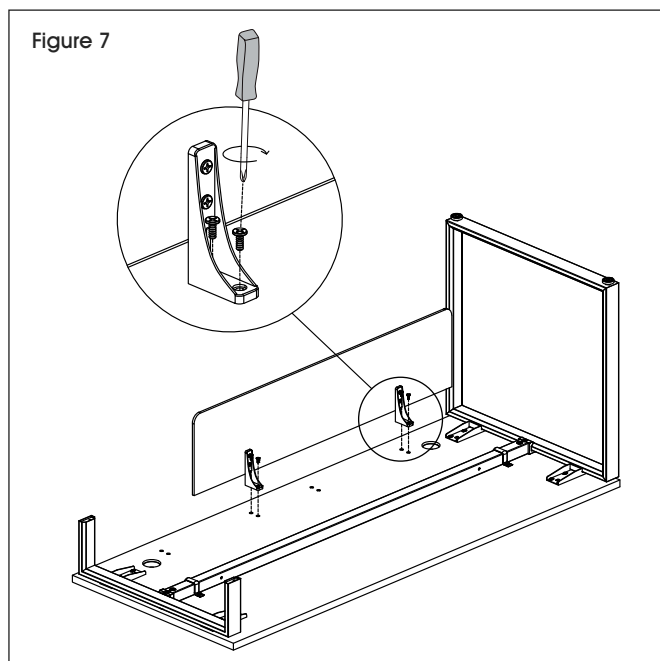

MONTAGE DU RETOUR DE BAHUT

- Verrouillez les tiroirs du classeur latéral bas (13). À deux, posez le classeur sur le côté ou sur le dos.
- Insérez les patins de plancher M6 x 18 mm (L) en dessous du classeur. Les patins peuvent être réglés pour compenser les inégalités des planchers. (Voir Figure 8)

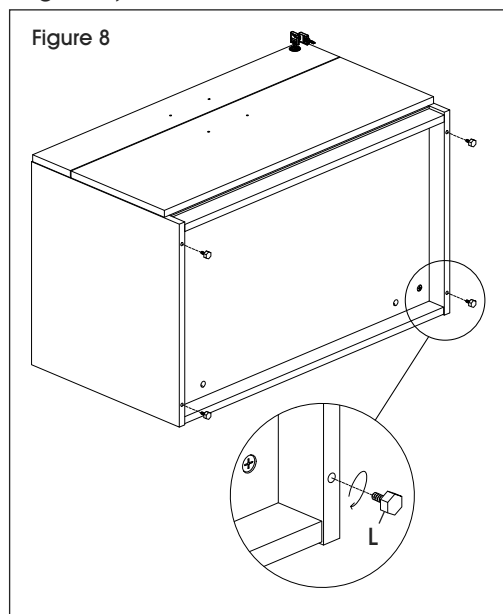

- À deux, posez le classeur à la verticale. Déverrouillez les tiroirs. Retirez la poignée (J) située à l'intérieur du tiroir avec un tournevis cruciforme et fixez-la à l'extérieur du tiroir avec les mêmes vis (K). Répétez l'opération pour le deuxième tiroir. Mettez le classeur de côté. (Voir Figure 9)

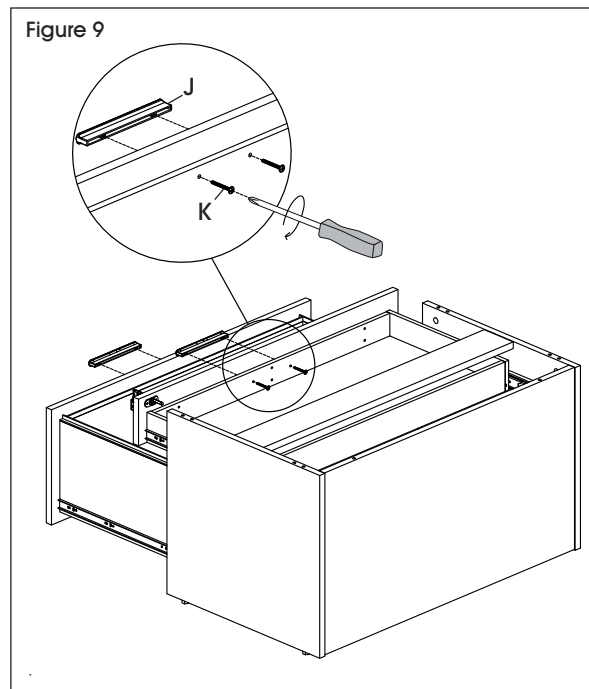

- Commencez l'assemblage de la partie bibliothèque en installant deux goujons d'excentrique (Q) dans le panneau inférieur (9). Insérez deux excentriques (R) dans les trous correspondants du panneau de base (11). Assemblez les panneaux de base et inférieur et tournez l'excentrique dans le sens horaire jusqu'à ce qu'il se verrouille. (Voir Figure 10)

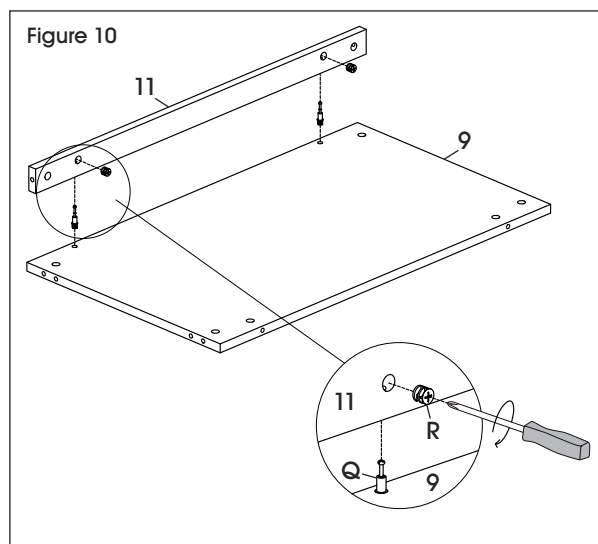

MONTAGE SUITE



IMPORTANT! Tournez l'excentrique (R) de 1/4 de tour vers la droite pour le verrouiller. Vérifiez que la flèche pointe vers le bord du panneau avant de l'insérer dans le trou du panneau.

IMPORTANT : Fonctionnement des excentriques

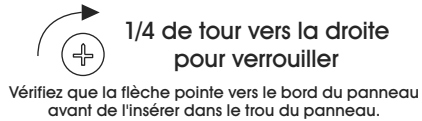

IMPORTANT! Les goujons d'excentrique (Q) doivent être serrés après insertion dans le panneau. Pour les serrer, saisissez la partie inférieure du goujon et serrez avec un tournevis cruciforme.

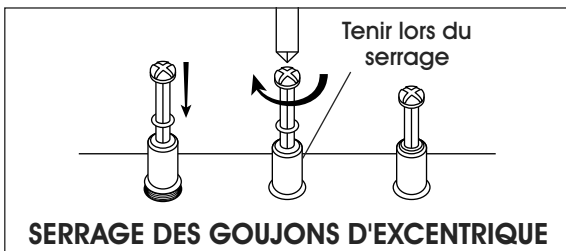

REMARQUE : Une fois les excentriques serrés, les caches pour excentrique (U) peuvent être installés pour donner un aspect fini.

5. Installez deux goujons d'excentrique (Q) dans le panneau arrière (10). Insérez deux excentriques (R) dans les trous correspondants du panneau inférieur (9). Assemblez les panneaux inférieur et arrière et serrez les excentriques. (Voir Figure 11)

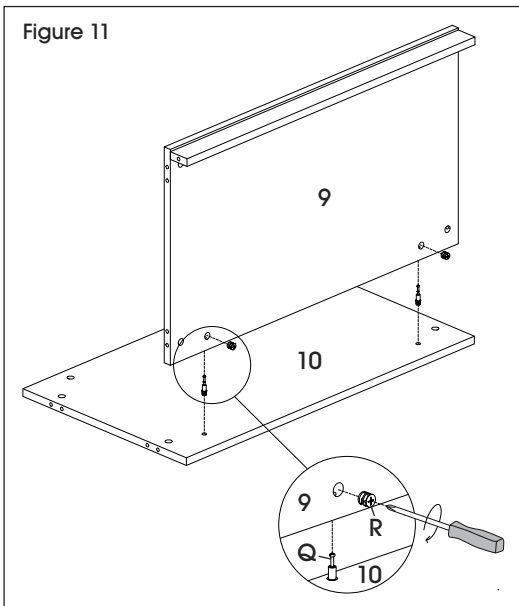

6. Installez cinq goujons d'excentrique (Q) et quatre chevilles (S) dans chaque panneau latéral (7 et 8). Insérez les excentriques (R) dans les trous correspondants du panneau inférieur (9), du panneau arrière (10) et du panneau de base (11). Serrez les excentriques. (Voir Figure 12)
7. Insérez les patins de plancher M6 x 18 mm (L) dans le bord inférieur des panneaux latéraux (7 et 8). Les patins peuvent être réglés pour les planchers inégaux. (Voir Figure 12)

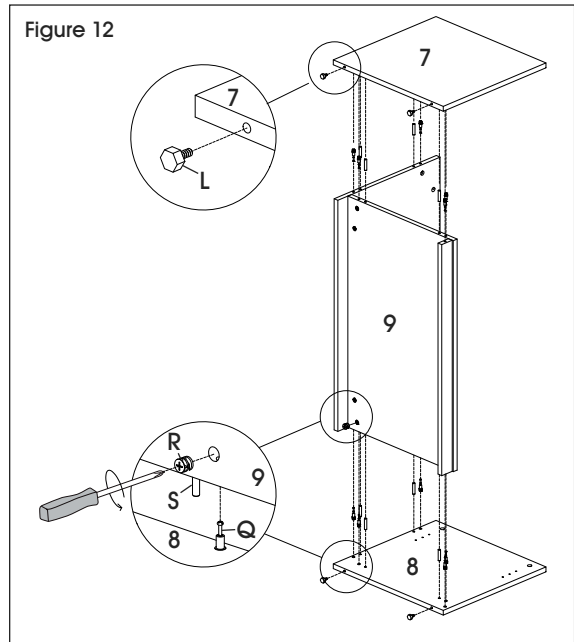

8. À deux, placez la surface du retour de bureau (6) à l'envers avec les trous vers le haut. Installez 12 goujons d'excentrique (Q) dans la surface du retour de bureau. (Voir Figure 13)

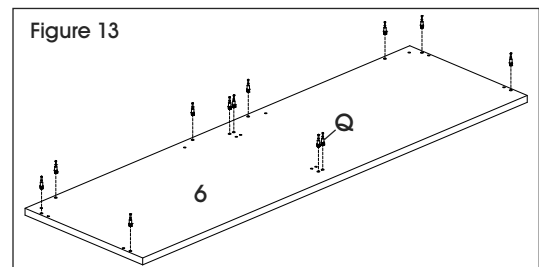

MONTAGE SUITE

9. À deux, tournez la bibliothèque assemblée à la verticale et placez-la à côté du classeur latéral bas (13). Insérez huit chevilles (S) et 12 excentriques (R) dans les bords supérieurs de la bibliothèque et du classeur latéral. (Voir Figure 14)

 **REMARQUE :** Pour une configuration à gauche, placez la bibliothèque à droite du classeur latéral bas.

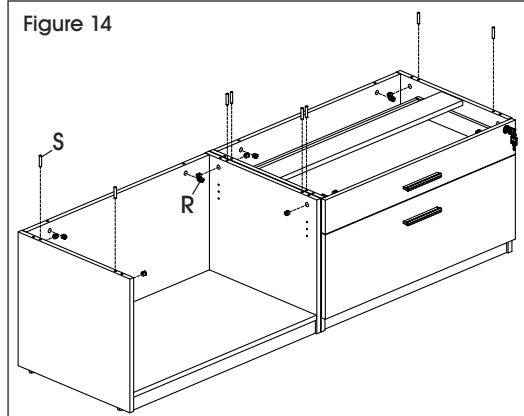

10. Ouvrez le tiroir supérieur du classeur latéral et repérez la languette en plastique se trouvant sur les coulisses du tiroir. Poussez vers le haut sur une languette et vers le bas sur la languette du côté opposé pour libérer et sortir le tiroir.
11. À deux, retournez la surface du retour de bureau (6) et fixez-la à la bibliothèque et au classeur latéral (13). Serrez les excentriques. (Voir Figure 15)

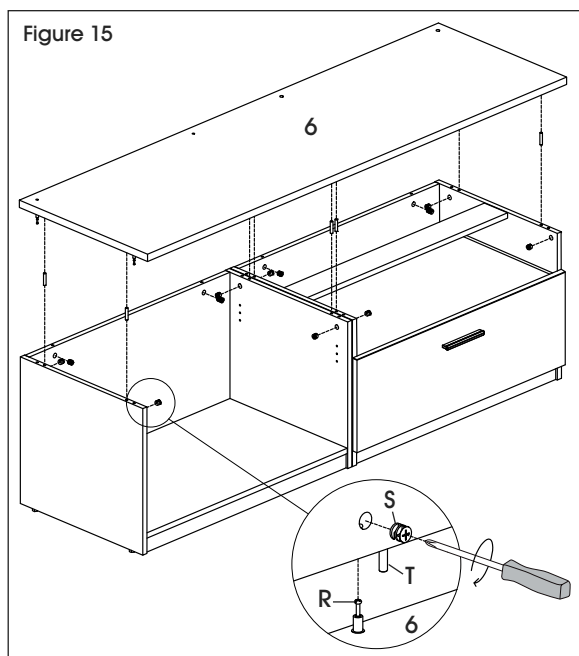

12. Remplacez le tiroir supérieur du classeur latéral bas.

MONTAGE FINAL

1. À deux, placez le retour de bahut à l'emplacement souhaité. Soulevez avec précaution le bureau de base assemblé et alignez son cadre de pied court (4) sur les trous correspondants de la surface du retour de bureau (6). Fixez le cadre du bureau de base au retour de bahut avec deux boulons M6 x 40 mm (I). (Voir Figure 16)

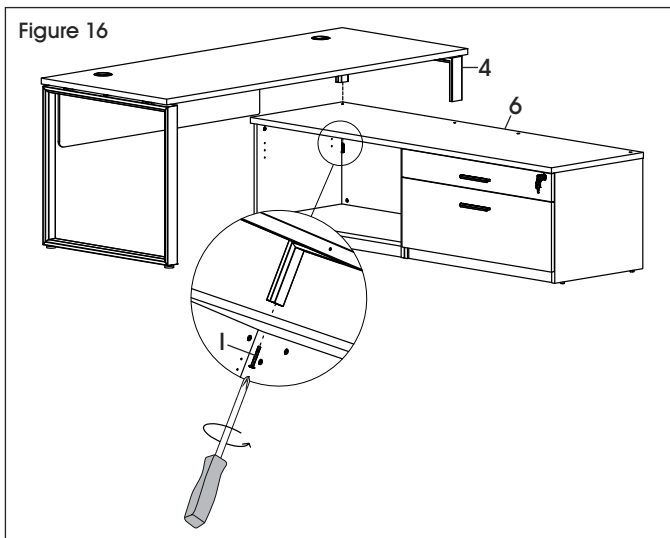

2. Insérez des chevilles de tablette (T) dans les panneaux latéraux de la bibliothèque. Placez le panneau de bibliothèque (12) sur les chevilles de tablette. Serrez les supports de tablette situés sur la face inférieure des tablettes pour bien les ajuster. (Voir Figure 17)

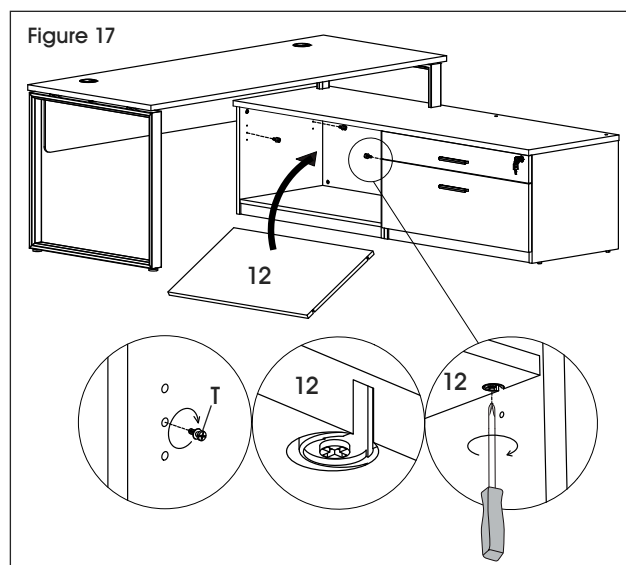

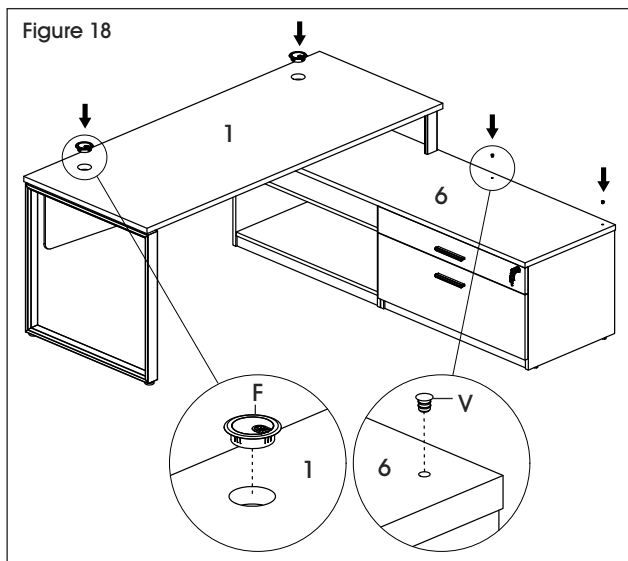

MONTAGE SUITE

Figure 18



3. Insérez les capuchons pour passe-fil (F) dans la surface de bureau (1) et les embouts en plastique (V) dans les trous de la surface du retour de bureau (6). (Voir Figure 18)

 **REMARQUE :** Il n'est pas nécessaire d'insérer les embouts en plastique dans la surface du retour de bureau si vous utilisez le siège en option. Les trous apparents sont couverts par le siège.

 **REMARQUE :** Le siège se place sur le dessus du classeur latéral bas. Les coussinets en caoutchouc qui se trouvent en dessous du siège servent à le maintenir en place.

MONTAGE COMPLÉTÉ

Côté droit

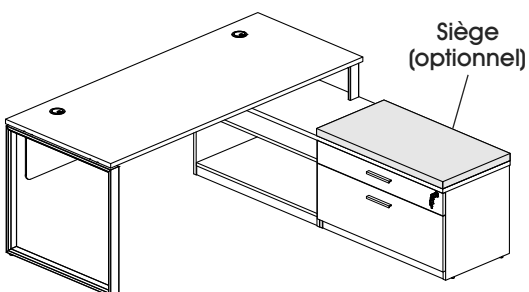
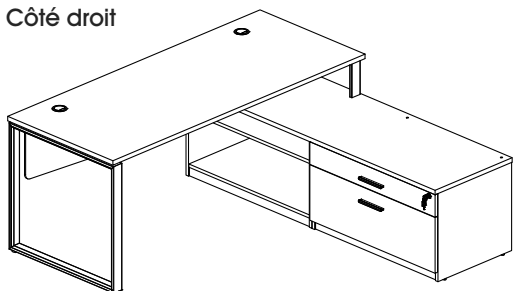

Côté gauche

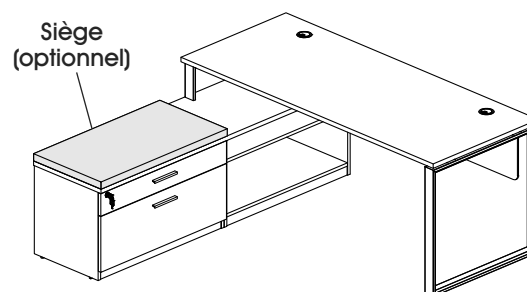
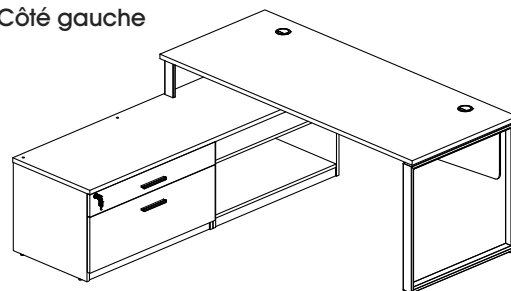

INSTALLATION DES BARRES POUR DOSSIER

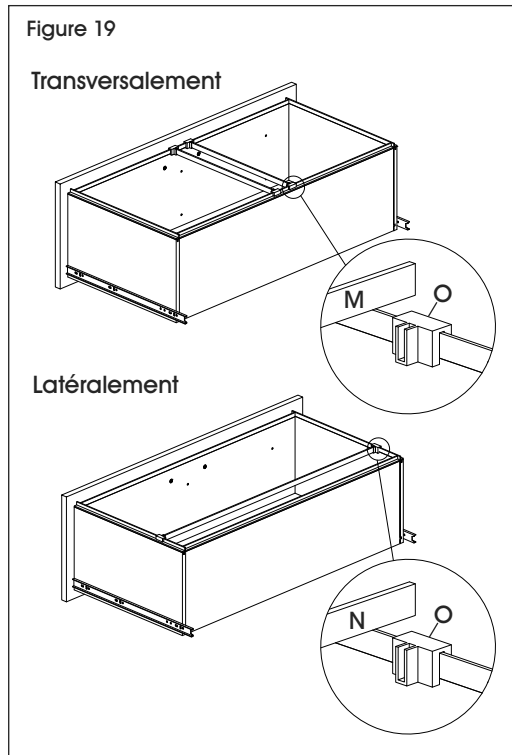

1. Pour suspendre les dossiers transversalement, fixez deux attache-barres (O) à l'arrière du tiroir et deux à l'avant du tiroir. Insérez deux barres courtes pour dossier (M). (Voir Figure 19)
2. Pour suspendre les dossiers latéralement, fixez une attache-barre (O) de chaque côté du tiroir et insérez une longue barre pour dossier (N). (Voir Figure 19)

ULINE

1-800-295-5510
uline.ca