

ULINE H-10415 GLASS DRY ERASE PARTITION

1-800-295-5510
uline.com

TOOL NEEDED

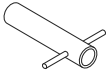

Wrench
(included)



Two Person Assembly
Required

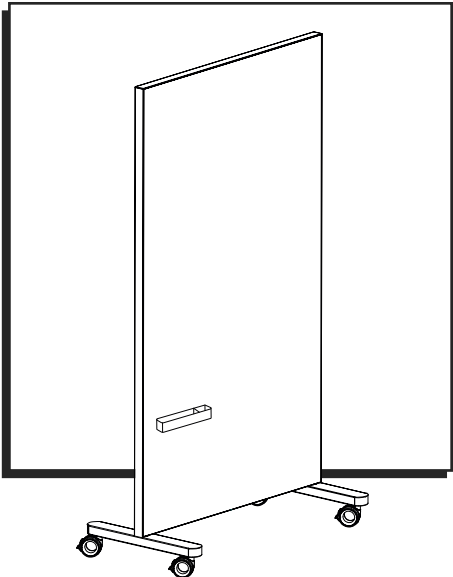

PARTS

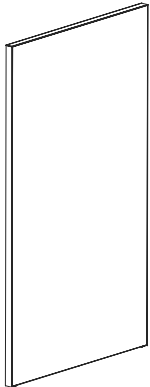

Glass Board x 1

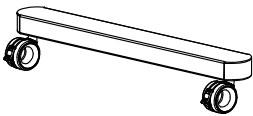

Base x 2



Double-Sided Tape
x 4



Flange Bolt x 4

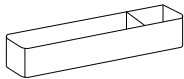

Caddy x 1

ASSEMBLY

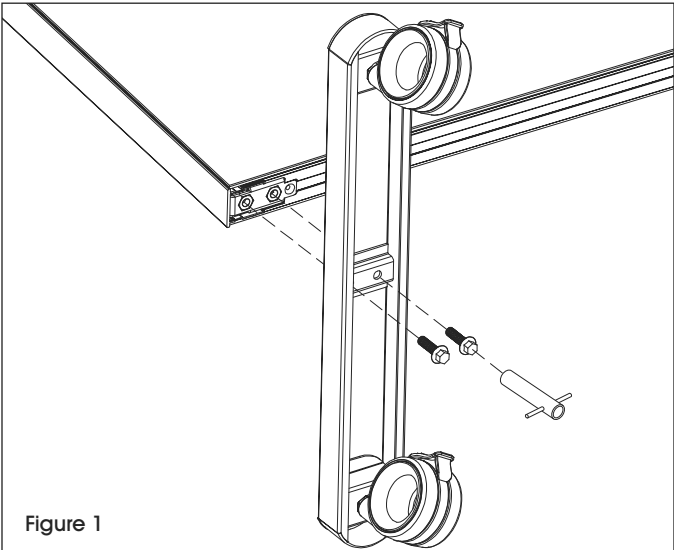

Figure 1



WARNING! Glass dry erase boards are made of safety glass, but improper handling and installation may cause serious injury if the board shatters. Proper installation will require at least two people.

1. Lay board on its side with second person holding it in place.
2. Align base perpendicular to board and ensure that holes on base align with holes on board. Insert two flange bolts and tighten using wrench. (See Figure 1)
3. Repeat step 2 with remaining base and flange bolts on opposite side of board.
4. Return partition to a standing position.

ASSEMBLY CONTINUED

5. Peel off paper back from double-sided tape. Attach tape to back of caddy. (See Figure 2)

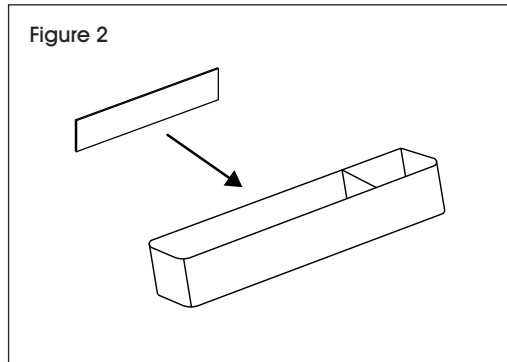

6. Firmly press caddy onto board in desired location. (See Figure 3)

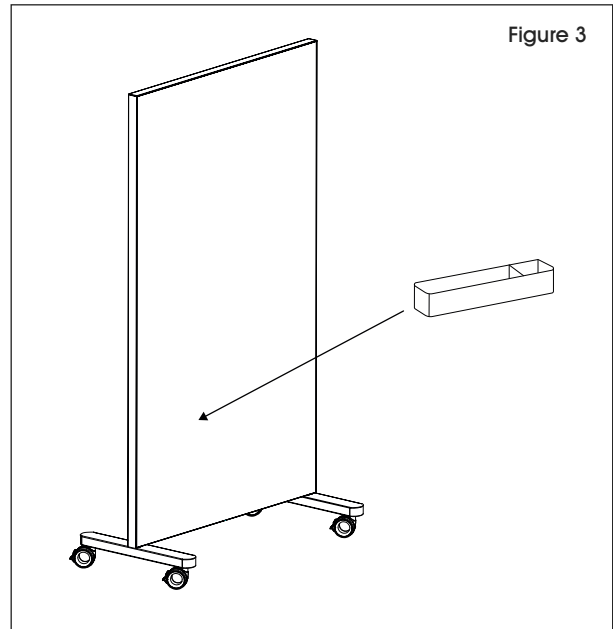

ULINE H-10415

PANEL SEPARADOR CON PIZARRÓN DE CRISTAL

800-295-5510

uline.mx

HERRAMIENTA NECESARIA

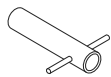

Llave
(incluida)



Se Requiere Armar
Entre Dos Personas

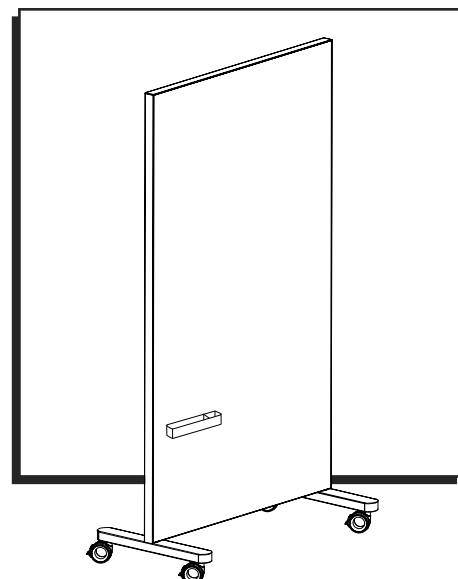

PARTES

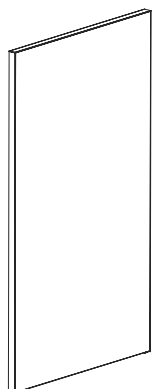

1 Pizarrón de Cristal

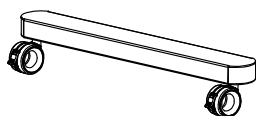

2 Bases



4 Cintas Doble Cara



4 Pernos de Reborde



1 Contenedor

ENSAMBLE



Diagrama 1



iADVERTENCIA! Los pizarrones blancos de cristal están hechos de cristal de seguridad, pero si se maltratan o instalan de manera inapropiada pueden causar lesiones serias si el pizarrón se estrella. Se requieren al menos dos personas para instalar el pizarrón de manera adecuada.

1. Apoye el pizarrón sobre uno de los lados mientras otra persona lo sostiene en su lugar.
2. Alinee la base de forma perpendicular al pizarrón y asegúrese de que los orificios de la base se alineen con los del pizarrón. Inserte dos pernos de reborde y apriételos usando la llave. (Vea Diagrama 1)
3. Repita el paso 2 con la base restante y los pernos de reborde del lado opuesto del pizarrón.

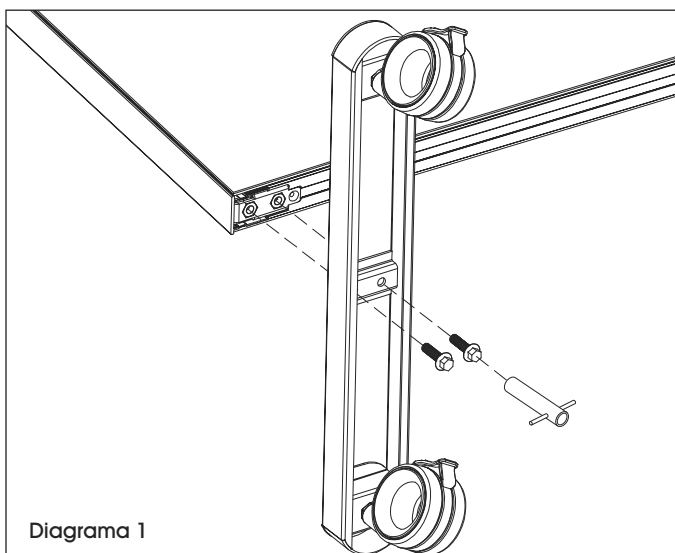
CONTINUACIÓN DEL ENSAMBLE

4. Vuelva a colocar el panel separador en posición vertical.
5. Despegue el respaldo de papel de la cinta doble cara. Fije la cinta a la parte posterior del contenedor. (Vea Diagrama 2)
6. Presione firmemente el contenedor contra el pizarrón en la ubicación deseada. (Vea Diagrama 3)

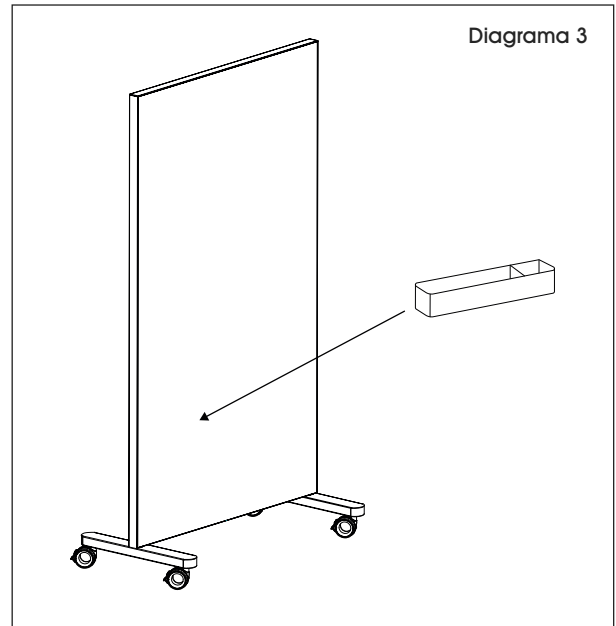
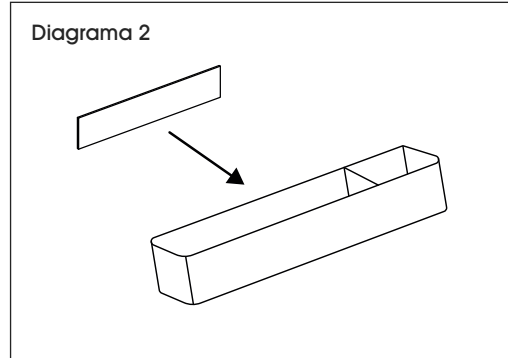

ULINE H-10415

CLOISON EFFAÇABLE À SEC EN VERRE

1-800-295-5510

uline.ca

OUTIL REQUIS

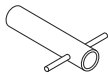

Clé
(inclus)



Montage à deux
personnes requis

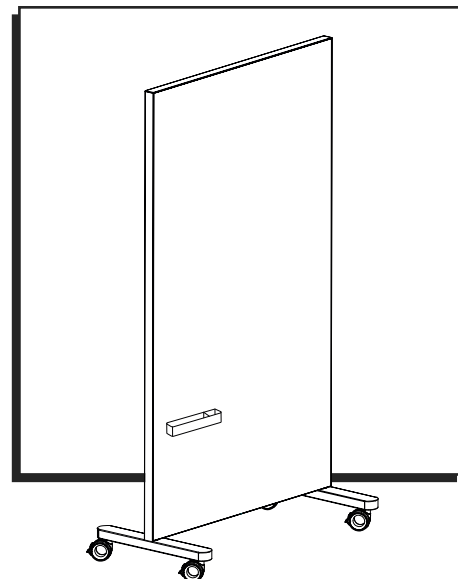

PIÈCES



Tableau en verre x 1



Base x 2

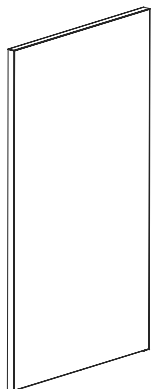
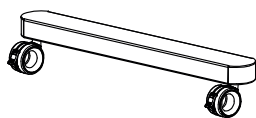

Ruban adhésif
double face x 4



Boulon de bride x 4



Bac x 1

MONTAGE

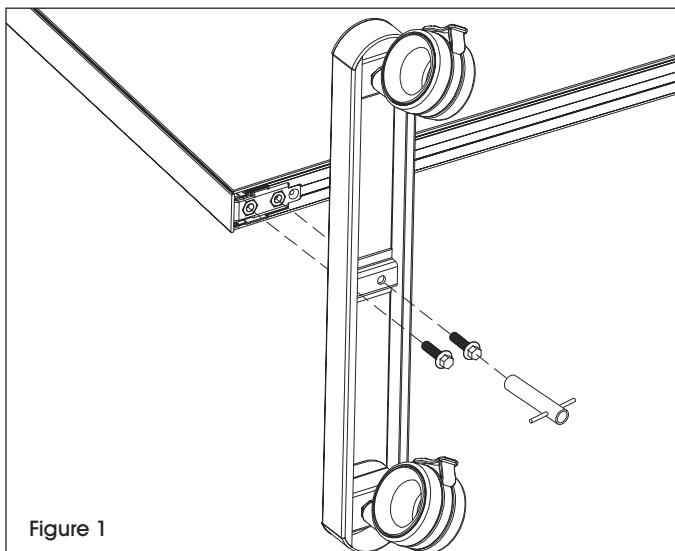

Figure 1



AVERTISSEMENT! Les tableaux effaçables à sec en verre sont fabriqués en verre de sécurité, mais un maniement et une installation inappropriés peuvent entraîner des blessures graves en cas de brisure du tableau. Une installation adéquate nécessite au moins deux personnes.

1. Placez le tableau sur le côté tandis que la deuxième personne le maintient en place.
2. Alignez la base perpendiculairement au tableau et assurez-vous que les trous de la base sont alignés sur les trous du tableau. Insérez deux boulons de bride et serrez-les avec la clé. (Voir Figure 1)
3. Répétez l'étape 2 sur le côté opposé du tableau pour l'autre base et les boulons de bride restants.

MONTAGE SUITE

- Placez la cloison à la verticale.
- Retirez la doublure de papier du ruban adhésif double face. Collez le ruban adhésif sur le dos du bac. (Voir Figure 2)

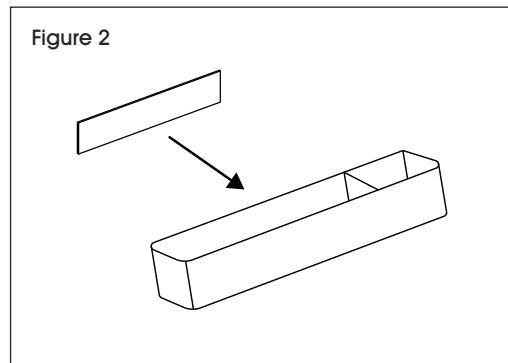

- Appuyez fermement le bac sur le tableau à l'endroit désiré. (Voir Figure 3)

