

ULINE H-1044, H-1063

1-800-295-5510
uline.com

RUBBERMAID® FLAT SHELF CART WITH FLAT HANDLE

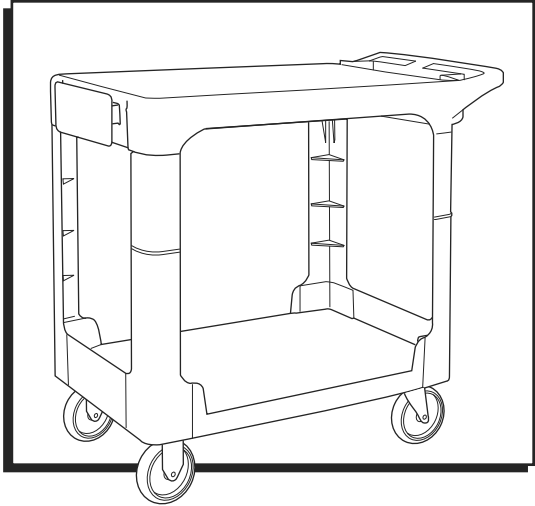

TOOLS NEEDED

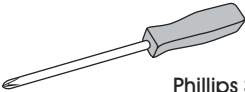

Phillips Screwdriver



Rubber Mallet

PARTS



Swivel Caster x 2



Rigid Caster x 2

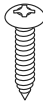

Screw x 20

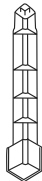

Support x 4

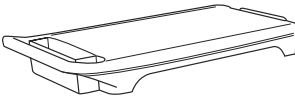

Top Shelf x 1

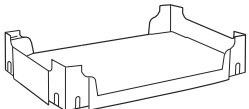

Bottom Shelf x 1

ASSEMBLY

1. Lay bottom shelf upside down on table with one shelf end hanging over the edge of table.
2. Place one support on each corner over edge. (See Figure 1)
3. Position a rigid caster over the bolt holes of each support. (See Figure 2)
4. Screw each caster into the underside of the bottom shelf using four screws.

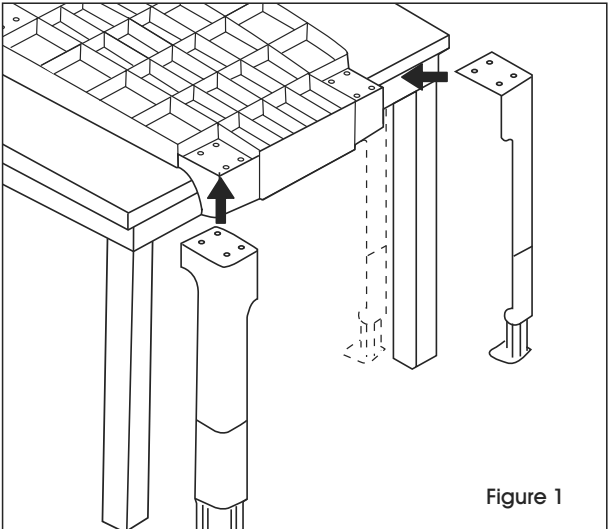

Figure 1

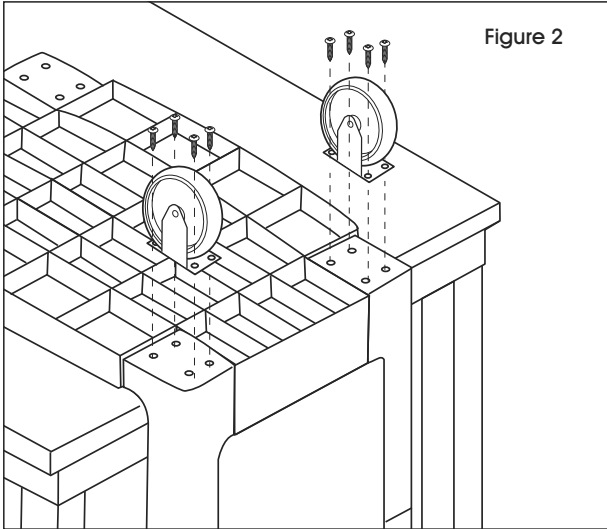

Figure 2

ASSEMBLY CONTINUED

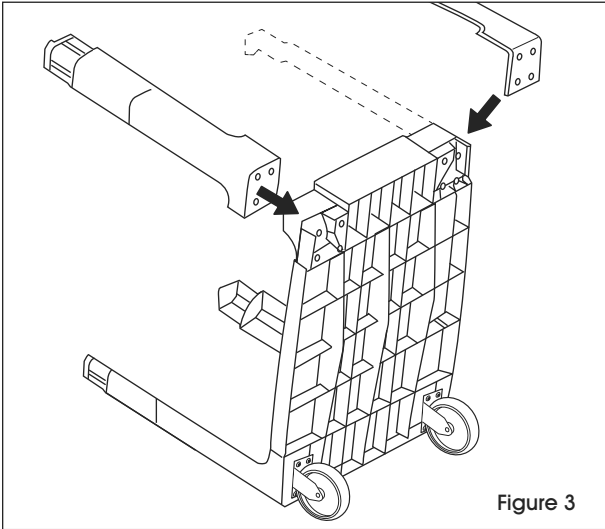

Figure 3

5. Turn the cart on its side so the supports are laying on the ground. (See Figure 3)
6. Attach remaining supports to corners.

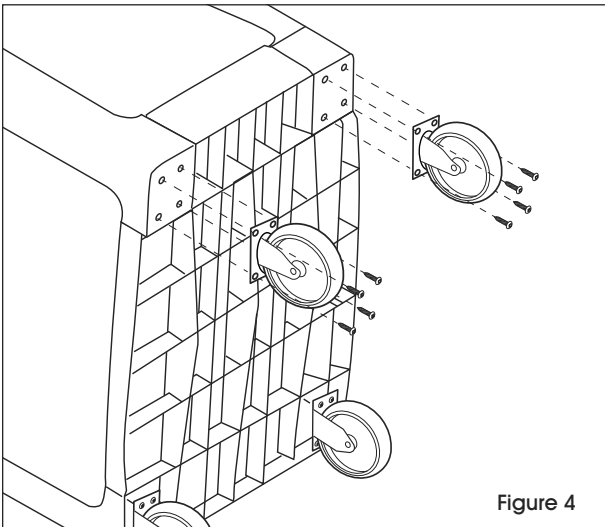

Figure 4

7. Screw swivel casters into the underside of the bottom shelf using four screws. (See Figure 4)

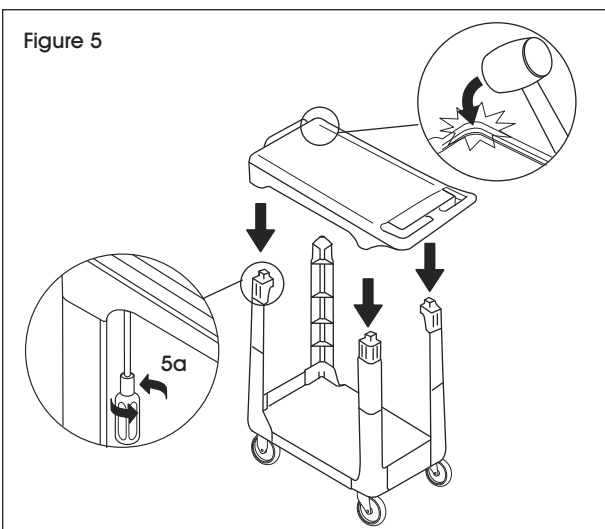



Figure 5

8. Turn cart upright so casters are on the ground and supports are vertical. (See Figure 5)
9. Position top shelf on top of supports.
 **NOTE:** Handle should be above swivel casters.
10. Tap top shelf onto supports using rubber mallet.
11. Screw supports into top shelf using four screws. (See Figure 5a)

ULINE

1-800-295-5510
uline.com

ULINE H-1044, H-1063

800-295-5510

uline.mx

RUBBERMAID® CARRITO CON REPISA PLANA Y ASA PLANA

HERRAMIENTAS NECESARIAS

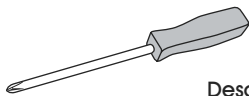

Desarmador
Phillips



Mazo de caucho

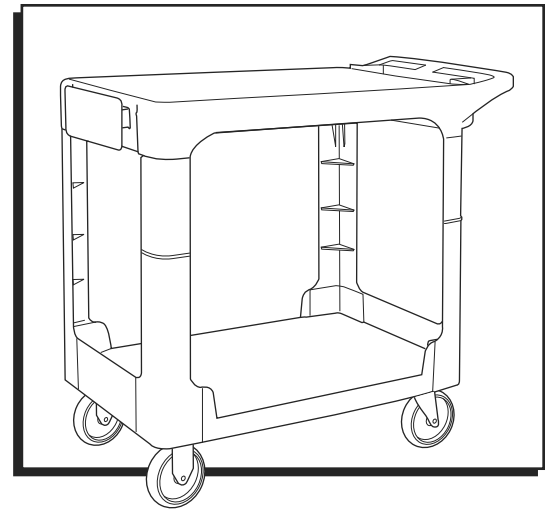

PARTES

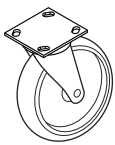

2 Ruedas
Giratorias



2 Ruedas Fijas

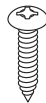

20 Tornillos

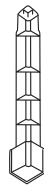

4 Soportes

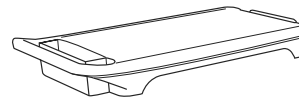

1 Repisa
Superior

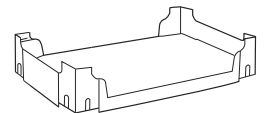

1 Repisa Inferior

ENSAMBLE

1. Coloque la repisa inferior boca abajo sobre una mesa con uno de los extremos de la repisa colgando sobre el borde de la mesa.
2. Coloque un soporte sobre el borde de cada esquina. (Vea Diagrama 1)
3. Coloque una rueda fija sobre los orificios para pernos de cada uno de los soportes. (Vea Diagrama 2)
4. Atornille cada una de las ruedas a la parte de abajo de la repisa inferior usando cuatro tornillos.

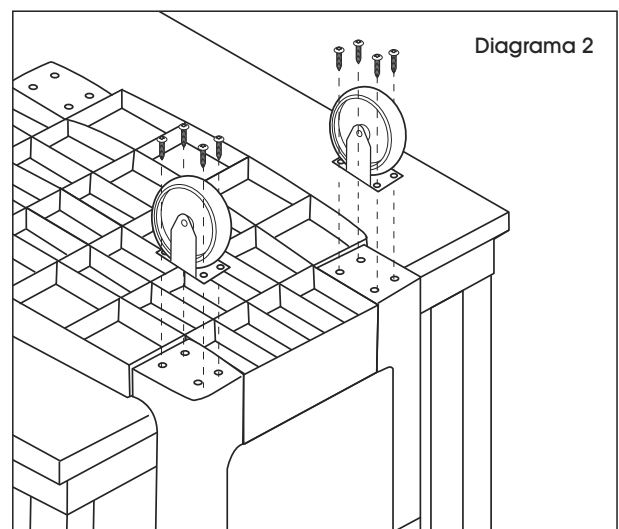
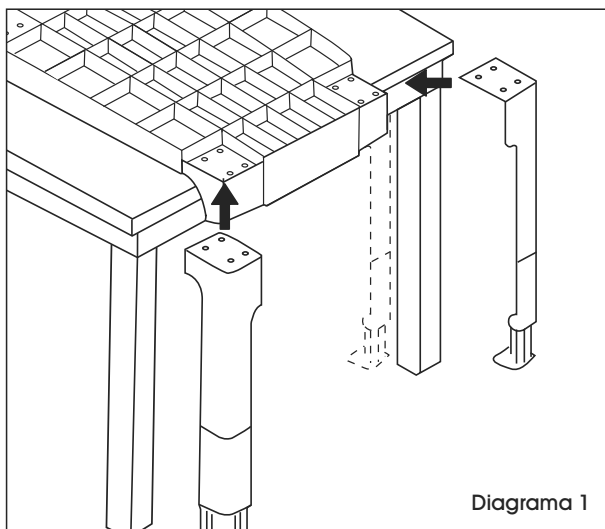

CONTINUACIÓN DE ENSAMBLE

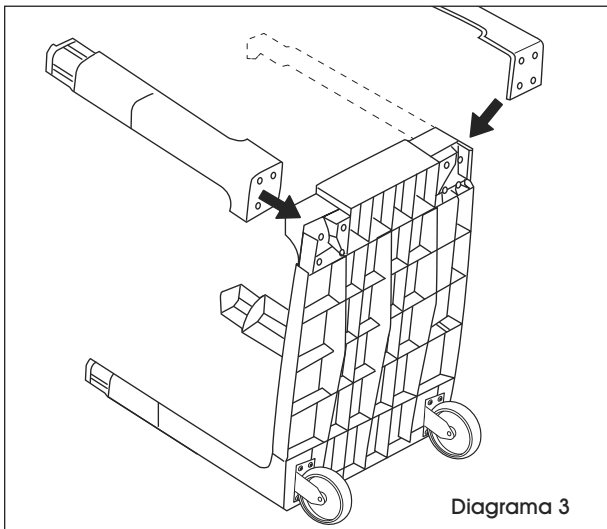

5. Coloque el carrito de lado, de forma que los soportes se apoyen en el piso. (Vea Diagrama 3)
6. Fije a las esquinas el resto de los soportes.

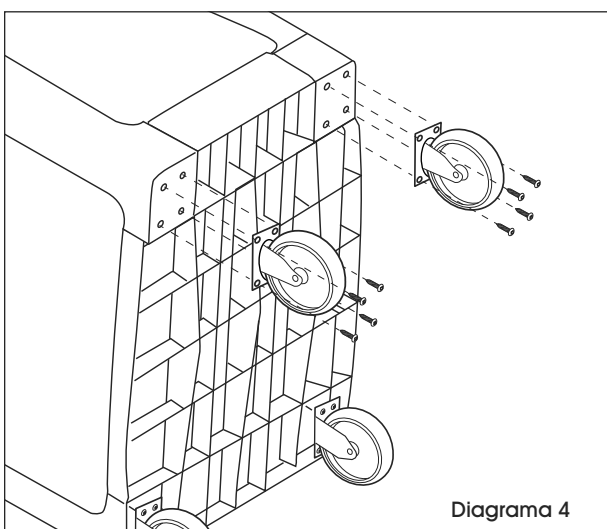

7. Atornille las ruedas giratorias a la parte de abajo de la repisa inferior usando cuatro tornillos. (Vea Diagrama 4)

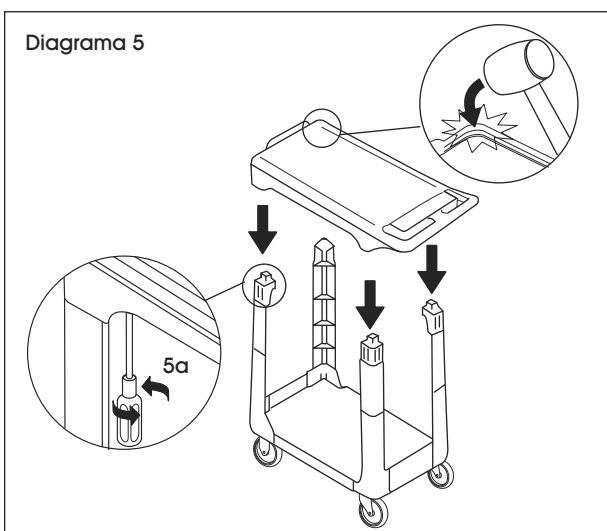

8. Voltee el carrito para colocarlo en posición vertical de forma que las ruedas descansen sobre el suelo y los soportes queden verticales. (Vea Diagrama 5)
9. Coloque la repisa superior sobre los soportes.
 **NOTA:** El asa debe quedar sobre las ruedas giratorias.
10. Golpee ligeramente la repisa superior en los soportes usando un mazo de caucho.
11. Atornille los soportes a la repisa superior usando cuatro tornillos. (Vea Diagrama 5a)

ULINE

800-295-5510

uline.mx

ULINE H-1044, H-1063

RUBBERMAIDMD.

CHARIOT À TABLETTE ET POIGNÉE PLATES

1-800-295-5510

uline.ca

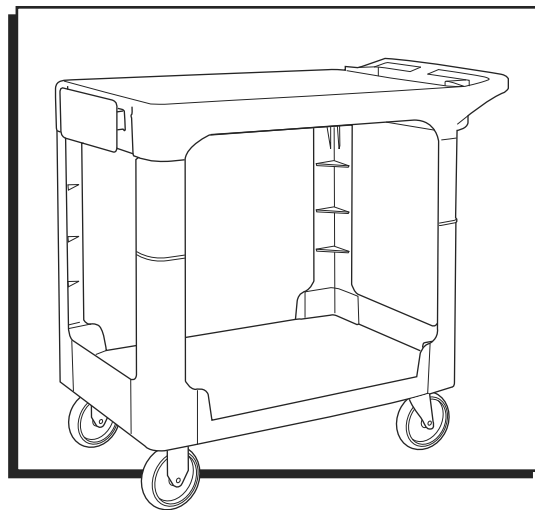

OUTILS REQUIS

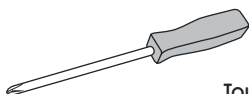

Tournevis
cruziforme



Mallet en
caoutchouc

PIÈCES



Roulette
pivotante x 2

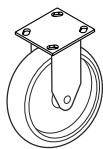

Roulette rigide x 2

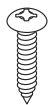

Vis x 20

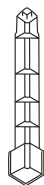

Support x 4

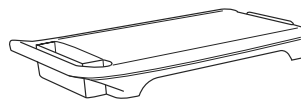

Tablette
supérieure x 1



Tablette inférieure
x 1

MONTAGE

1. Déposez la tablette inférieure à l'envers sur la table en laissant dépasser une extrémité de la tablette du bord de la table.
2. Placez un support sur chaque coin, par-dessus le bord. (Voir Figure 1)
3. Placez une roulette rigide sur les trous de boulon de chaque support. (Voir Figure 2)
4. Vissez chaque roulette dans le dessous de la tablette inférieure à l'aide de quatre vis.

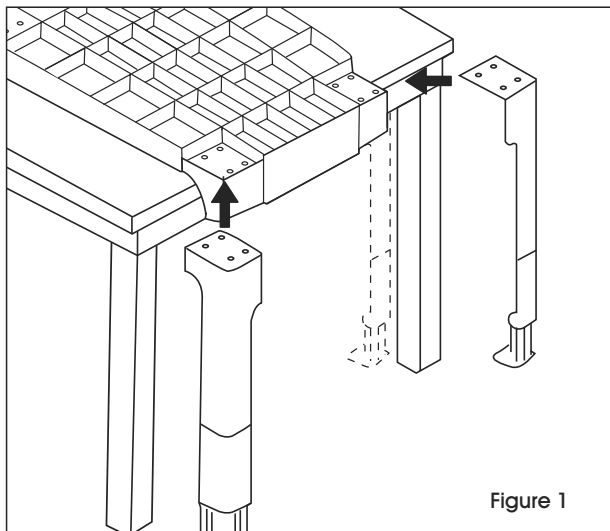

Figure 1

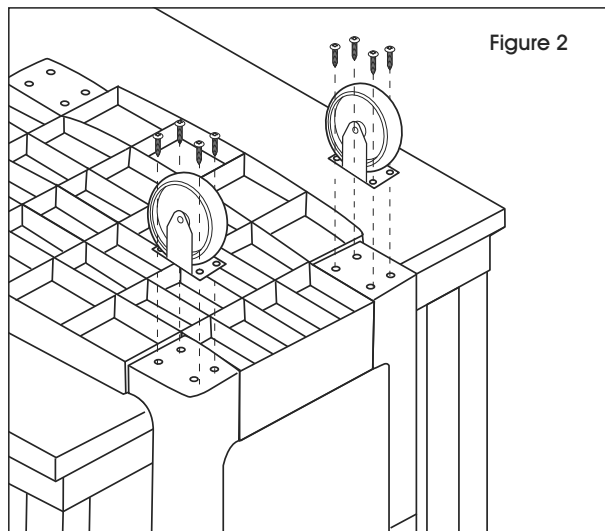
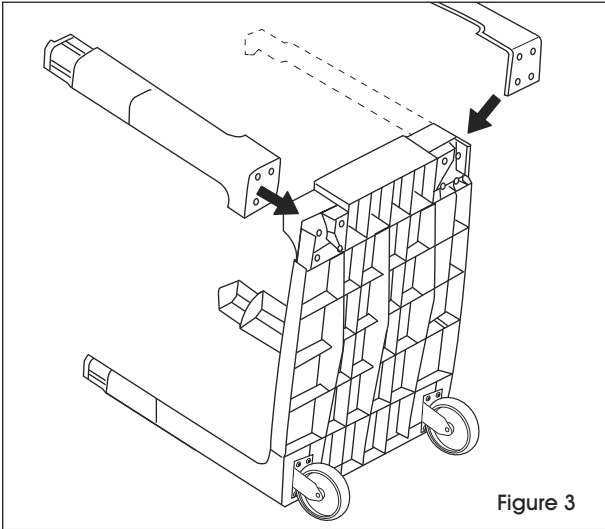
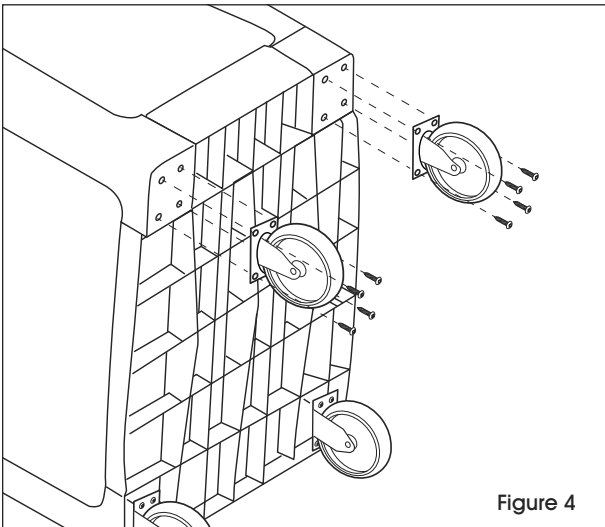

Figure 2

MONTAGE SUITE



5. Tournez le chariot sur le côté de façon à ce que les supports soient appuyés au sol. (Voir Figure 3)
6. Fixez les supports restants aux coins.



7. Vissez les roulettes pivotantes dans le dessous de la tablette inférieure à l'aide de quatre vis. (Voir Figure 4)

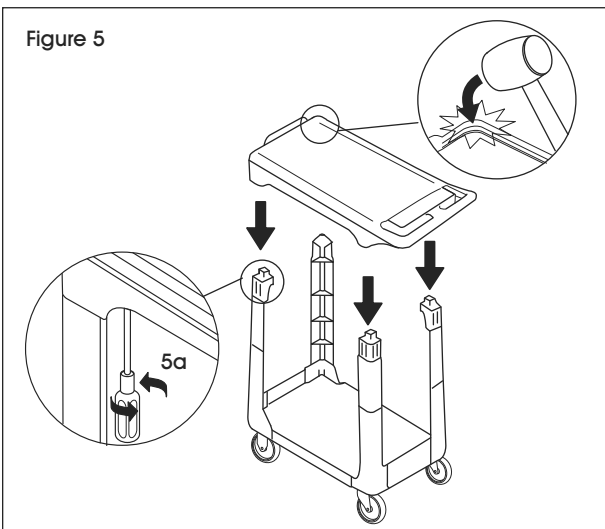

8. Retournez le chariot de façon à ce que les roulettes reposent sur le sol et que les supports soient à la verticale. (Voir Figure 5)
 9. Placez la tablette supérieure sur les supports.
-  **REMARQUE :** La poignée doit se trouver au-dessus des roulettes pivotantes.
10. Insérez la tablette supérieure dans les supports à l'aide d'un maillet en caoutchouc.
 11. Vissez les supports dans la tablette supérieure à l'aide de quatre vis. (Voir Figure 5a)

ULINE

1-800-295-5510
uline.ca