

**ULINE** H-10616, H-10617  
**HEAVY DUTY  
 EXPORT PALLET**

1-800-295-5510  
 uline.com

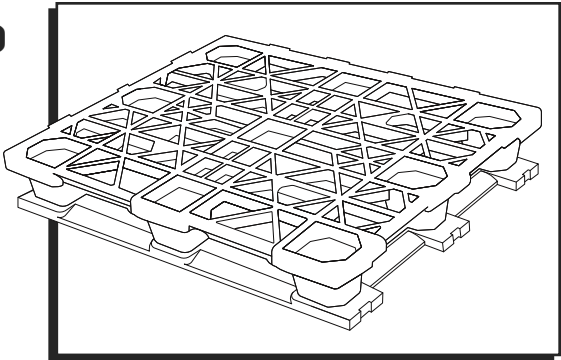

**PRODUCT DIMENSIONS**

TOP VIEW

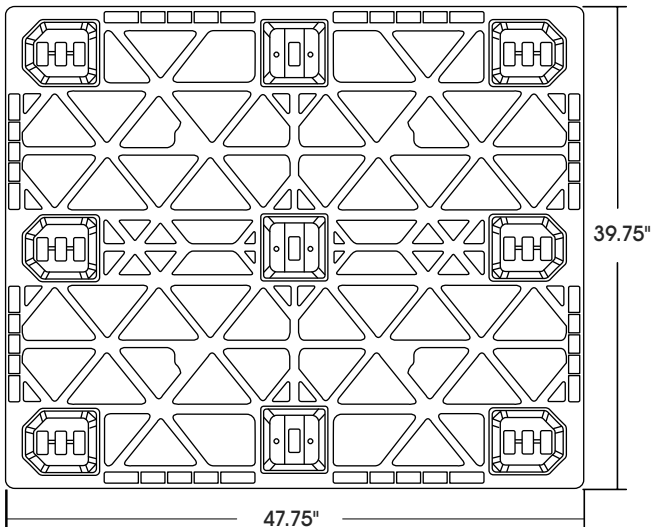

LONG SIDE VIEW

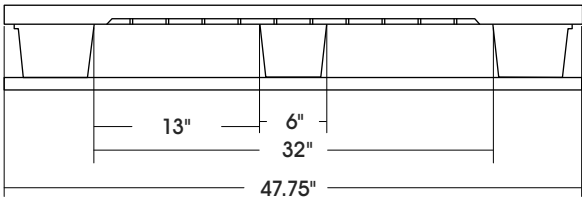

SHORT SIDE VIEW

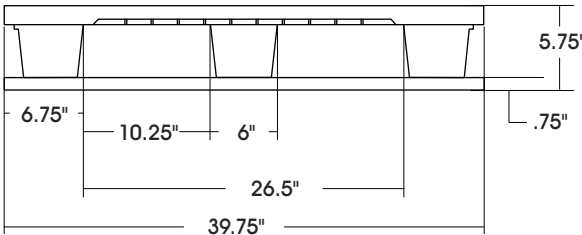

**SPECIFICATIONS**

MODEL #	DIMENSIONS		HEIGHT			ASSEMBLED TRAILER		NESTED UNASSEMBLED TRAILER		WEIGHT CAPACITY		WEIGHT
	L	W	FORK	OVERALL	NESTING	48'	53'	48'	53'	FLOOR	FORK	
H-10616	47.75"	39.62"	3.5"	5.75"	-----	374	432	924	1008	7,500 lbs.	3,000 lbs.	33 lbs.
H-10617	47.75"	39.62"	3.5"	5.75"	-----	374	432	924	1008	10,000 lbs.	5,000 lbs.	36 lbs.

# ASSEMBLY

Figure 1

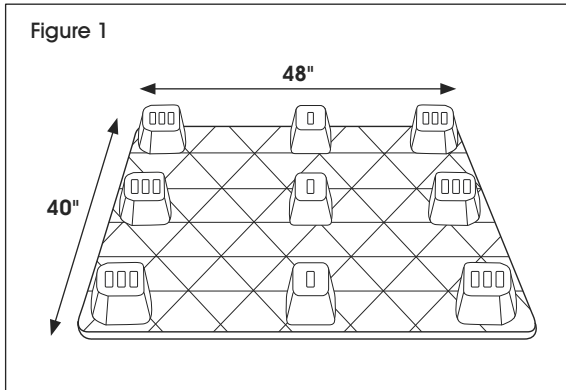

1. Lay the pallet face down on a hard flat surface. (See Figure 1)



**WARNING:** Pallet facing upward will prevent proper assembly of the pallet.

Figure 2

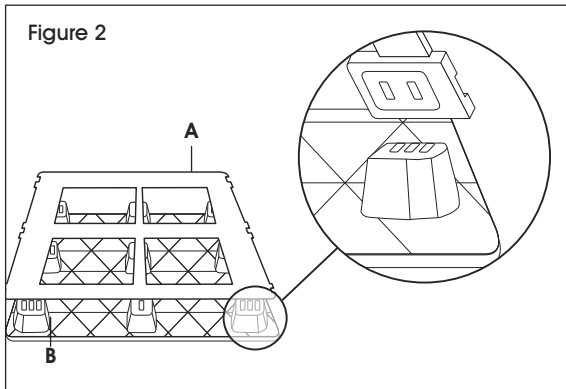

2. Align the tabs on the base (A) with the slots on the pallet legs (B). (See Figure 2)

Figure 3

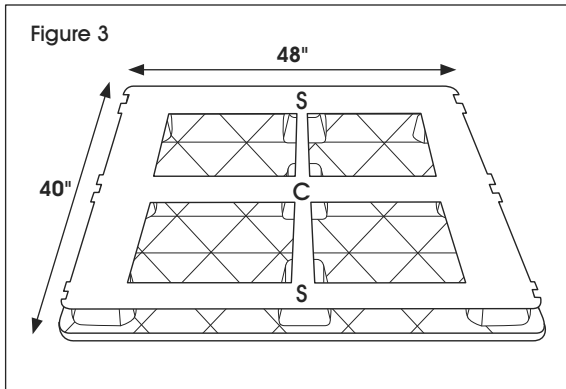

3. Apply pressure to the center runner (C) until it snaps together with the center leg. (See Figure 3)
4. Repeat step 3 on square legs first (S).
5. Repeat step 3 on remaining legs.

# ULINE H-10616, H-10617

## TARIMA DE USO PESADO PARA EXPORTACIÓN

800-295-5510  
uline.mx

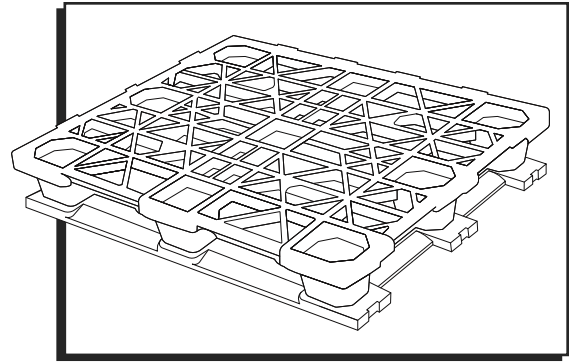

### DIMENSIONES DEL PRODUCTO

VISTA SUPERIOR

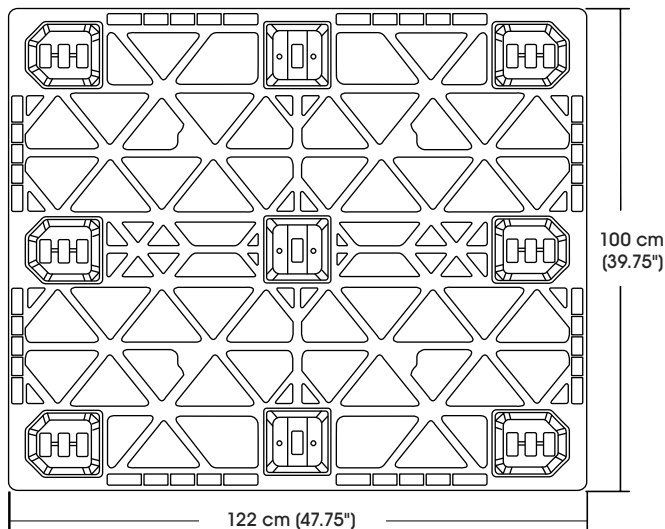

VISTA DEL LADO LARGO

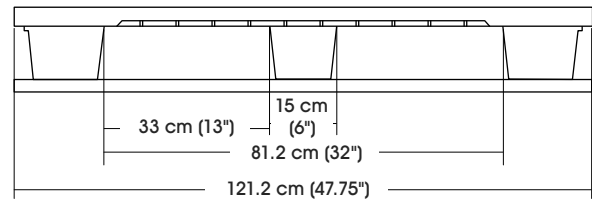

VISTA DEL LADO CORTO

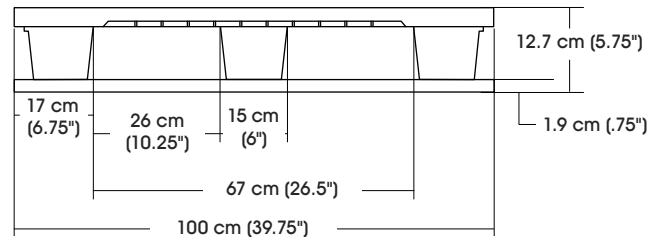

### ESPECIFICACIONES

MODELO NO.	DIMENSIONES		ALTO			ENSAMBLADAS EN TRÁILER		EMBONADAS SIN ENSAMBLAR EN TRÁILER		CAPACIDAD DE PESO		PESO
	LARGO	ANCHO	HORQUILLA	GENERAL	EMBONABLE	14.6 m (48')	16.15 m (53')	14.6 m (48')	16.15 m (53')	PISO	HORQUILLA	
H-10616	122 cm (47.75")	100 cm (39.62")	8.9 cm (3.5")	14.6 cm (5.75")	-----	374	432	924	1008	3401 kg (7,500 lb)	1360 kg (3,000 lb)	14.9 kg (33 lbs.)
	122 cm (47.75")	100 cm (39.62")	8.9 cm (3.5")	14.6 cm (5.75")	-----	374	432	924	1008	4535 kg (10,000 lb)	2267 kg (5,000 lb)	
H-10617	122 cm (47.75")	100 cm (39.62")	8.9 cm (3.5")	14.6 cm (5.75")	-----	374	432	924	1008	4535 kg (10,000 lb)	2267 kg (5,000 lb)	16.3 kg (36 lbs.)

# ENSAMBLE

Diagrama 1

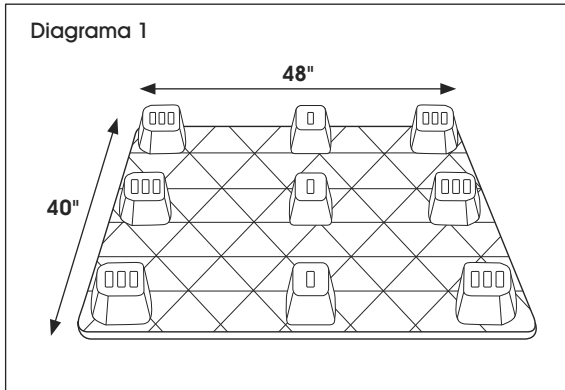

1. Coloque la tarima boca abajo y sobre una superficie plana. (Vea Diagrama 1)



**ADVERTENCIA:** La tarima hacia arriba impedirá su ensamble adecuado.

Diagrama 2

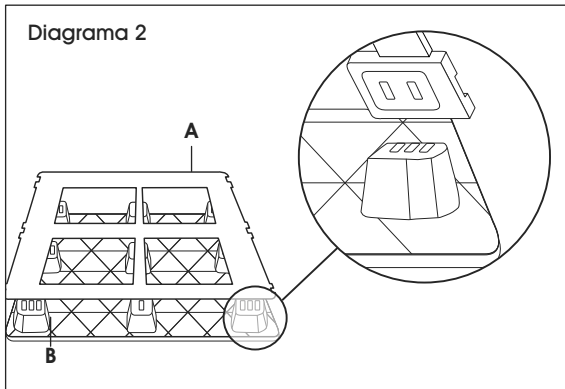

2. Alinee las pestañas de la base (A) con las ranuras de las patas de la tarima (B). (Vea Diagrama 2)

Diagrama 3

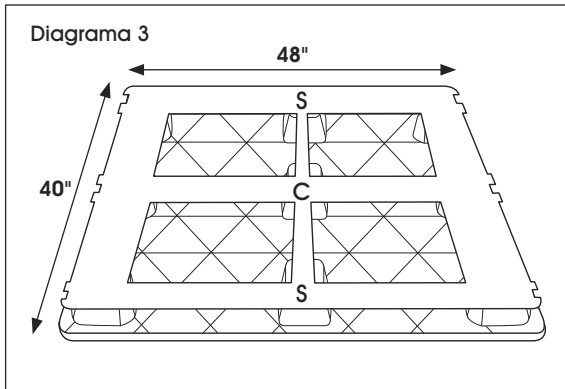

3. Haga presión en el corredor central hasta que encaje con la pata central. (Vea Diagrama 3)
4. Repita el paso 3 primero en las patas cuadradas (S).
5. Repita el paso 3 en las patas restantes.

**ULINE**

800-295-5510  
uline.mx

# ULINE H-10616, H-10617

## PALETTE D'EXPORTATION ROBUSTE

1-800-295-5510  
uline.ca

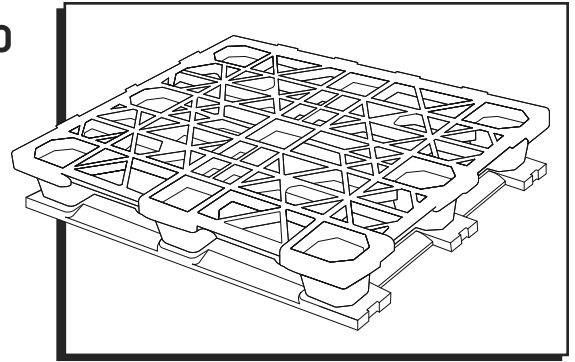

### DIMENSIONS DU PRODUIT

VUE DE DESSUS

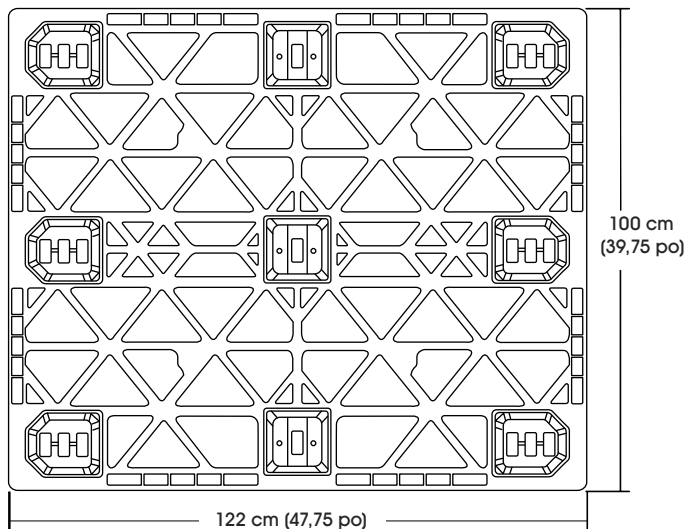

VUE DU CÔTÉ LONG

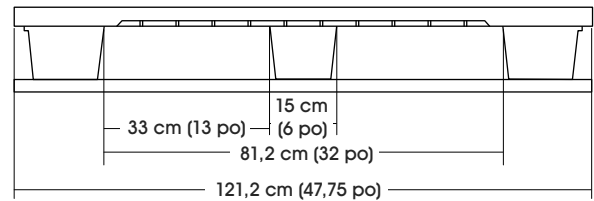

VUE DU CÔTÉ COURT

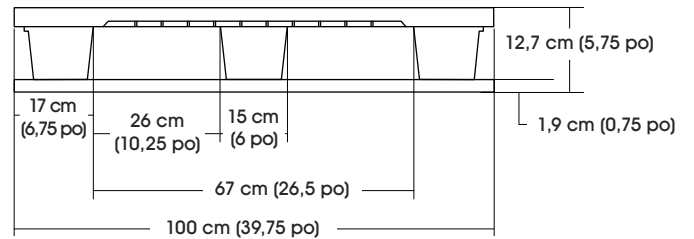

### SPÉCIFICATIONS

N° DE MODÈLE	DIMENSIONS		HAUTEUR			ASSEMBLÉ PAR REMORQUE		NON ASSEMBLÉ ET EMBOÎTÉ PAR REMORQUE		CAPACITÉ PONDÉRALE		POIDS
	LONG.	LARG.	FOURCHE	TOTALE	EMBOÎTEMENT	14,6 m (48 pi)	16,15 m (53 pi)	14,6 m (48 pi)	16,15 m (53 pi)	PLANCHER	FOURCHE	
H-10616	122 cm (47,75 po)	100 cm (39,62 po)	8,9 cm (3,5 po)	14,6 cm (5,75 po)	----	374	432	924	1 008	3 401 kg (7 500 lb)	1 360 kg (3 000 lb)	14,9 kg (33 lb)
H-10617	122 cm (47,75 po)	100 cm (39,62 po)	8,9 cm (3,5 po)	14,6 cm (5,75 po)	----	374	432	924	1 008	4 535 kg (10 000 lb)	2 267 kg (5 000 lb)	16,3 kg (36 lb)

# ASSEMBLAGE

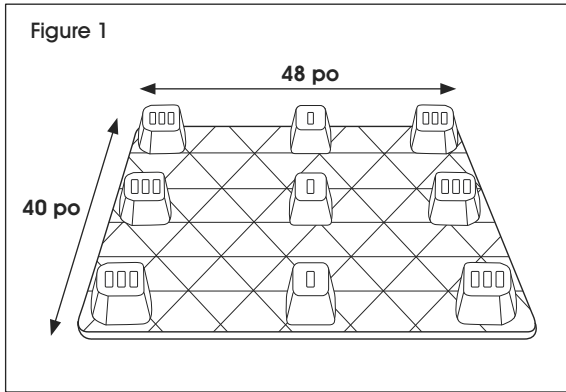

1. Déposez la palette à l'envers sur une surface plane dure. (Voir Figure 1)



**AVERTISSEMENT** : La palette ne sera pas assemblée correctement si elle est posée à l'endroit.

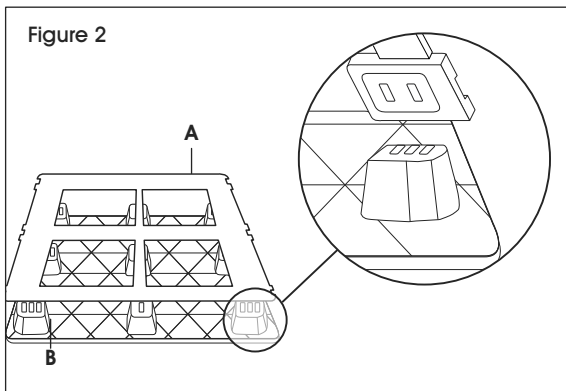

2. Alignez les languettes de la base (A) sur les fentes des pieds de la palette (B). (Voir Figure 2)

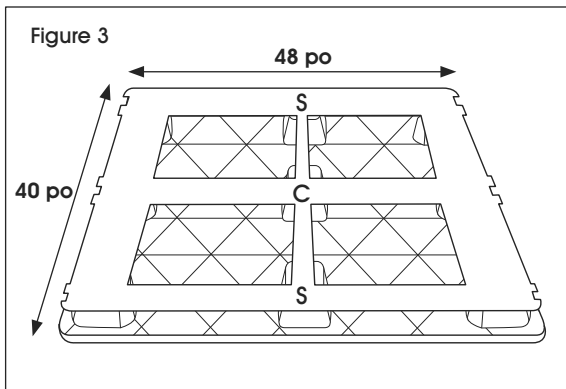

3. Appliquez de la pression sur la membrure centrale (C) jusqu'à ce qu'elle s'enclenche dans le bloc central. (Voir Figure 3)
4. Répétez l'étape 3 en commençant par les pieds carrés (S).
5. Répétez l'étape 3 sur les pieds restants.

**ULINE**

1-800-295-5510  
uline.ca