

# ULINE H-10682, H-10683 POLY TUB CART

1-800-295-5510  
uline.com

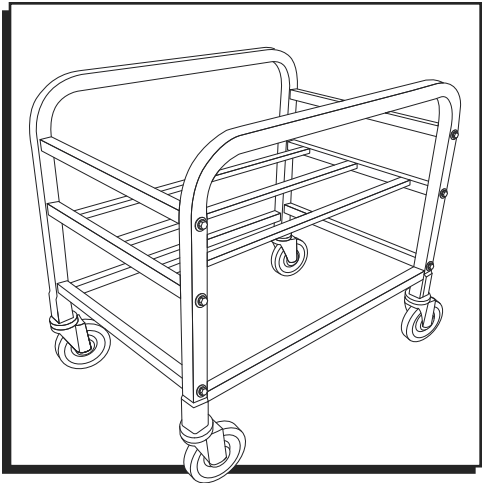

## TOOLS NEEDED



Rubber Mallet

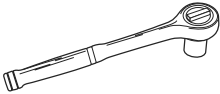

Socket Wrench



13 mm Socket

## PARTS

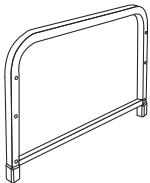

Upright x 2

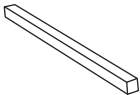

Support Bar x 4

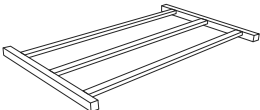

Shelf x 1

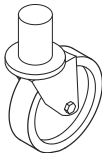

Swivel Caster x 4

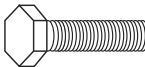

Bolt x 12



Washer x 12

## ASSEMBLY

1. Attach two support bars to bottom of uprights using four bolts and washers. (See Figure 1)

2. Attach shelf to middle of uprights using four bolts and washers. (See Figure 2)

 **NOTE:** Do not fully tighten bolts until assembly is complete.

Figure 1

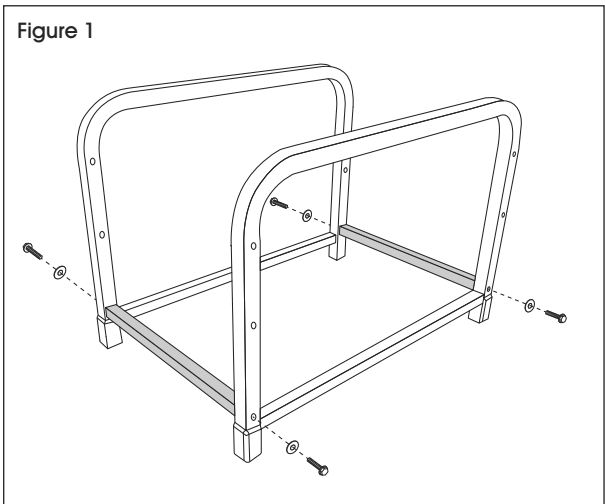
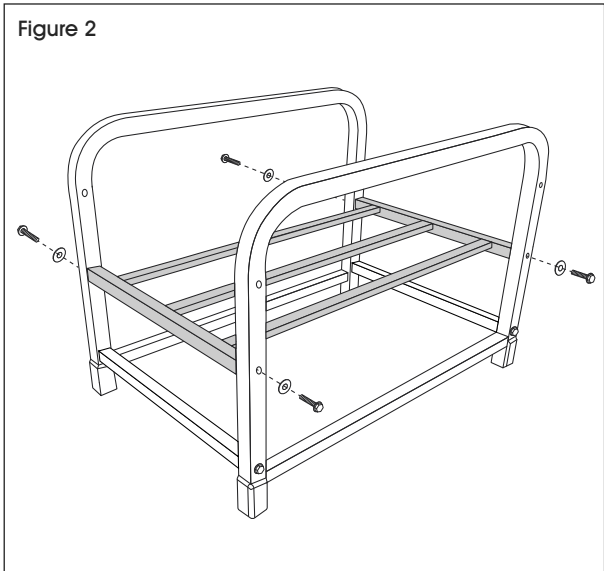

Figure 2



## ASSEMBLY CONTINUED

3. Attach remaining two support bars to top of uprights using four bolts and washers. (See Figure 3)



**NOTE:** Ensure unit is level.



**NOTE:** Tighten all bolts using socket wrench and 13 mm socket.

Figure 3

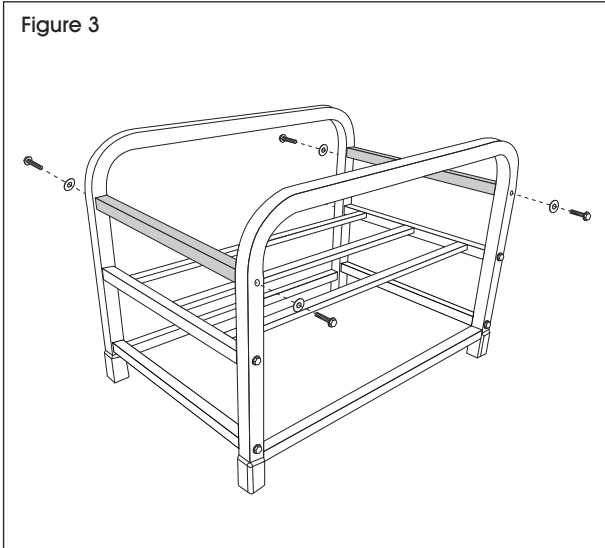

4. Tap casters into bottom of uprights with mallet. (See Figure 4)

Figure 4

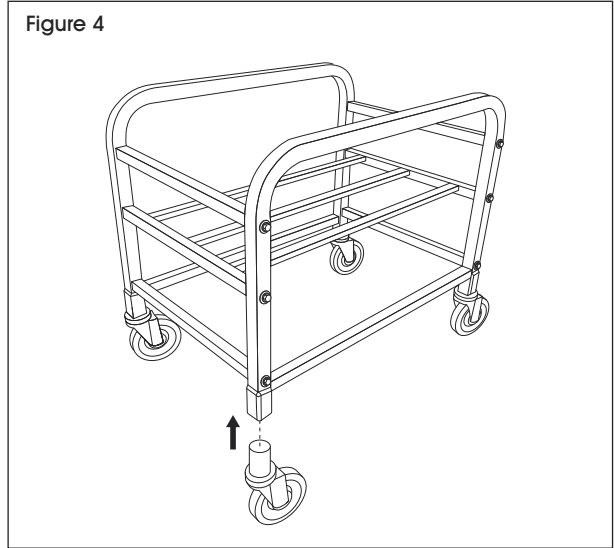

5. If casters are too loose to fit, tighten rubber stopper. If casters struggle to fit, loosen rubber stopper. (See Figure 5)

Figure 5

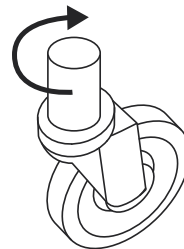

Tighten clockwise  
to make thicker.

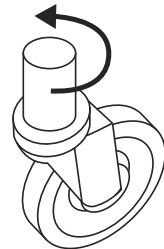

Loosen counter-clockwise  
to make thinner.

**ULINE**

1-800-295-5510  
uline.com

**ULINE** H-10682, H-10683

# CARRITO PARA TINAS DE POLIETILENO

800-295-5510

uline.mx

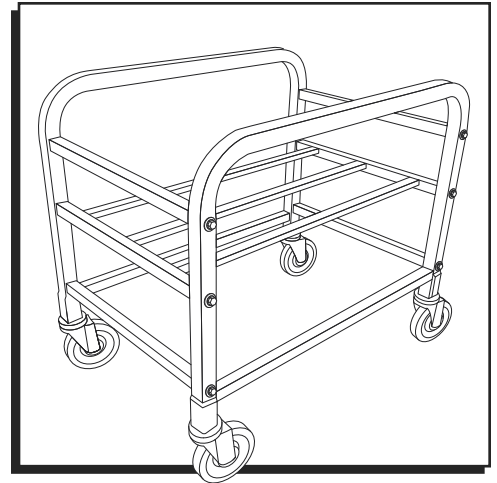

## HERRAMIENTAS NECESARIAS



Mazo de Caucho

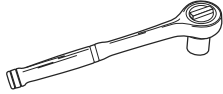

Llave de Dado



Dado de 13 mm

## PARTES

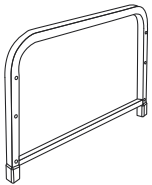

2 Marcos

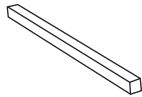

4 Barras de Soporte

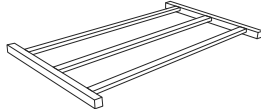

1 Repisa

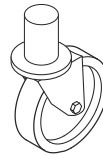

4 Ruedas Giratorias

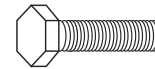

12 Pernos



12 Rondanas

## ENSAMBLE

1. Fije las dos barras de soporte a la parte inferior de los marcos usando cuatro pernos y rondanas. (Vea Diagrama 1)



**NOTA:** No apriete los pernos por completo hasta que termine de ensamblar.

2. Fije la repisa a la parte central de los marcos usando cuatro pernos y rondanas. (Vea Diagrama 2)

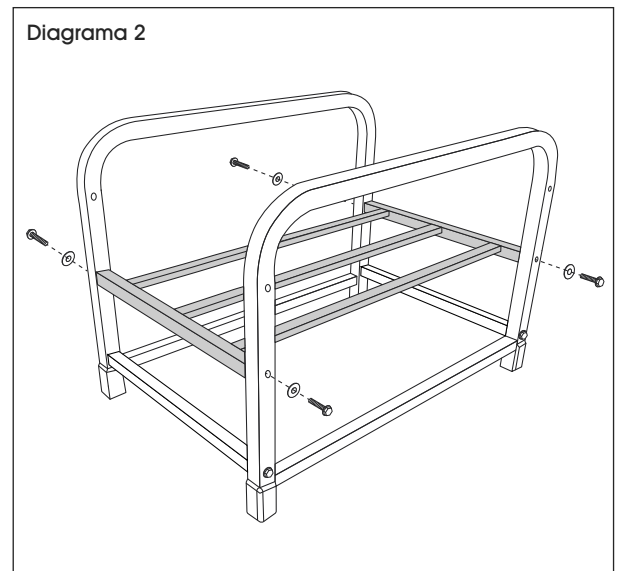
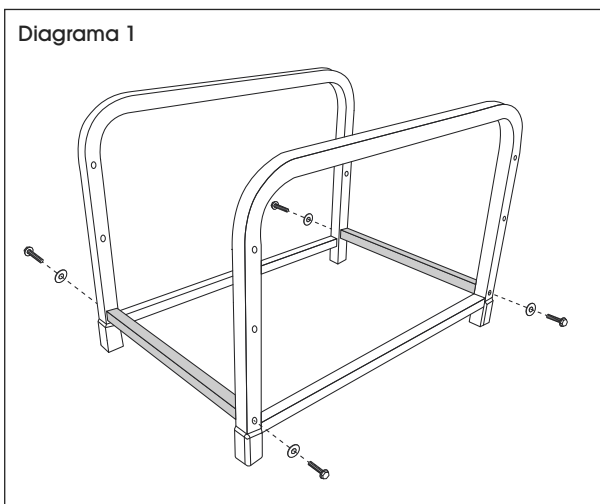

## CONTINUACIÓN DE ENSAMBLE

3. Fije los dos soportes restantes a la parte superior de los marcos usando cuatro pernos y rondanas. (Vea Diagrama 3)

 **NOTA:** Asegúrese de que la unidad esté nivelada.

 **NOTA:** Apriete todos los pernos usando la llave de dado y el dado de 13 mm.

Diagrama 3

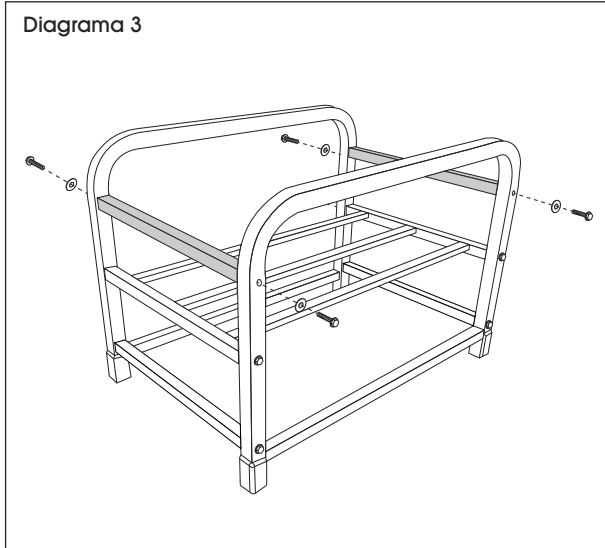

4. Coloque las ruedas en la parte inferior de los marcos y golpéelos ligeramente con un mazo. (Vea Diagrama 4)

Diagrama 4

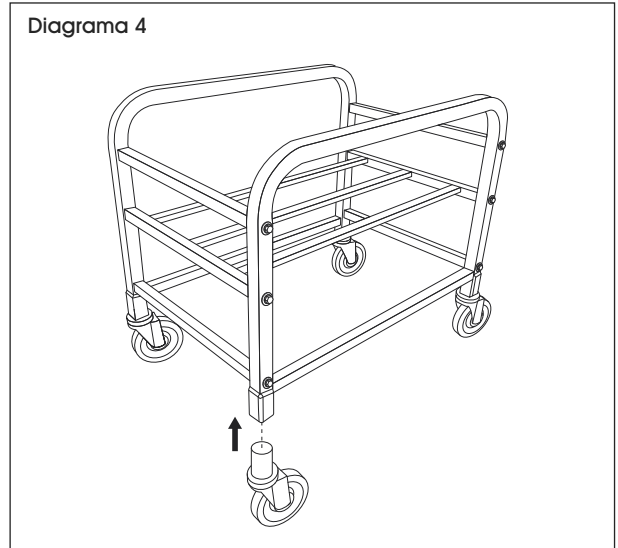

5. Si las ruedas están muy sueltas y no ajustan bien, engrose el tope de caucho. Si tiene problemas para embonarlas, agudice el tope. (Vea Diagrama 5)

Diagrama 5

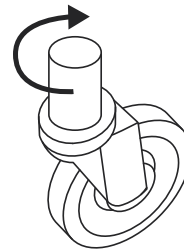

Apriete en sentido de las manecillas del reloj para engrosar.

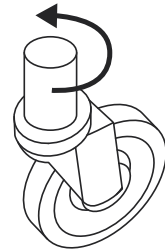

Gire en sentido contrario a las manecillas del reloj para agudizar.

**ULINE**

800-295-5510  
uline.mx

**ULINE** H-10682, H-10683

# CHARIOT POUR BAC EN POLYÉTHYLÈNE

1-800-295-5510  
uline.ca

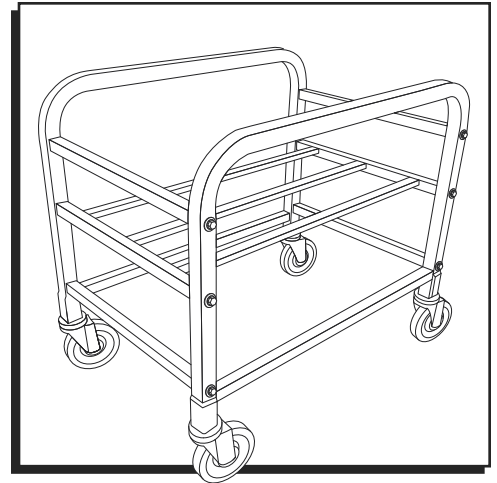

## OUTILS REQUIS



Maillet en caoutchouc

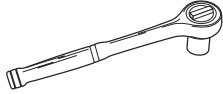

Clé à douille



Douille de 13 mm

## PIÈCES

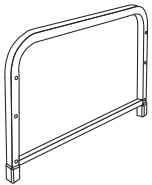

Montant x 2

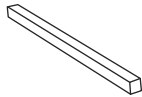

Barre de support x 4

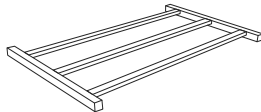

Tablette x 1

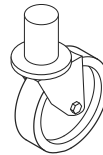

Roulette pivotante x 4

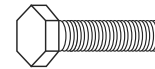

Boulon x 12



Rondelle x 12

## MONTAGE

1. Fixez deux barres de support au bas des montants avec quatre boulons et rondelles. (Voir Figure 1)



**REMARQUE :** Attendez d'avoir terminé le montage pour serrer complètement les boulons.

2. Fixez la tablette au centre des montants avec quatre boulons et rondelles. (Voir Figure 2)

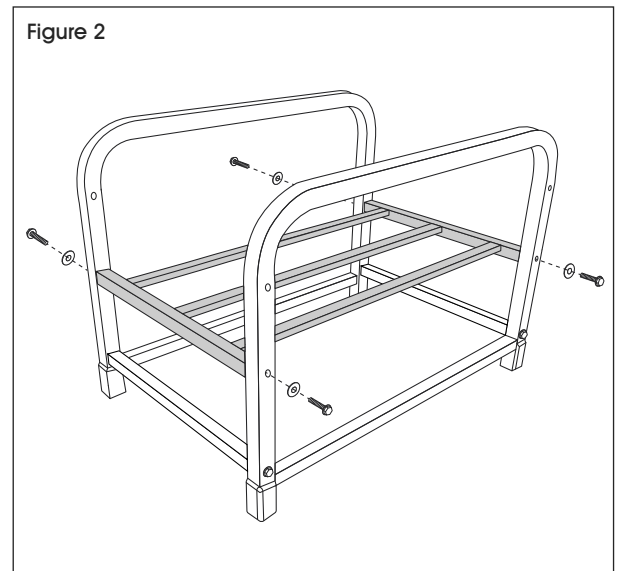
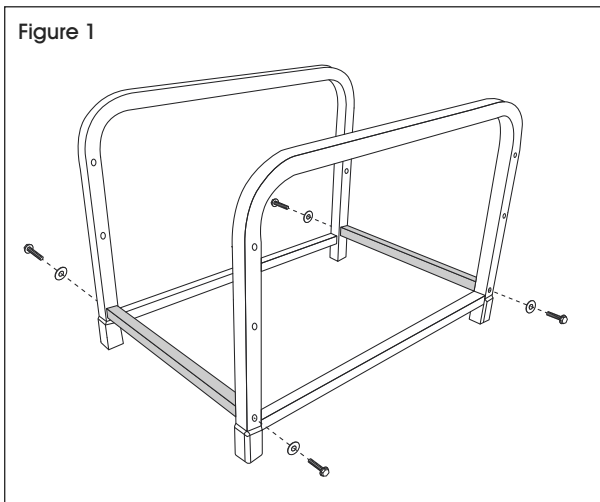

## MONTAGE SUITE

3. Fixez les deux autres barres de support en haut des montants avec quatre boulons et rondelles. (Voir Figure 3)

 **REMARQUE :** Assurez-vous que le chariot est nivelé.

 **REMARQUE :** Serrez tous les boulons avec la clé et la douille de 13 mm.

Figure 3

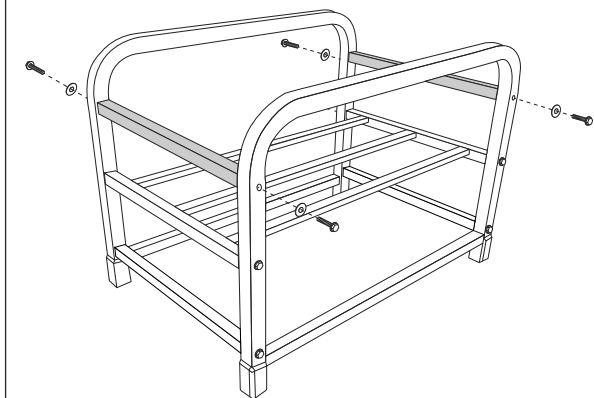

4. Insérez les roulettes dans le bas des montants en tapant dessus avec le maillet. (Voir Figure 4)

Figure 4

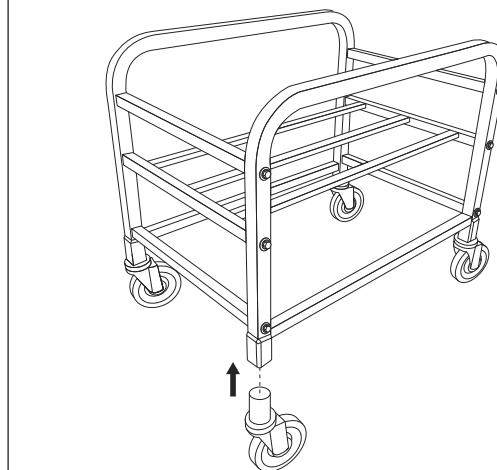

5. Si les roulettes sont trop lâches, serrez le bouchon en caoutchouc. Si les roulettes ont du mal à s'adapter, desserrez le bouchon en caoutchouc. (Voir Figure 5)

Figure 5

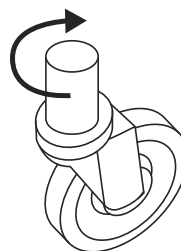

Serrez dans le sens horaire pour augmenter l'épaisseur.

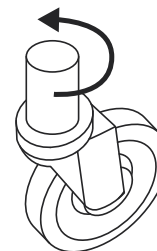

Desserrez dans le sens antihoraire pour réduire l'épaisseur.

**ULINE**

1-800-295-5510  
uline.ca