

ULINE H-10734 CUTLEREASE™ TOUCHLESS UTENSIL DISPENSER

1-800-295-5510
uline.com

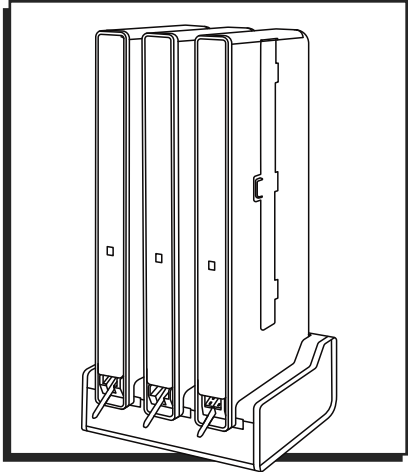

LOADING

1. Slide tower partially forward to expose release trigger at bottom. (See Figure 1)

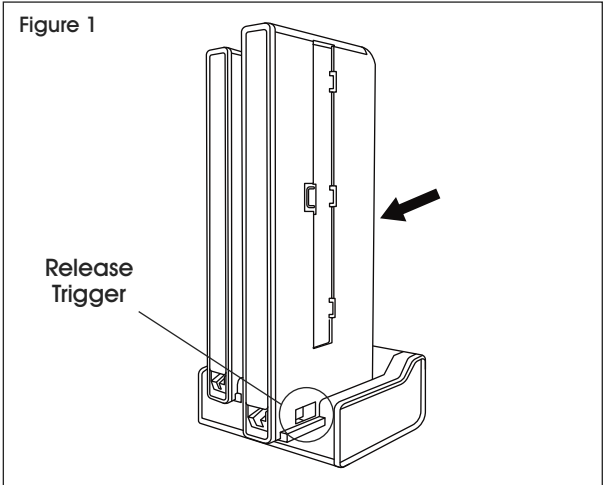

2. Open top and side doors. Select cutlery pack for tower type. (See Figure 2)

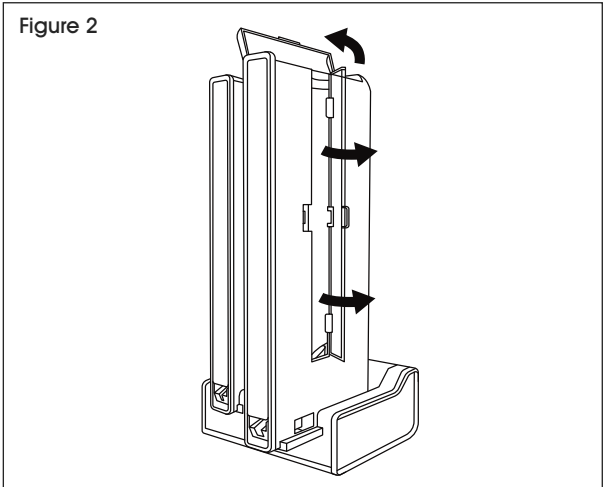

3. Hold cutlery pack by top and bottom tape tabs. With cutlery facing down, slide into top opening and gently guide into tower with tape tabs facing outward. (See Figure 3)

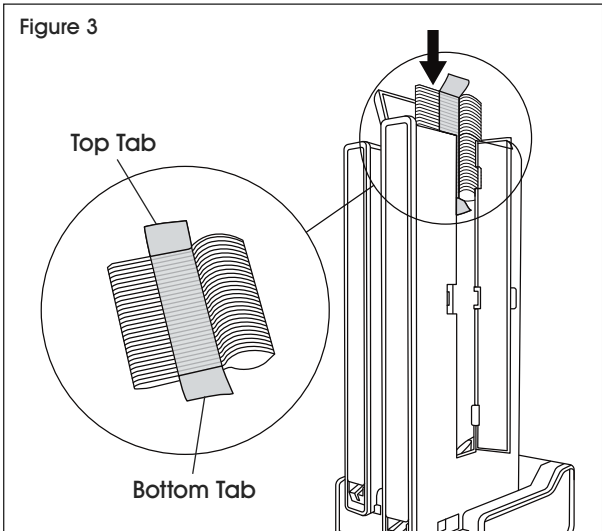

4. Remove tape by pulling top tab gently downward. Close top and side doors. (See Figure 4)

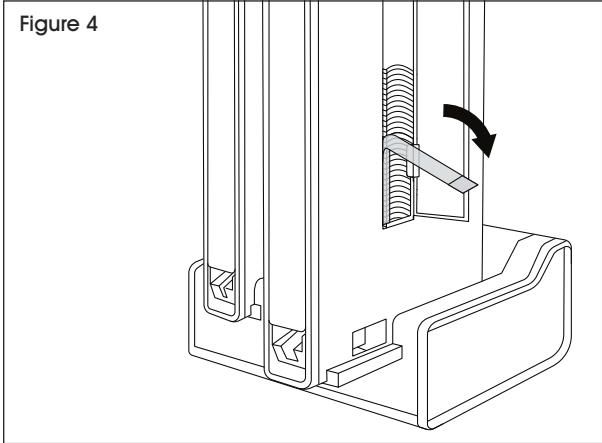

LOADING CONTINUED

5. To deploy first piece of cutlery, press and release trigger quickly. A cutlery handle is now ready for dispensing. (See Figure 5)

 **NOTE:** Do not hold or press trigger multiple times. This may cause the cutlery to jam.

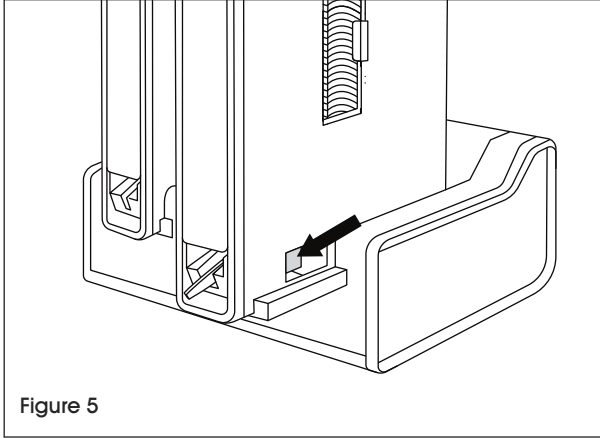

6. Slide tower back into dispenser base. Cutlery dispensing is now ready for use. (See Figure 6)

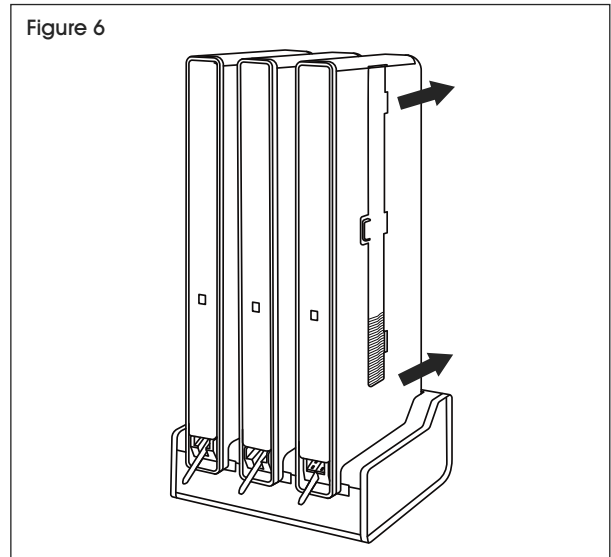

ULINE

1-800-295-5510
uline.com

ULINE H-10734

CUTLEREASE™ DESPACHADOR DE CUBIERTOS MANOS LIBES

800-295-5510
uline.mx

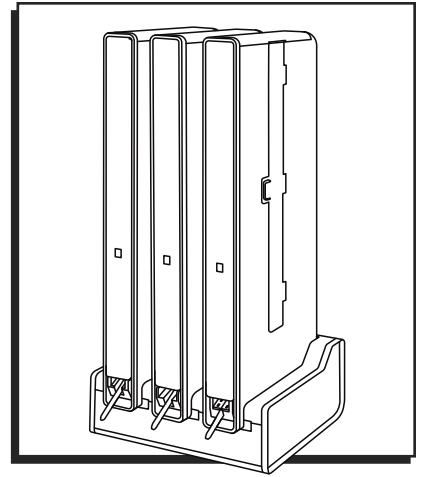

CARGA

1. Deslice la torre parcialmente hacia adelante para mostrar el gatillo de liberación de la parte inferior. (Vea Diagrama 1)

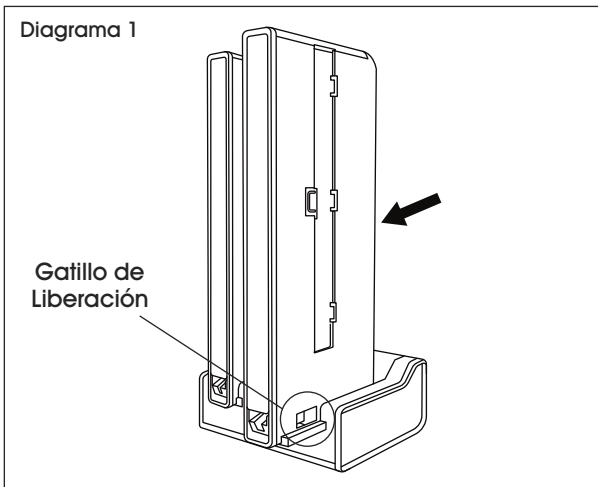

2. Abra las puertas superiores y laterales. Seleccione el paquete de cubiertos para el tipo de torre. (Vea Diagrama 2)

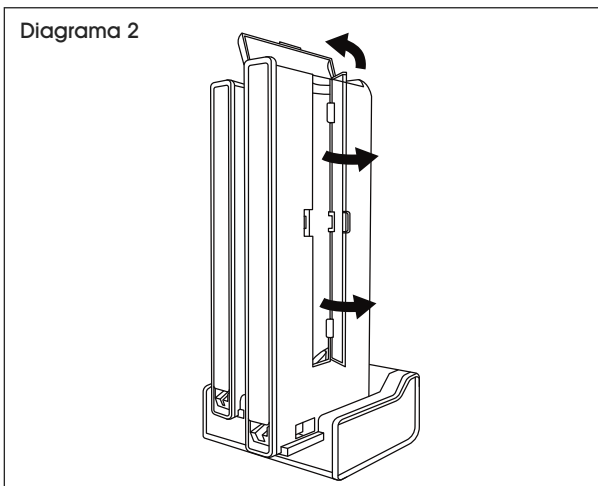

3. Sostenga el paquete de cubiertos por las pestañas de cinta superior e inferior. Con los cubiertos hacia abajo, deslícelos en la abertura superior y guíelos suavemente en la torre con las pestañas de cinta hacia afuera. (Vea Diagrama 3)

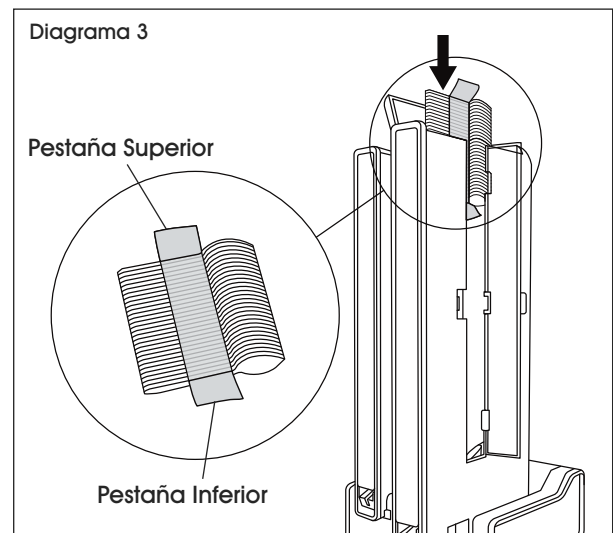

4. Retire la cinta jalando de la pestaña superior suavemente hacia abajo. Cierre las puertas superiores y laterales. (Vea Diagrama 4)

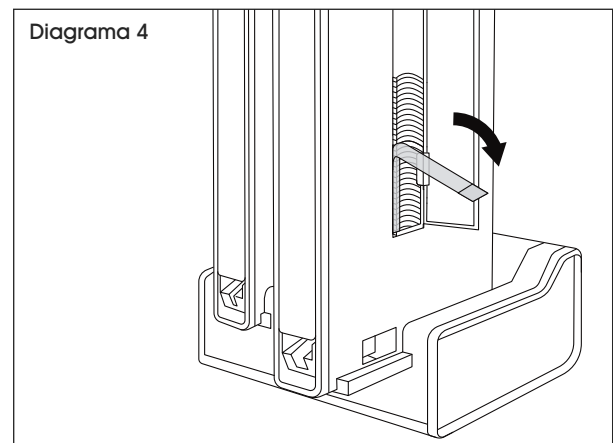

CONTINUACIÓN DE CARGA

5. Para despachar el primer cubierto, presione y suelte el gatillo rápidamente. Un mango de cubierto está listo para despacharse. (Vea Diagrama 5)



NOTA: No sostenga o presione el gatillo múltiples veces. Esto puede causar que el cubierto se atasque.



Diagrama 5

6. Deslice la torre de nuevo en la base del despachador. El despachador de cubiertos ya está listo para usarse. (Vea Diagrama 6)

Diagrama 6

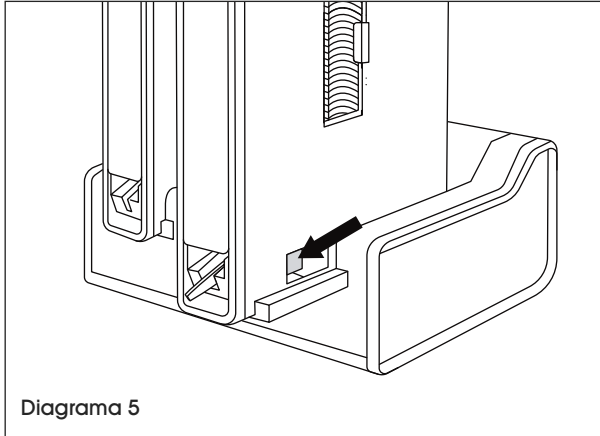
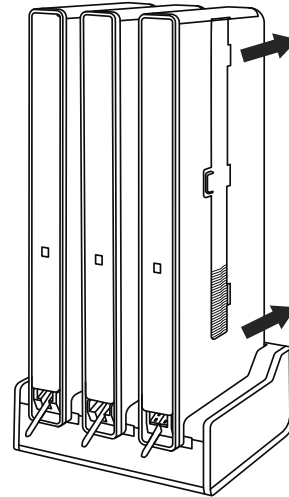

ULINE H-10734

CUTLEREASE^{MC} – DISTRIBUTEUR D'USTENSILES SANS CONTACT

1-800-295-5510
uline.ca

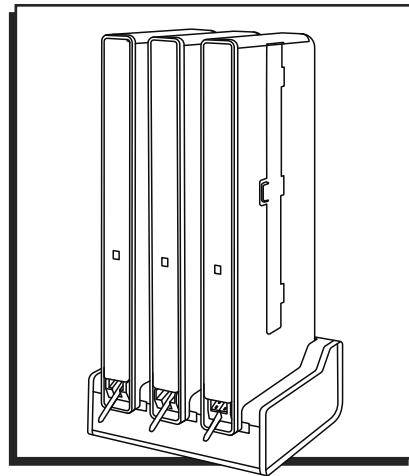

CHARGEMENT

1. Faites glisser la tour partiellement vers l'avant pour accéder à la gâchette située en bas. (Voir Figure 1)

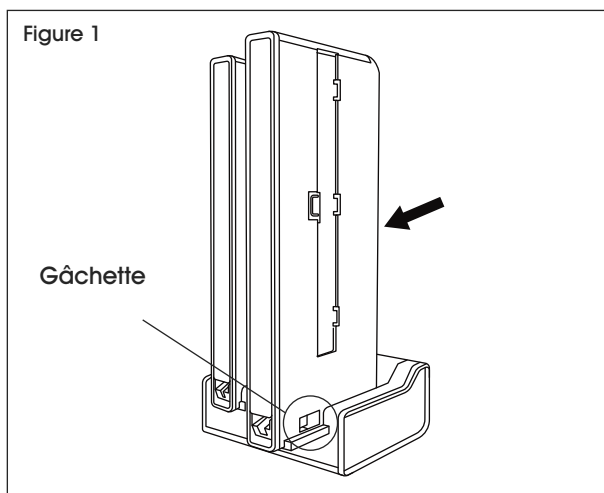

2. Ouvrez les portes supérieure et latérale. Choisissez l'ustensile approprié à la tour. (Voir Figure 2)

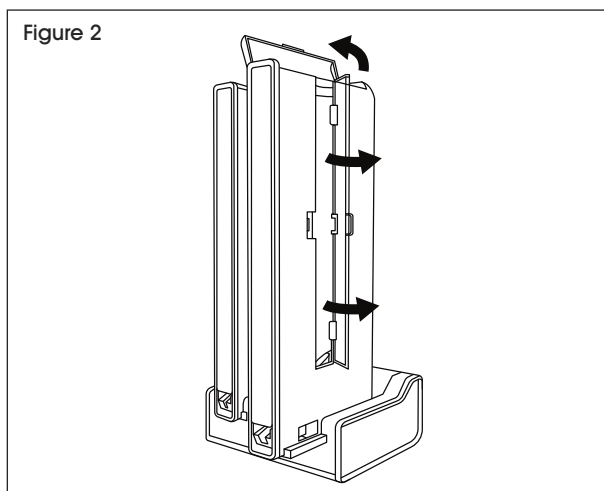

3. Tenez le paquet d'ustensile par les languettes supérieures et inférieures du ruban adhésif. Avec les ustensiles orientés vers le bas, glissez-les avec précaution dans l'ouverture supérieure de la tour avec les languettes de ruban adhésif orientés vers l'extérieur. (Voir Figure 3)

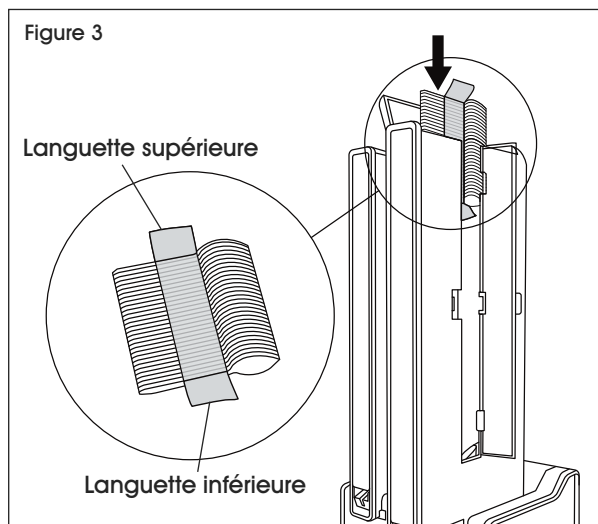

4. Retirez le ruban adhésif en tirant doucement la languette supérieure vers le bas. Fermez les portes supérieure et latérale. (Voir Figure 4)

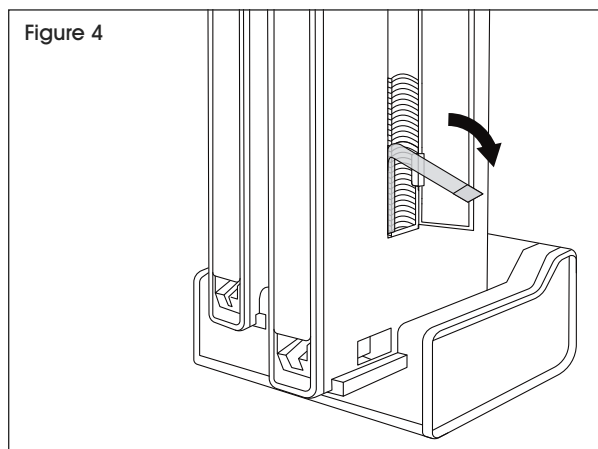

CHARGEMENT SUITE

5. Pour faire sortir le premier ustensile, appuyez sur la gâchette et relâchez-la rapidement. L'ustensile est maintenant prêt à être distribué. (Voir Figure 5)

 **REMARQUE :** Ne maintenez ou n'appuyez pas plusieurs fois sur la gâchette. Les ustensiles risqueraient de se bloquer.

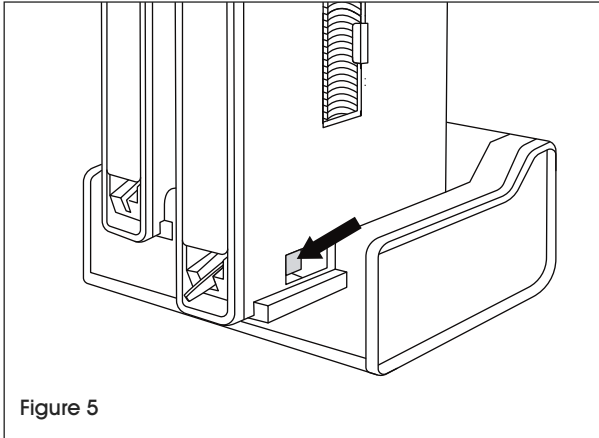

6. Remettez la tour en place dans la base du distributeur. Le distributeur est maintenant prêt à l'emploi. (Voir Figure 6)

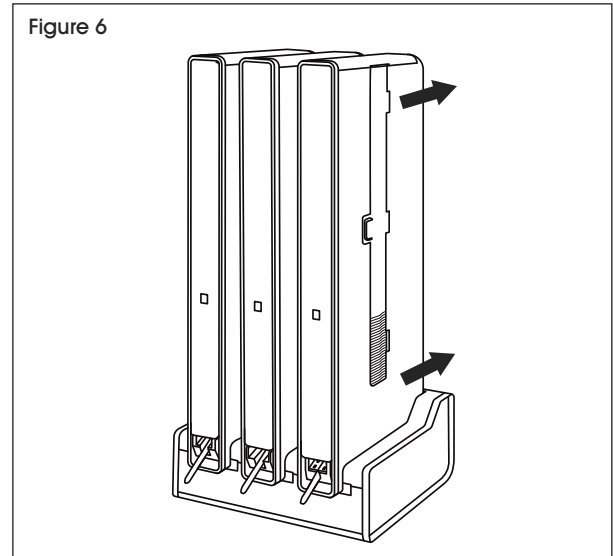

ULINE

1-800-295-5510
uline.ca