

ULINE H-10768

ESD RESTOCKING CART

40" TALL

1-800-295-5510
uline.com

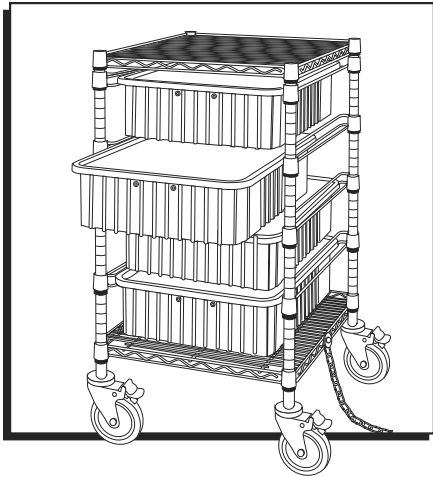

TOOL NEEDED



Rubber Mallet

PARTS



Two-Piece Post x 4

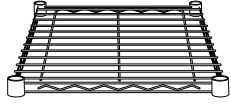

Shelf x 2

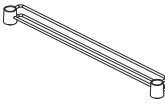

Box Slide x 8



Aluminum Shelf Support x 24 Sets

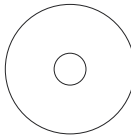

Large Washer x 2



Grounding Chain x 1



Hex Head Bolt x 1



Donut Bumper x 4



Retaining Ring x 16



Lock Washer x 1



Locknut x 1



Conductive Caster x 4

CASTER INSTALLATION

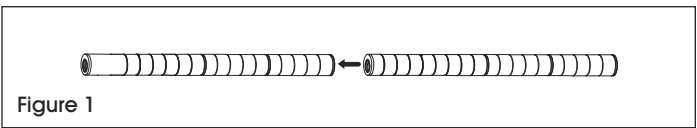

Figure 1

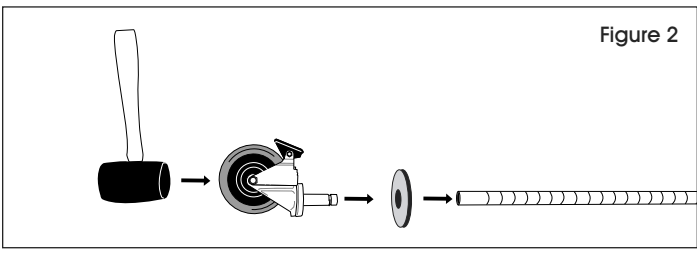

Figure 2

TO INSTALL CASTERS

1. Connect posts by screwing together. (See Figure 1)
2. Make sure post is positioned as shown. (See Figure 2)
3. Engage the wheel brakes to keep casters from rolling during assembly. Use a rubber mallet to tap caster stems through donut bumper and into posts. (See Figure 2)

UNIT ASSEMBLY

1. Start with the bottom shelf. Snap the interlocking pieces of a shelf support (wide end down) around the post at the lowest groove where shelf is to be located. Slide the support up or down until it snaps into the groove. Add a shelf support to the same height on the remaining posts. (See Figure 3)

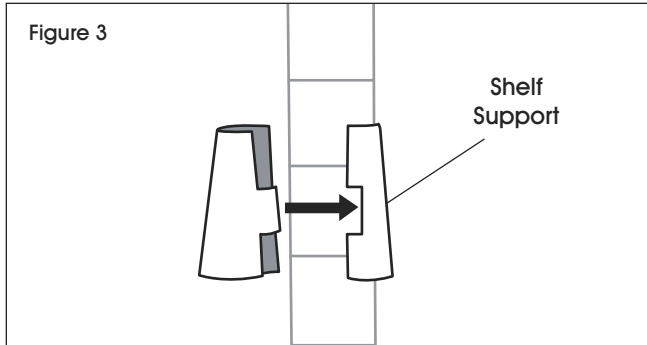

2. Slide posts through underside of shelf until shelf slides firmly over supports. (See Figure 4)

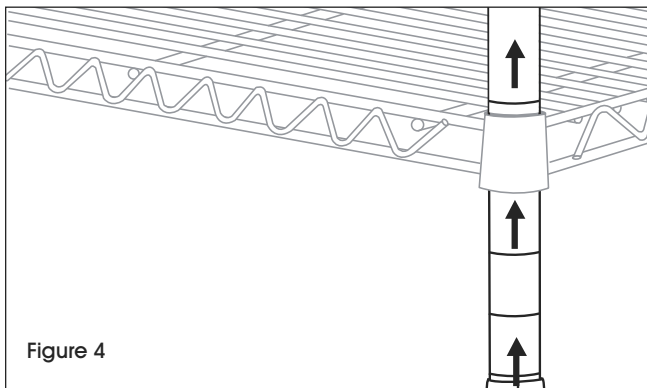

3. Stand unit upright. Gently tap shelf down to secure it using rubber mallet. (See Figure 5)

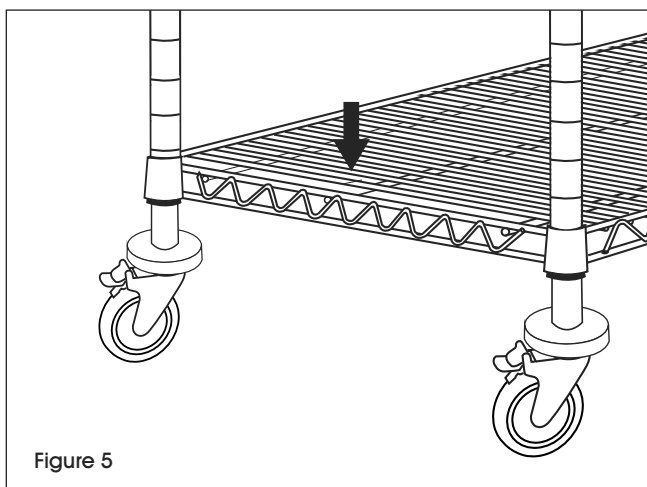

4. Place shelf supports on each post, 6" above the bottom shelf to allow room for divider boxes. Slide box slides onto posts on each side of shelving unit. Gently tap box slides down to secure. (See Figure 6)

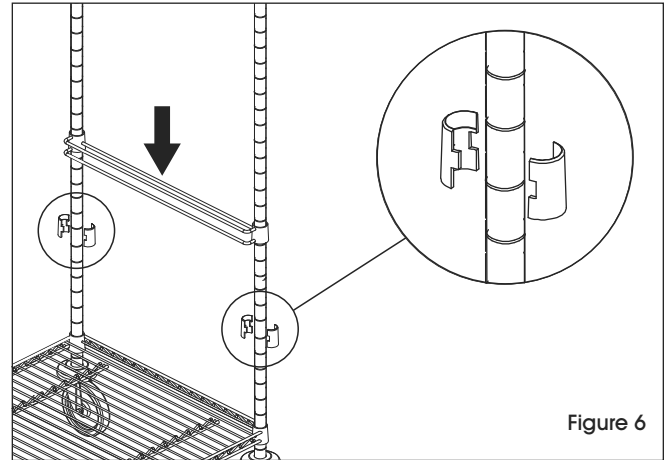

5. Repeat this process with the remaining box slides with 6" between each set of shelf supports.
6. Add shelf supports to very top of posts. Place top shelf on shelf supports and gently tap with rubber mallet. (See Figure 7)

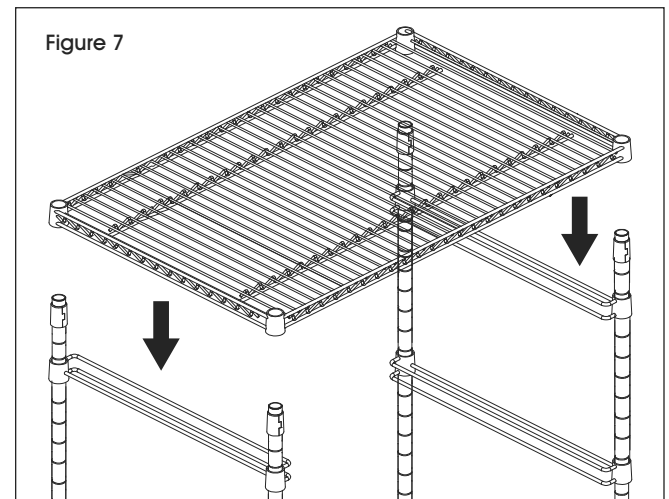

ULINE

1-800-295-5510
uline.com

ULINE H-10768

CARRITO PARA RESURTIR ESD – 40" DE ALTO

800-295-5510

uline.mx

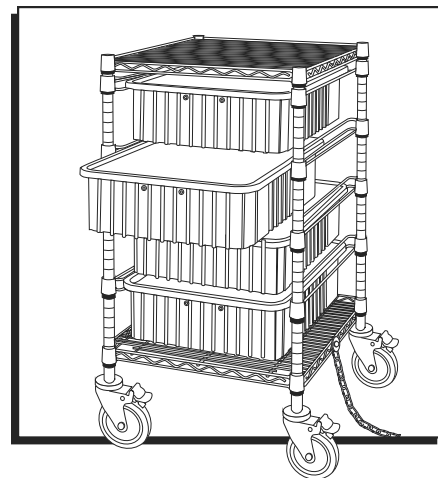

HERRAMIENTA NECESARIA



Mazo de Caucho

PARTES



4 Postes de Dos Piezas

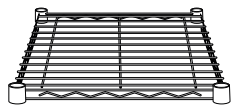

2 Repisas

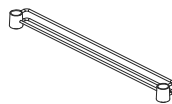

8 Deslizadores de Gavetas



24 Sets de Soportes de Aluminio para Repisa

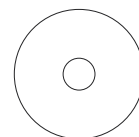

2 Rondanas Grandes

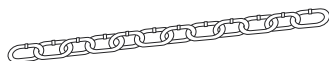

1 Cadena para Hacer Tierra



1 Perno de Cabeza Hexagonal



4 Parachosques Circulares



16 Anillos de Retención



1 Rondana de Seguridad



1 Contratuerca



4 Ruedas Conductivas

INSTALACIÓN DE LAS RUEDAS



Diagrama 1



Diagrama 2

PARA INSTALAR LAS RUEDAS

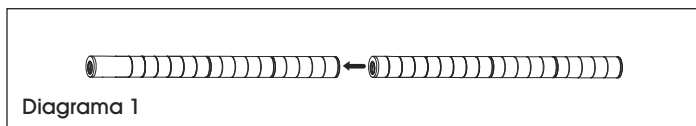
1. Conecte los postes atornillándolos uno con el otro. (Vea Diagrama 1)
2. Asegúrese de que el poste esté colocado como se muestra. (Vea Diagrama 2)
3. Ponga los frenos a las ruedas para evitar que giren durante la instalación. Utilice un mazo de caucho para insertar el vástago de las ruedas a través del parachosques circular y el poste. (Vea Diagrama 2)

ENSAMBLE DE LA UNIDAD

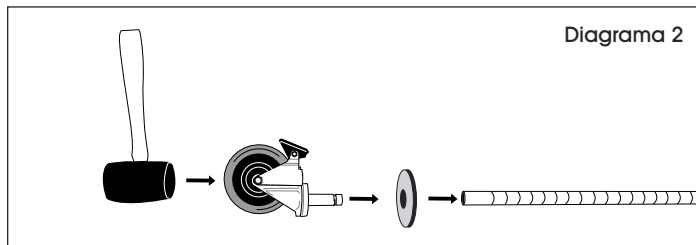
1. Comience con la repisa inferior. Fije las partes interconectables de un soporte para repisa (con la parte ancha hacia abajo) alrededor del poste en la ranura más baja donde desee colocar la repisa. Deslice el soporte hacia arriba o abajo hasta que quede fijo en la ranura. Agregue un soporte para repisa a la misma altura en los postes restantes. (Vea Diagrama 3)

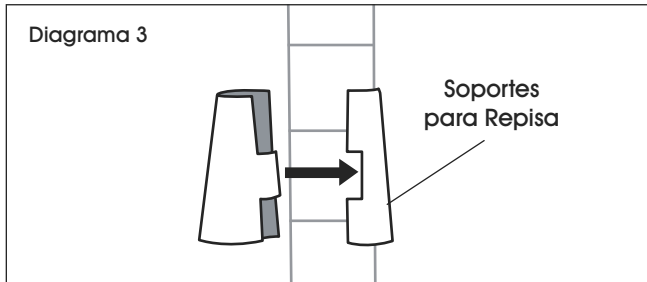

2. Deslice los postes a través de la parte inferior de la repisa hasta que la misma se deslice firmemente sobre los soportes. (Vea Diagrama 4)

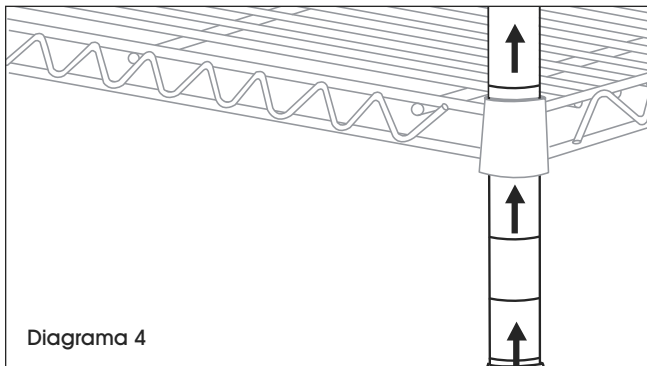

3. Enderece la unidad. Golpee levemente la repisa con el mazo de caucho para asegurarla. (Vea Diagrama 5)

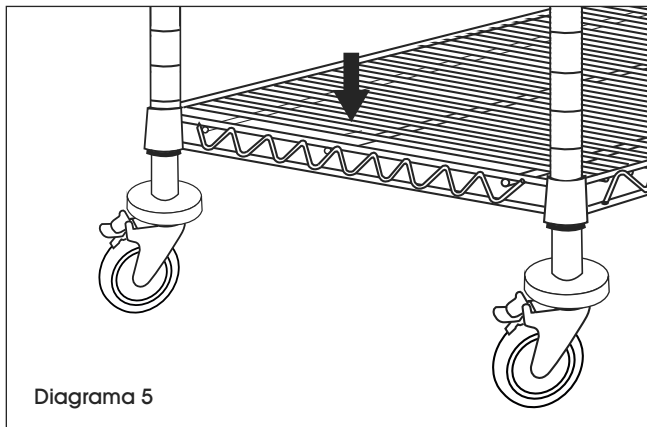

4. Coloque los soportes para repisa en cada poste, 6" arriba de la repisa inferior para dejar espacio para las cajas separadoras. Deslice las guías de gavetas en los postes en cada lado de la unidad de estantería. Para asegurar las guías de gavetas golpee suavemente hacia abajo. (Vea Diagrama 6)

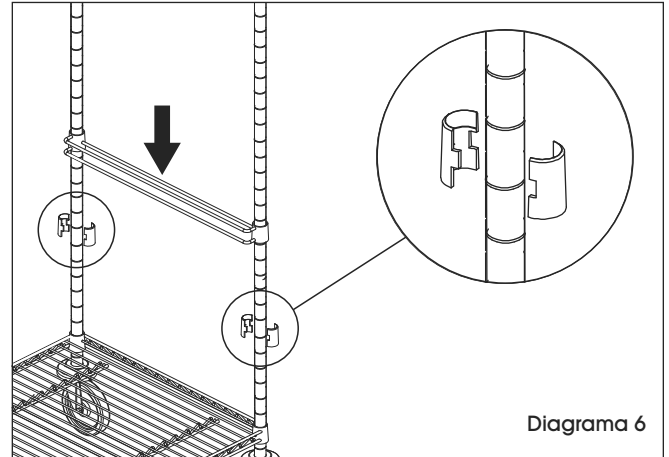

5. Repita el proceso con el resto de los deslizadores de gavetas dejando 6" entre cada set de soportes para repisa.
6. Agregue soportes para repisa en la parte superior de los postes. Coloque la repisa superior en los soportes para repisa y golpéela suavemente con un mazo de caucho. (Vea Diagrama 7)

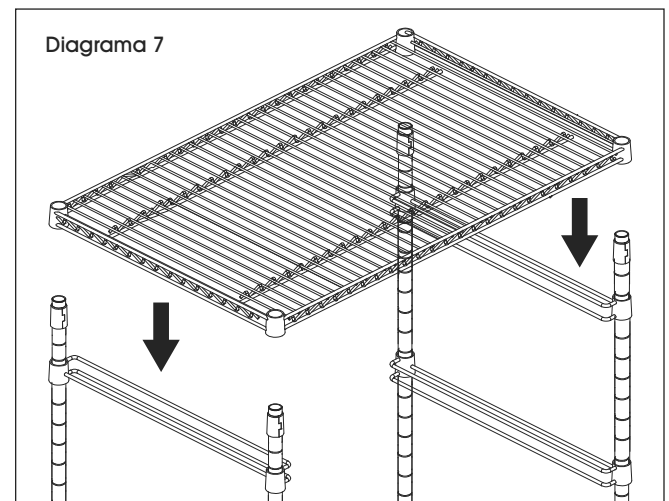

ULINE

800-295-5510

uline.mx

ULINE H-10768

CHARIOT DE RÉASSORTIMENT AVEC PROTECTION DES HAUTEUR DE 101,6 cm (40 po)

1-800-295-5510
uline.ca

OUTIL REQUIS



Maillet en caoutchouc

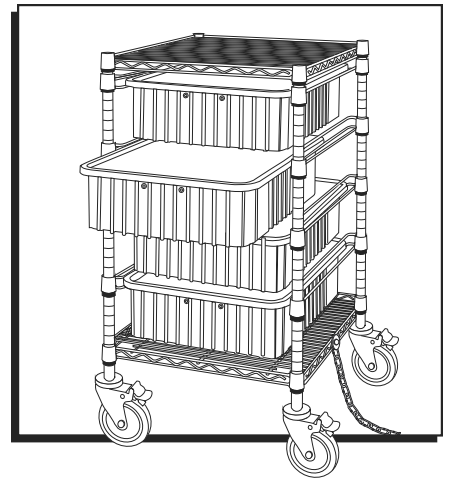

PIÈCES



Montant à deux
pièces x 4

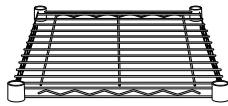

Tablette x 2

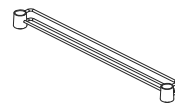

Glissière pour boîte x 8



Support de tablette
x 24 ensembles

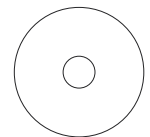

Grande
rondelle x 2

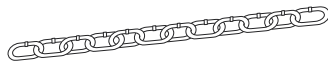

Chaîne de mise à la terre x 1



Boulon à tête
hexagonale x 1



Butoir circulaire x 4



Anneau de retenue x 16



Rondelle de blocage x 1



Écrou freiné x 1



Roulette
conductrice x 4

INSTALLATION DES ROULETTES

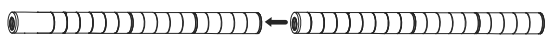

Figure 1

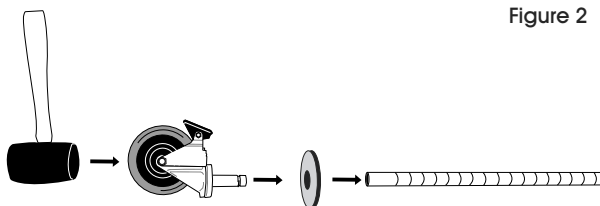

Figure 2

POUR INSTALLER LES ROULETTES

1. Connectez les montants en les vissant ensemble. (Voir Figure 1)
2. Assurez-vous que le montant est positionné comme illustré. (Voir Figure 2)
3. Engagez les freins de roue pour empêcher le mouvement des roulettes lors du montage. Utilisez un maillet en caoutchouc pour passer les embouts des roulettes à travers le butoir circulaire, puis dans les montants. (Voir Figure 2)

MONTAGE DE L'UNITÉ

1. Commencez par la tablette inférieure. Enclenchez les deux parties d'un support de tablette (la partie la plus large vers le bas) autour du montant à la rainure la plus basse où la tablette doit être placée. Glissez le support vers le haut ou vers le bas jusqu'à ce qu'il s'enclenche dans la rainure. Ajoutez un support de tablette à la même hauteur sur les montants restants. (Voir Figure 3)

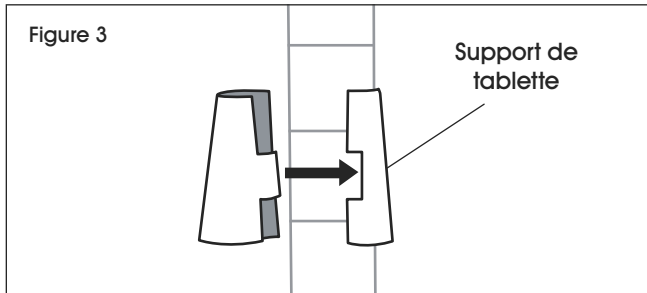

2. Glissez les montants dans la partie inférieure de la tablette jusqu'à ce que la tablette glisse fermement en place sur les supports. (Voir Figure 4)

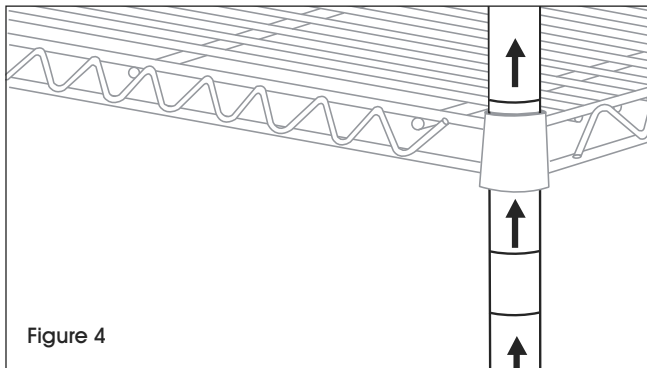

3. Placez l'unité à la verticale. À l'aide du maillet en caoutchouc, tapotez doucement sur la tablette vers le bas pour la fixer. (Voir Figure 5)

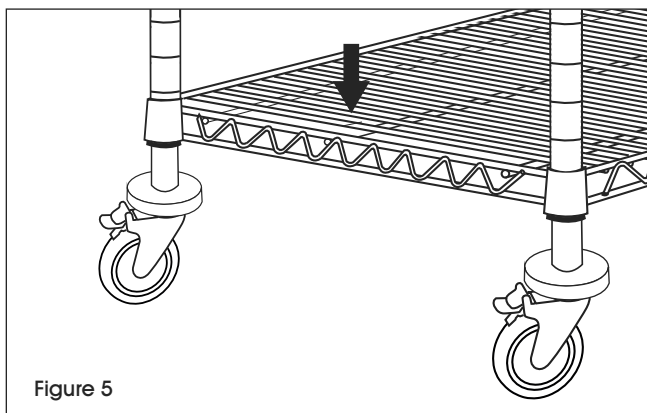

4. Installez les supports de tablette sur chaque montant au-dessus de la tablette inférieure. Assurez une distance de 6 po entre les deux pour avoir suffisamment d'espace pour les boîtes à diviser. Glissez les glissières pour boîte sur les montants de chaque côté de l'unité de rayonnage. Tapotez doucement les glissières pour boîte vers le bas pour les sécuriser. (Voir Figure 6)

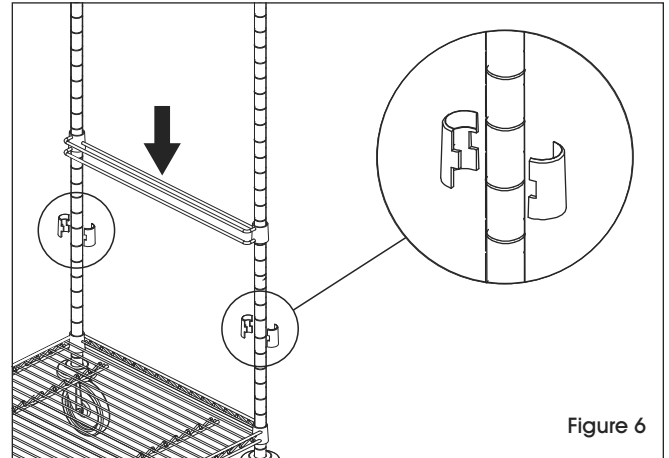

5. Répétez cette étape pour les autres glissières pour boîte en gardant un espace de 6 po entre chaque ensemble de supports de tablette.

6. Ajoutez un support de tablette au sommet de chaque montant. Installez la tablette supérieure sur les supports de tablette, puis tapotez doucement la tablette avec le maillet en caoutchouc. (Voir Figure 7)

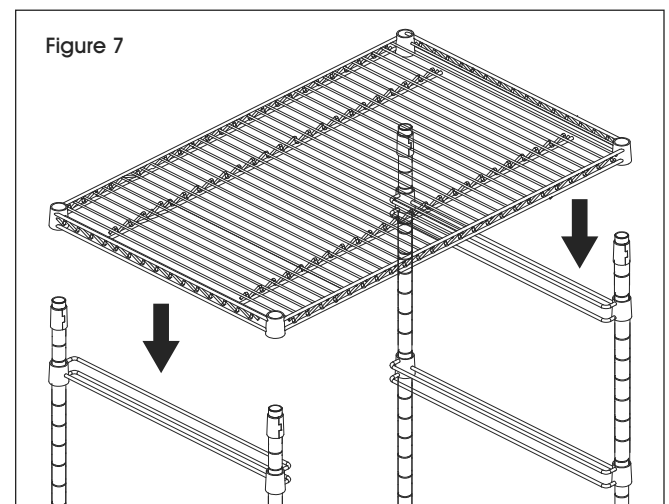

ULINE

1-800-295-5510
uline.ca