

# ULINE H-1077 MONARCH 1153<sup>®</sup> THREE LINE LABEL GUN

1-800-295-5510  
uline.com

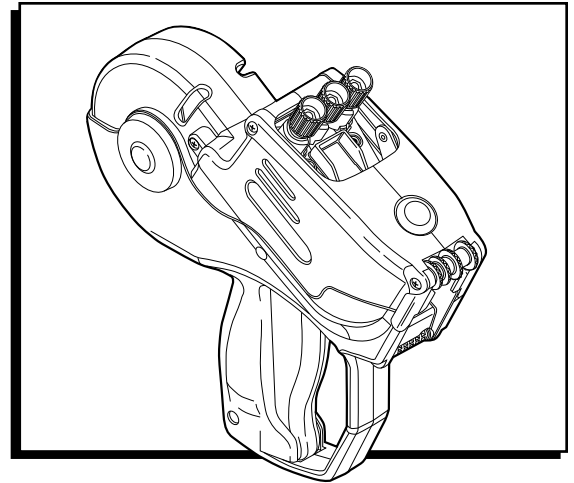

## OPERATION

### CHANGING THE INK ROLLER

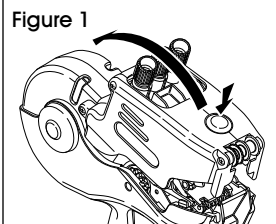

1. Push the release button and swing the cover open until it clicks. (See Figure 1)

 **NOTE:** Do not force the cover past the click position.

2. Push the release bar to release ink roller. (See Figure 2)

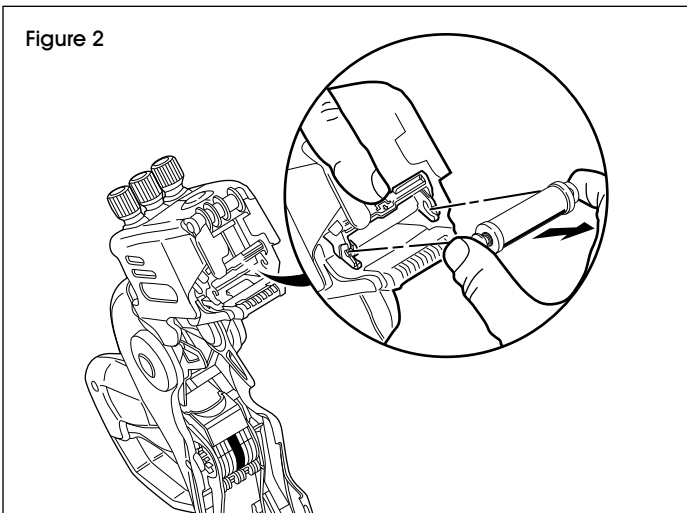

3. Hold the ink roller on each end, remove and discard.
4. Hold the new ink roller on each end and snap into place.

### SETTING PRINT CHARACTERS

1. Pull the knob out until the indicators are on the desired band. (See Figure 3)

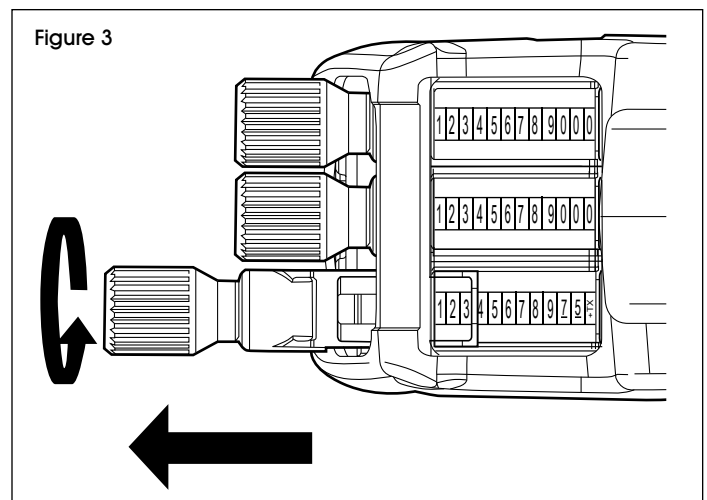

2. Turn the knob until the desired character appears black on a white background between the indicators. To print a blank, select the blank space for that band.
3. Repeat steps 1-2 for each band.
4. Push the knob in when done.

# OPERATION CONTINUED

## LOADING LABELS

1. Push the release button and swing the cover open until it clicks. (See Figure 4)

 **NOTE:** Do not force the cover past the click position.

2. For loading a new roll of labels, tear off and discard the first 10" of label and liner.
3. Peel the first 12 labels from liner and discard.
4. Place the label roll between the hubs and click into place. (See Figure 4)

 **NOTE:** Do not thread strip through any rollers.

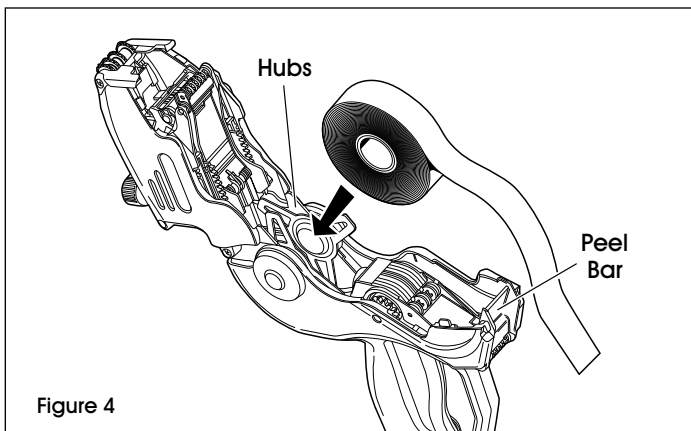

5. Drape the supply across the labeler and center it over the peel bar. The supply should hang out 6-7" past the peel bar.
6. Close the cover.
7. Squeeze and hold the trigger while feeding the label strip under the roller and into the large slot above the arrow until it stops/hits the back. (See Figure 5)

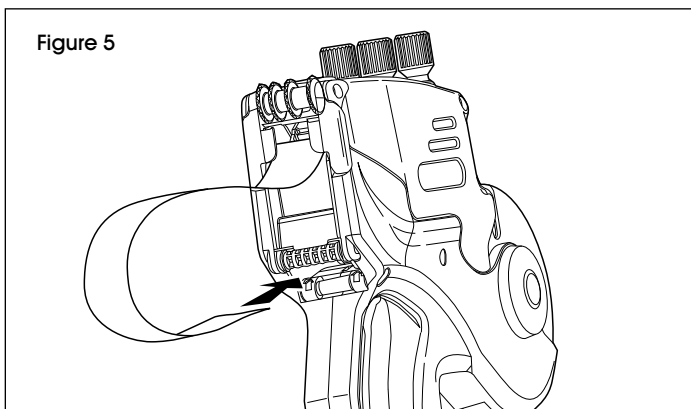

8. Hold the strip in place and squeeze the trigger eight times or until the label strip feeds through the rear exit.
9. Remove any loose labels.

## CLEARING LABEL JAMS, CLEANING AND LUBRICATION

1. Open the cover and remove the label roll.
2. Remove any loose labels from the inside of the labeler. (See Figure 6)

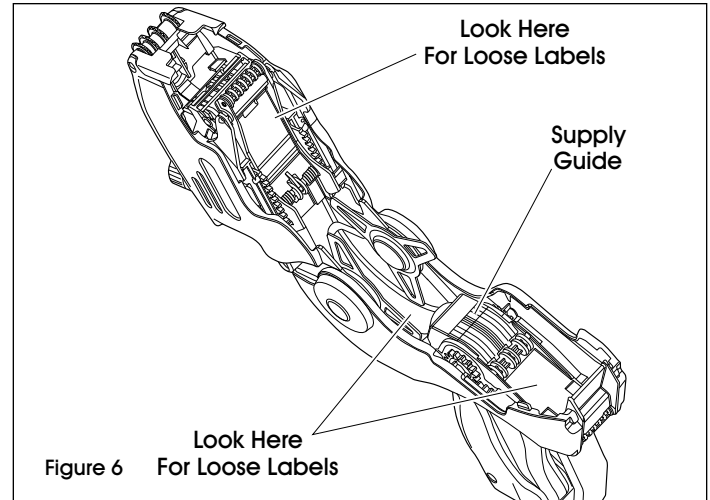

3. Pull up on the supply guide to expose the backing paper path and remove loose labels. (See Figure 7)

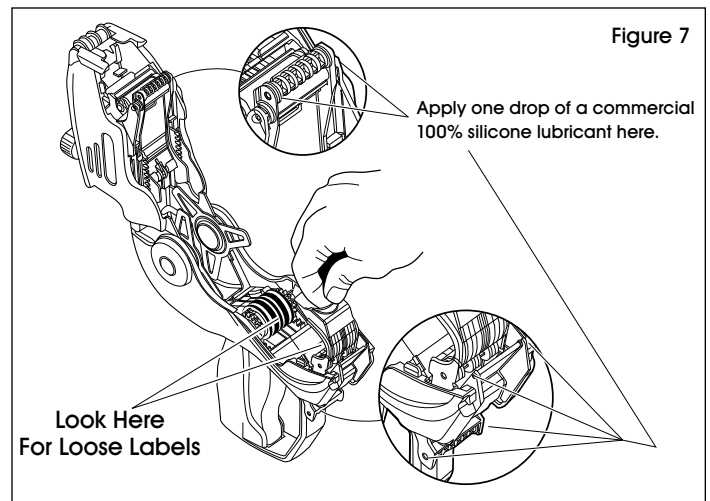

4. Snap the supply guide back into place.
5. Use a commercial adhesive solvent to clean adhesive buildup.
6. Remove the ink roller to expose the print bands and brush them off with a toothbrush.
7. Reload, then close the cover.

# CHARACTER KEY

**Regular Font (5 MM)  
3rd Line**

		KNOB POSITION												
		1	2	3	4	5	6	7	8	9	10	11	12	
1	1	1	2	3	4	5	6	7	8	9	0	\$	FOR	FOR
2	2	2	3	4	5	6	7	8	9	0	\$	FOR	FOR	FOR
3	3	3	4	5	6	7	8	9	0	\$	FOR	FOR	FOR	FOR
4	4	4	5	6	7	8	9	0	\$	FOR	FOR	FOR	FOR	FOR
5	5	5	6	7	8	9	0	\$	FOR	FOR	FOR	FOR	FOR	FOR
6	6	6	7	8	9	0	\$	FOR	FOR	FOR	FOR	FOR	FOR	FOR
7	7	7	8	9	0	\$	FOR	FOR	FOR	FOR	FOR	FOR	FOR	FOR
8	8	8	9	0	\$	FOR	FOR	FOR	FOR	FOR	FOR	FOR	FOR	FOR
9	9	9	0	\$	FOR	FOR	FOR	FOR	FOR	FOR	FOR	FOR	FOR	FOR
0	0	0	\$	FOR	FOR	FOR	FOR	FOR	FOR	FOR	FOR	FOR	FOR	FOR
\$	\$	\$	FOR	FOR	FOR	FOR	FOR	FOR	FOR	FOR	FOR	FOR	FOR	FOR
+	+	+	FOR	FOR	FOR	FOR	FOR	FOR	FOR	FOR	FOR	FOR	FOR	FOR
TX	TX	TX	FOR	FOR	FOR	FOR	FOR	FOR	FOR	FOR	FOR	FOR	FOR	FOR
DEP	DEP	DEP	FOR	FOR	FOR	FOR	FOR	FOR	FOR	FOR	FOR	FOR	FOR	FOR
OFF	OFF	OFF	FOR	FOR	FOR	FOR	FOR	FOR	FOR	FOR	FOR	FOR	FOR	FOR
SET	SET	SET	FOR	FOR	FOR	FOR	FOR	FOR	FOR	FOR	FOR	FOR	FOR	FOR
CASE	CASE	CASE	FOR	FOR	FOR	FOR	FOR	FOR	FOR	FOR	FOR	FOR	FOR	FOR
BOX	BOX	BOX	FOR	FOR	FOR	FOR	FOR	FOR	FOR	FOR	FOR	FOR	FOR	FOR
PKG	PKG	PKG	FOR	FOR	FOR	FOR	FOR	FOR	FOR	FOR	FOR	FOR	FOR	FOR
PAIR	PAIR	PAIR	FOR	FOR	FOR	FOR	FOR	FOR	FOR	FOR	FOR	FOR	FOR	FOR
DOZ	DOZ	DOZ	FOR	FOR	FOR	FOR	FOR	FOR	FOR	FOR	FOR	FOR	FOR	FOR
YARD	YARD	YARD	FOR	FOR	FOR	FOR	FOR	FOR	FOR	FOR	FOR	FOR	FOR	FOR
FOOT	FOOT	FOOT	FOR	FOR	FOR	FOR	FOR	FOR	FOR	FOR	FOR	FOR	FOR	FOR
EACH	EACH	EACH	FOR	FOR	FOR	FOR	FOR	FOR	FOR	FOR	FOR	FOR	FOR	FOR
LB	LB	LB	FOR	FOR	FOR	FOR	FOR	FOR	FOR	FOR	FOR	FOR	FOR	FOR

**NOT INDICATIVE OF  
FONT SIZE AND STYLE**

**Regular Font (3 MM)  
1st and 2nd Line**

		KNOB POSITION												
		1	2	3	4	5	6	7	8	9	10	11	12	
1	1	1	2	3	4	5	6	7	8	9	0	\$	FOR	FOR
2	2	2	3	4	5	6	7	8	9	0	\$	FOR	FOR	FOR
3	3	3	4	5	6	7	8	9	0	\$	FOR	FOR	FOR	FOR
4	4	4	5	6	7	8	9	0	\$	FOR	FOR	FOR	FOR	FOR
5	5	5	6	7	8	9	0	\$	FOR	FOR	FOR	FOR	FOR	FOR
6	6	6	7	8	9	0	\$	FOR	FOR	FOR	FOR	FOR	FOR	FOR
7	7	7	8	9	0	\$	FOR	FOR	FOR	FOR	FOR	FOR	FOR	FOR
8	8	8	9	0	\$	FOR	FOR	FOR	FOR	FOR	FOR	FOR	FOR	FOR
9	9	9	0	\$	FOR	FOR	FOR	FOR	FOR	FOR	FOR	FOR	FOR	FOR
0	0	0	\$	FOR	FOR	FOR	FOR	FOR	FOR	FOR	FOR	FOR	FOR	FOR
\$	\$	\$	FOR	FOR	FOR	FOR	FOR	FOR	FOR	FOR	FOR	FOR	FOR	FOR
+	+	+	FOR	FOR	FOR	FOR	FOR	FOR	FOR	FOR	FOR	FOR	FOR	FOR
TX	TX	TX	FOR	FOR	FOR	FOR	FOR	FOR	FOR	FOR	FOR	FOR	FOR	FOR
DEP	DEP	DEP	FOR	FOR	FOR	FOR	FOR	FOR	FOR	FOR	FOR	FOR	FOR	FOR
OFF	OFF	OFF	FOR	FOR	FOR	FOR	FOR	FOR	FOR	FOR	FOR	FOR	FOR	FOR
SET	SET	SET	FOR	FOR	FOR	FOR	FOR	FOR	FOR	FOR	FOR	FOR	FOR	FOR
CASE	CASE	CASE	FOR	FOR	FOR	FOR	FOR	FOR	FOR	FOR	FOR	FOR	FOR	FOR
BOX	BOX	BOX	FOR	FOR	FOR	FOR	FOR	FOR	FOR	FOR	FOR	FOR	FOR	FOR
PKG	PKG	PKG	FOR	FOR	FOR	FOR	FOR	FOR	FOR	FOR	FOR	FOR	FOR	FOR
PAIR	PAIR	PAIR	FOR	FOR	FOR	FOR	FOR	FOR	FOR	FOR	FOR	FOR	FOR	FOR
DOZ	DOZ	DOZ	FOR	FOR	FOR	FOR	FOR	FOR	FOR	FOR	FOR	FOR	FOR	FOR
YARD	YARD	YARD	FOR	FOR	FOR	FOR	FOR	FOR	FOR	FOR	FOR	FOR	FOR	FOR
FOOT	FOOT	FOOT	FOR	FOR	FOR	FOR	FOR	FOR	FOR	FOR	FOR	FOR	FOR	FOR
EACH	EACH	EACH	FOR	FOR	FOR	FOR	FOR	FOR	FOR	FOR	FOR	FOR	FOR	FOR
LB	LB	LB	FOR	FOR	FOR	FOR	FOR	FOR	FOR	FOR	FOR	FOR	FOR	FOR



1-800-295-5510  
uline.com

# ULINE H-1077 ETIQUETADORA MONARCH 1153® DE TRES LÍNEAS

800-295-5510  
uline.mx

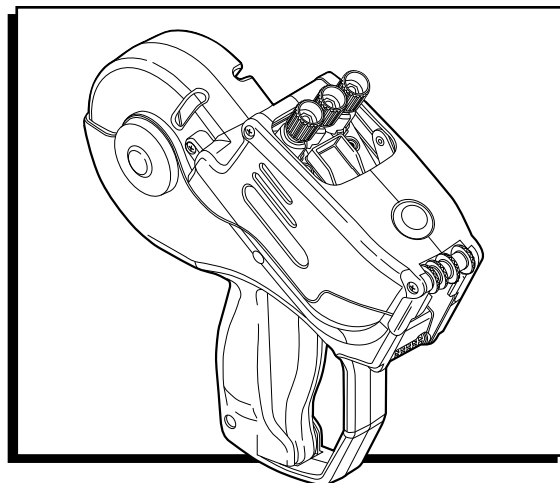

## FUNCIONAMIENTO

### CAMBIAR EL RODILLO DE TINTA

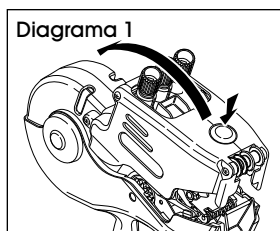

1. Presione el botón de liberación y abra la cubierta hasta que haga clic. (Vea Diagrama 1)

 **NOTA:** No fuerce la cubierta después de pasar la posición del clic.

2. Presione la barra para liberar el rodillo de tinta. (Vea Diagrama 2)

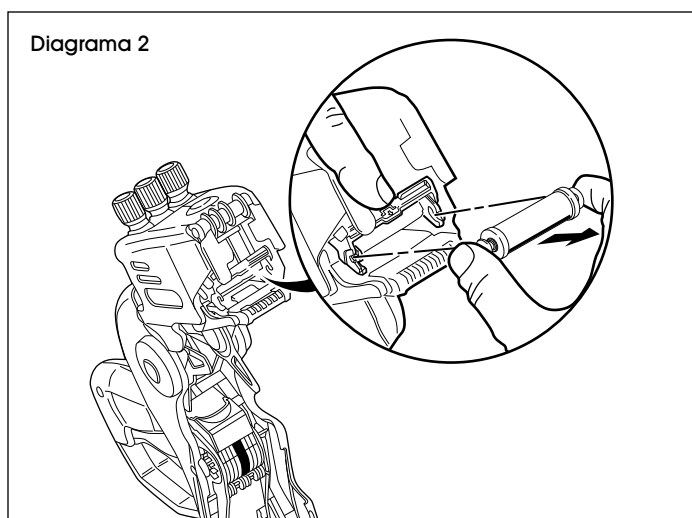

3. Sostenga el rodillo de tinta en cada extremo, retire y deseche.
4. Sostenga el nuevo rodillo de tinta en cada extremo y ajuste hasta que haga clic en su lugar.

### CONFIGURAR CARACTERES DE IMPRESIÓN

1. Jale la perilla hasta que los indicadores estén sobre la banda deseada. (Vea Diagrama 3)

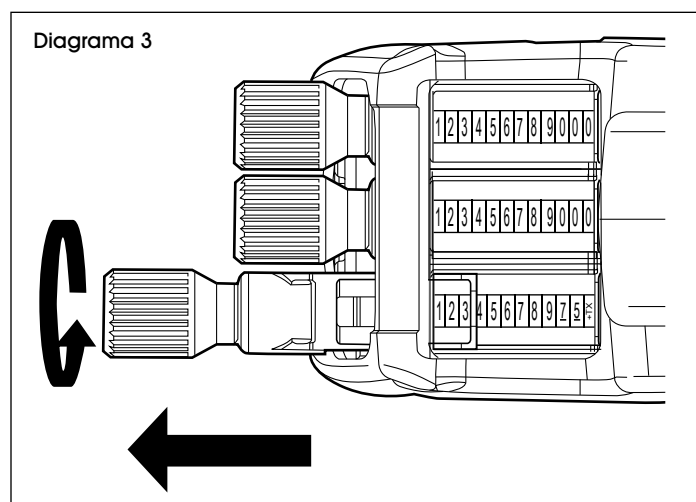

2. Gire la perilla hasta que el caracter deseado aparezca negro sobre fondo blanco entre los indicadores. Para imprimir un espacio blanco, seleccione el espacio blanco en esa banda.
3. Repita los pasos 1-2 para cada banda.
4. Presione la perilla cuando termine.

# CONTINUACIÓN DE FUNCIONAMIENTO

## CARGAR ETIQUETAS

1. Presione el botón de liberación y abra la cubierta hasta que haga clic. (Vea Diagrama 4)

 **NOTA:** No fuerce la cubierta después de pasar la posición del clic.

2. Para cargar un nuevo rollo de etiquetas, despegue y deseche los primeros 25 cm (10") de etiquetas y respaldo.
3. Despegue las primeras 12 etiquetas del respaldo y deséchelas.
4. Coloque el rollo de etiquetas entre los núcleos y presione hasta hacer clic. (Vea Diagrama 4)

 **NOTA:** No haga pasar la tira de etiquetas a través de ninguno de los rodillos.

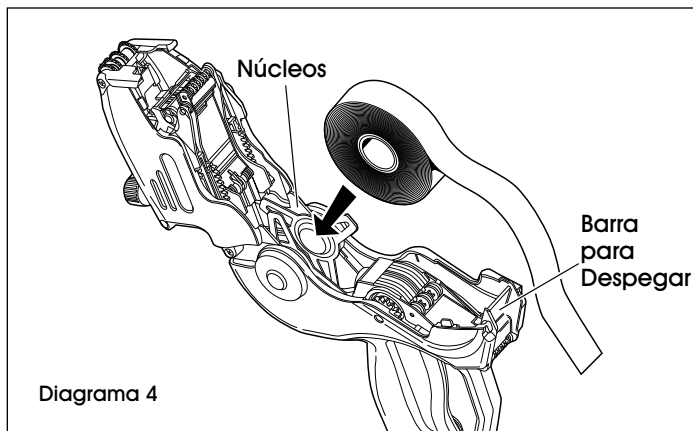

5. Deje colgando un tramo del suministro a través de la etiquetadora y céntralo sobre la barra para despegar. El tramo de suministro deberá colgar 13-15 cm (6-7") pasando la barra para despegar.
6. Cierre la cubierta.
7. Apriete y sostenga el gatillo mientras alimenta la tira de etiquetas debajo del rodillo y dentro de la ranura grande arriba de la flecha hasta que tope en la parte posterior. (Vea Diagrama 5)

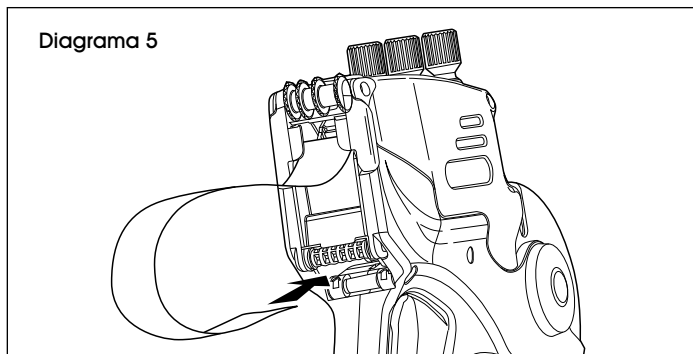

8. Mantenga la tira en su lugar y apriete el gatillo ocho veces o hasta que la tira de etiquetas salga por la parte posterior.
9. Retire cualquier etiqueta suelta.

## DESPEJAR ATASCOS DE ETIQUETAS, LIMPIEZA Y LUBRICACIÓN

1. Abra la cubierta y retire el rollo de etiquetas.
2. Retire cualquier etiqueta suelta del interior de la etiquetadora. (Vea Diagrama 6)

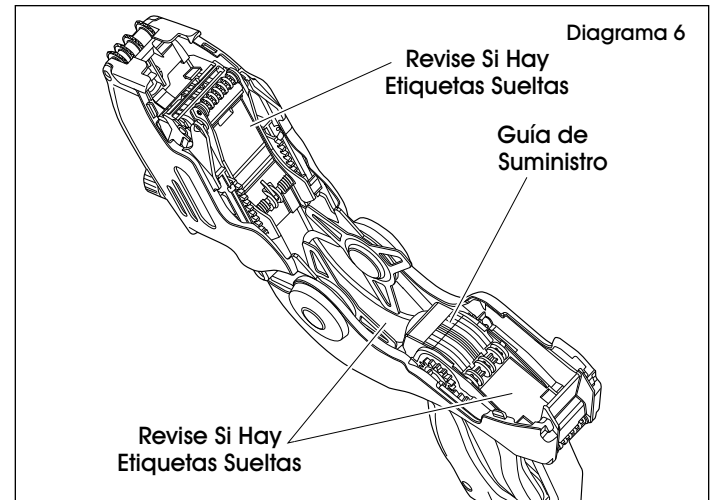

3. Jale hacia arriba la guía de suministro para exponer el trayecto del respaldo de papel y retire las etiquetas sueltas. (Vea Diagrama 7)

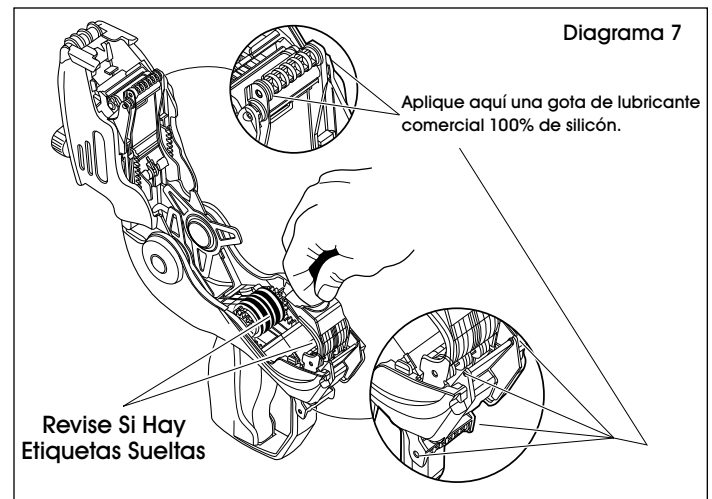

4. Coloque hasta que haga clic la guía de suministro de regreso a su lugar.
5. Utilice un solvente de adhesivo comercial para limpiar la acumulación de adhesivo.
6. Retire el rodillo de tinta para exponer las bandas de impresión y cepíllelas con un cepillo dental.
7. Recargue, luego cierre la cubierta.

# CLAVE DE CARACTERES

**Letra Regular (5 MM)  
3a. Línea**

POSICIÓN DE LA PERILLA											
1	2	3	4	5	6	7	8	9	10	11	12
1	1	1	1	.	.	.	1	1	1	1	1
2	2	2	2	1	1	1	2	2	2	2	2
3	3	3	3	2	2	2	3	3	3	3	3
4	4	4	4	3	3	3	4	4	4	4	4
5	5	5	5	4	4	4	5	5	5	5	5
6	6	6	6	5	5	5	6	6	6	6	6
7	7	7	7	6	6	6	7	7	7	7	7
8	8	8	8	7	7	7	8	8	8	8	8
9	9	9	9	8	8	8	9	9	9	9	9
0	0	0	0	9	9	9	0	0	0	0	0
\$	\$	\$	\$	\$	\$	\$	+	+	+	+	+
FOR	FOR	FOR	FOR	FOR	FOR	FOR	TX	TX	TX	TX	TX
/	/	/	/	/	/	/	☺	☺	☺	☺	☺
							DEP	DEP	DEP	DEP	DEP
							OFF	OFF	OFF	OFF	OFF
							SET	SET	SET	SET	SET
							BOX	BOX	BOX	BOX	BOX
							PKG	PKG	PKG	PKG	PKG
							PAIR	PAIR	PAIR	PAIR	PAIR
							DOZ	DOZ	DOZ	DOZ	DOZ
							YARD	YARD	YARD	YARD	YARD
							FOOT	FOOT	FOOT	FOOT	FOOT
							EACH	EACH	EACH	EACH	EACH
							LB	LB	LB	LB	LB

**NO INDICA EL TAMAÑO  
Y ESTILO DE LETRA**

**Letra Regular (3 MM)  
1a. y 2a. Línea**

POSICIÓN DE LA PERILLA											
1	2	3	4	5	6	7	8	9	10	11	12
.	.	.	.	.	.	.	.	.	.	.	.
1	1	1	1	1	1	1	1	1	1	1	1
2	2	2	2	2	2	2	2	2	2	2	2
3	3	3	3	3	3	3	3	3	3	3	3
4	4	4	4	4	4	4	4	4	4	4	4
5	5	5	5	5	5	5	5	5	5	5	5
6	6	6	6	6	6	6	6	6	6	6	6
7	7	7	7	7	7	7	7	7	7	7	7
8	8	8	8	8	8	8	8	8	8	8	8
9	9	9	9	9	9	9	9	9	9	9	9
0	0	0	0	0	0	0	0	0	0	0	0
\$	\$	\$	\$	\$	\$	\$	\$	\$	\$	\$	\$
FOR	FOR	FOR	FOR	FOR	FOR	FOR	FOR	FOR	FOR	FOR	FOR
WAS	WAS	WAS	WAS	WAS	WAS	WAS	WAS	WAS	WAS	WAS	WAS
☺	☺	☺	☺	☺	☺	☺	☺	☺	☺	☺	☺
/	/	/	/	/	/	/	/	/	/	/	/
.	.	.	.	.	.	.	.	.	.	.	.



800-295-5510  
uline.mx

**ULINE** H-1077

**MONARCH 1153<sup>MD</sup> –  
PISTOLET À ÉTIQUETTES –  
TROIS LIGNES**

1 800 295-5510  
uline.ca

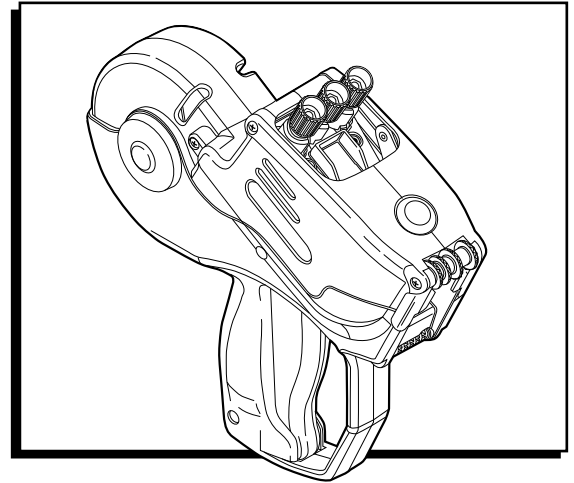

## FONCTIONNEMENT

### CHANGEMENT DU ROULEAU ENCREUR

Figure 1

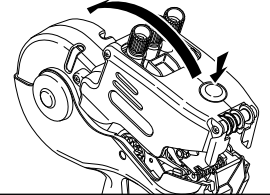

1. Poussez le bouton de dégagement et ouvrez le couvercle jusqu'à entendre un déclic. (Voir Figure 1)



**REMARQUE :** Ne forcez pas le couvercle au-delà de la position du déclic.

2. Poussez le levier de déclenchement pour libérer le rouleau encreur. (Voir Figure 2)

Figure 2

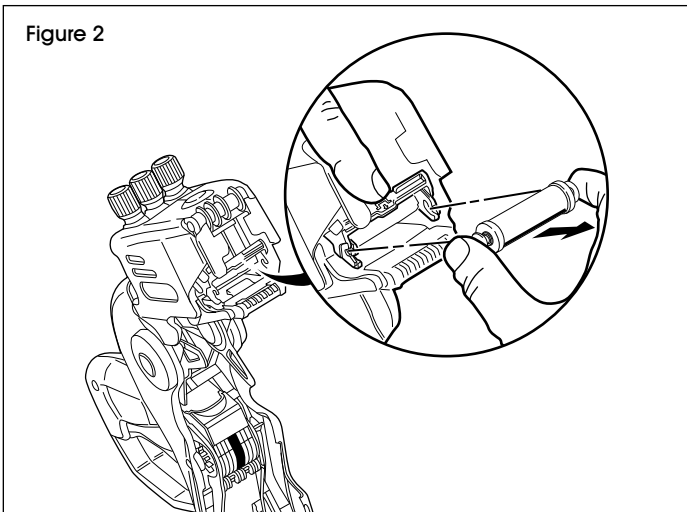

3. Tenez le rouleau encreur par chaque extrémité, retirez-le puis jetez-le.
4. Tenez le nouveau rouleau encreur par chaque extrémité et enclenchez-le en position.

### RÉGLAGE DES CARACTÈRES D'IMPRESSION

1. Tirez sur le bouton jusqu'à ce que les indicateurs soient sur la bande désirée. (Voir Figure 3)

Figure 3

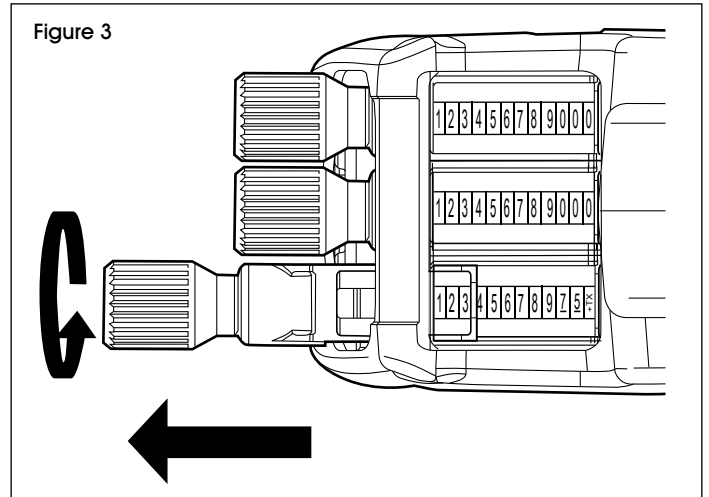

2. Tournez le bouton jusqu'à ce que le caractère souhaité apparaisse en noir sur fond blanc entre les indicateurs. Pour imprimer un caractère vierge, sélectionnez l'espace vide pour cette bande.
3. Répétez les étapes 1 et 2 pour chaque bande.
4. Enfoncez le bouton après avoir fini.

# FONCTIONNEMENT SUITE

## CHARGEMENT DES ÉTIQUETTES

1. Poussez le bouton de dégagement et ouvrez le couvercle jusqu'à entendre un déclic. (Voir Figure 4)

 **REMARQUE :** Ne forcez pas le couvercle au-delà de la position du déclic.

2. Pour charger un nouveau rouleau d'étiquettes, déchirez et jetez les premiers 25 cm (10 po) d'étiquettes et de doublure.
3. Décollez les 12 premières étiquettes de la doublure et jetez-les.
4. Placez le rouleau d'étiquettes entre les moyeux et enclenchez-le en position. (Voir Figure 4)

 **REMARQUE :** N'enfilez pas de bande au travers des rouleaux.

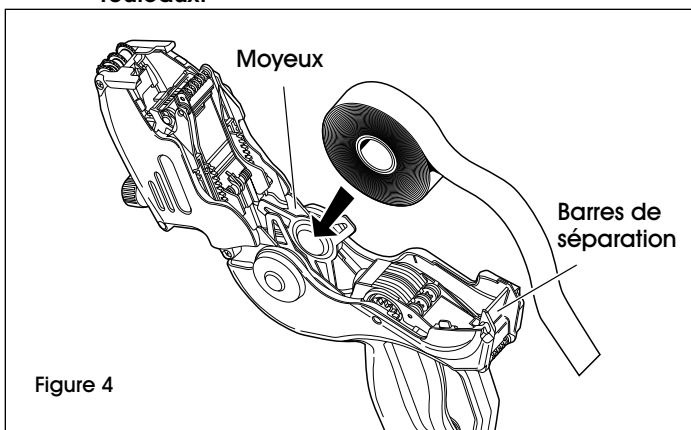

5. Déposez la bande sur l'étiqueteuse et centrez-la sur la barre de séparation. La bande devrait dépasser de 15 à 18 cm (6 à 7 po) au-delà de la barre de séparation.
6. Fermez le couvercle.
7. Pressez et maintenez la détente enfoncée tout en alimentant la bande d'étiquettes sous le rouleau et jusque dans la grande fente au-dessus de la flèche, jusqu'à ce qu'elle s'arrête ou atteigne l'arrière. (Voir Figure 5)

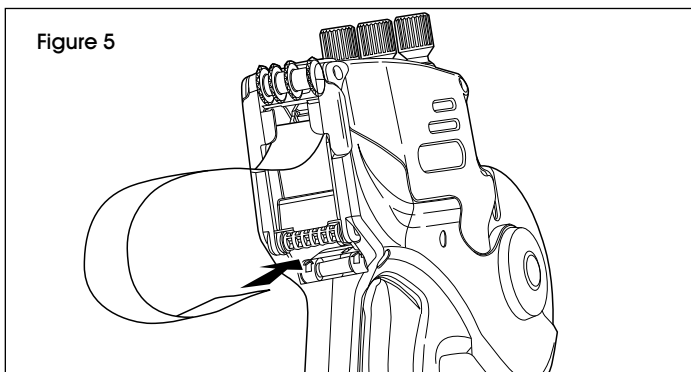

8. Maintenez la bande en place et appuyez sur la détente huit fois ou jusqu'à ce que la bande d'étiquettes émerge de la sortie arrière.
9. Enlevez toute étiquette lâche.

## DÉPANNAGE DES BOURRAGES, NETTOYAGE ET LUBRIFICATION

1. Ouvrez le couvercle et retirez le rouleau d'étiquettes.
2. Enlevez toute étiquette lâche à l'intérieur de l'étiqueteuse. (Voir Figure 6)

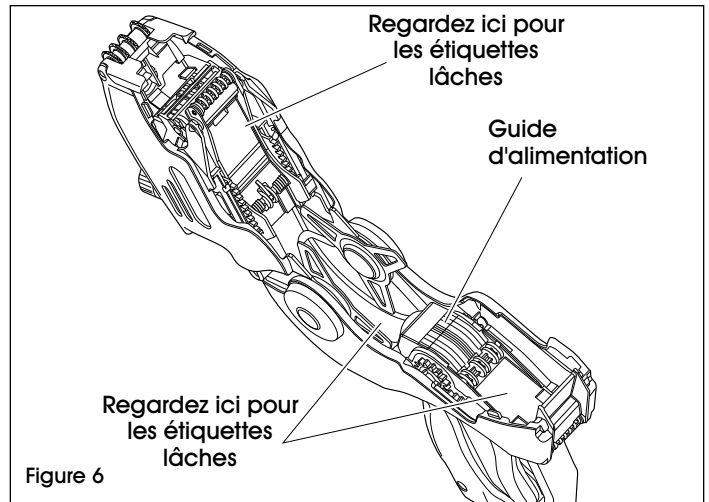

3. Tirez sur le guide d'alimentation pour révéler le chemin de la doublure et retirer les étiquettes lâches. (Voir Figure 7)

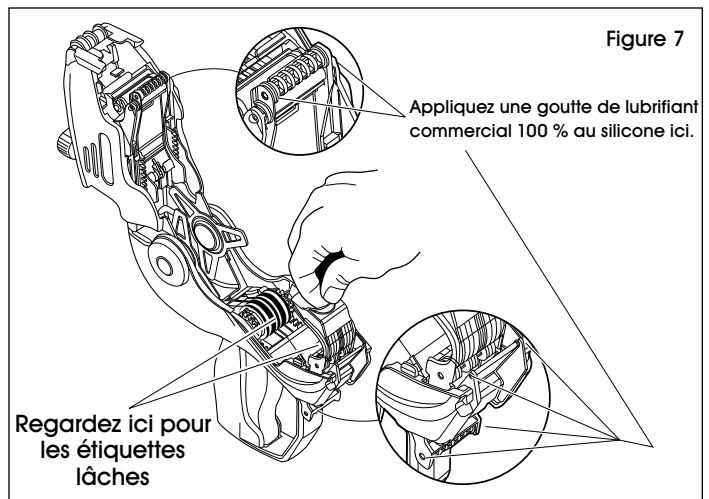

4. Encliquez le guide d'alimentation dans sa position originale.
5. Utilisez un solvant commercial pour adhésif afin de nettoyer l'accumulation d'adhésif.
6. Retirez le rouleau encreur pour exposer les bandes d'impression, et nettoyez-les avec une brosse à dents.
7. Rechargez, puis fermez le couvercle.



# CARACTÈRES

## Police régulière (5 mm) Ligne 3

POSITION DU BOUTON												+TX +DEP OFF	SET	CASE	BOX	PKG	PAIR	DOZ	YARD	FOOT	EACH	LB
1	1	2	3	4	5	6	7	8	9	0	1	2	3	4	5	6	7	8	9	0	TX	OFF
1	2	3	4	5	6	7	8	9	0	1	2	3	4	5	6	7	8	9	0	TX	OFF	TX
1	2	3	4	5	6	7	8	9	0	1	2	3	4	5	6	7	8	9	0	TX	OFF	TX
1	2	3	4	5	6	7	8	9	0	1	2	3	4	5	6	7	8	9	0	TX	OFF	TX
1	2	3	4	5	6	7	8	9	0	1	2	3	4	5	6	7	8	9	0	TX	OFF	TX
1	2	3	4	5	6	7	8	9	0	1	2	3	4	5	6	7	8	9	0	TX	OFF	TX
1	2	3	4	5	6	7	8	9	0	1	2	3	4	5	6	7	8	9	0	TX	OFF	TX
1	2	3	4	5	6	7	8	9	0	1	2	3	4	5	6	7	8	9	0	TX	OFF	TX
1	2	3	4	5	6	7	8	9	0	1	2	3	4	5	6	7	8	9	0	TX	OFF	TX
1	2	3	4	5	6	7	8	9	0	1	2	3	4	5	6	7	8	9	0	TX	OFF	TX
1	2	3	4	5	6	7	8	9	0	1	2	3	4	5	6	7	8	9	0	TX	OFF	TX
1	2	3	4	5	6	7	8	9	0	1	2	3	4	5	6	7	8	9	0	TX	OFF	TX

**PAS REPRÉSENTATIF DE LA TAILLE  
OU DU STYLE DE POLICE**

## Police régulière (3 mm) Lignes 1 et 2

POSITION DU BOUTON												FOR	WAS	FOR	WAS	FOR	WAS	FOR	WAS	FOR	WAS	FOR	WAS
1	1	2	3	4	5	6	7	8	9	0	1	2	3	4	5	6	7	8	9	0	1	2	
1	2	3	4	5	6	7	8	9	0	1	2	3	4	5	6	7	8	9	0	1	2	3	
1	2	3	4	5	6	7	8	9	0	1	2	3	4	5	6	7	8	9	0	1	2	3	
1	2	3	4	5	6	7	8	9	0	1	2	3	4	5	6	7	8	9	0	1	2	3	
1	2	3	4	5	6	7	8	9	0	1	2	3	4	5	6	7	8	9	0	1	2	3	
1	2	3	4	5	6	7	8	9	0	1	2	3	4	5	6	7	8	9	0	1	2	3	
1	2	3	4	5	6	7	8	9	0	1	2	3	4	5	6	7	8	9	0	1	2	3	
1	2	3	4	5	6	7	8	9	0	1	2	3	4	5	6	7	8	9	0	1	2	3	
1	2	3	4	5	6	7	8	9	0	1	2	3	4	5	6	7	8	9	0	1	2	3	
1	2	3	4	5	6	7	8	9	0	1	2	3	4	5	6	7	8	9	0	1	2	3	
1	2	3	4	5	6	7	8	9	0	1	2	3	4	5	6	7	8	9	0	1	2	3	
1	2	3	4	5	6	7	8	9	0	1	2	3	4	5	6	7	8	9	0	1	2	3	
1	2	3	4	5	6	7	8	9	0	1	2	3	4	5	6	7	8	9	0	1	2	3	

