

# ULINE H-10825 BAKERY DISPLAY CASE

1-800-295-5510  
 uline.com

## TOOLS NEEDED



Allen Wrench  
 (included)



Mini Wrench  
 (included)



Two Person Assembly  
 Recommended

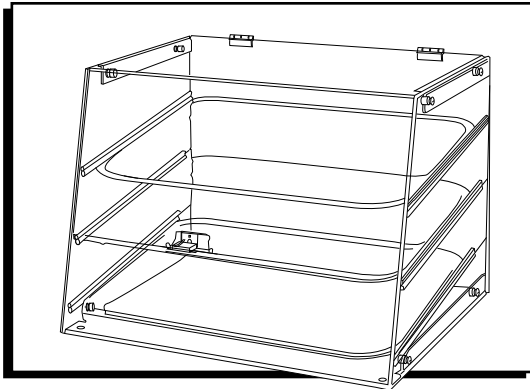

## PARTS

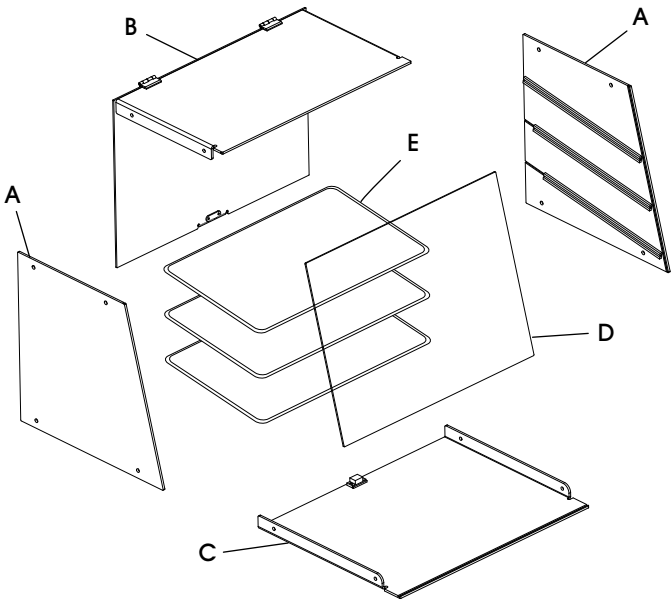

### PARTS

#	DESCRIPTION	QTY.
A	Side Panel with Angled Front	2
B	Hinged Top and Back	1
C	Base	1
D	Front Panel	1
E	Tray	3
F	Bolt	8
G	Nut	8

### Hardware Kit

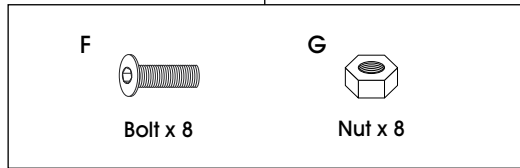

## ASSEMBLY



**NOTE:** Do not overtighten bolts. Once all pieces are assembled, lightly tighten all bolts to ensure pieces are snug and case is stable.

1. Place base (C) with rubber feet down, magnet facing away. (See Figure 1)
2. Attach side panels (A) to base with slanted edge facing front, away from magnet. (See Figure 1)



**NOTE:** Base (C) has a lip on both sides. Attach side panels (A) on the outside of the lip using nuts and bolts.



**NOTE:** Bolts should be on the outside facing in, nuts on the inside.

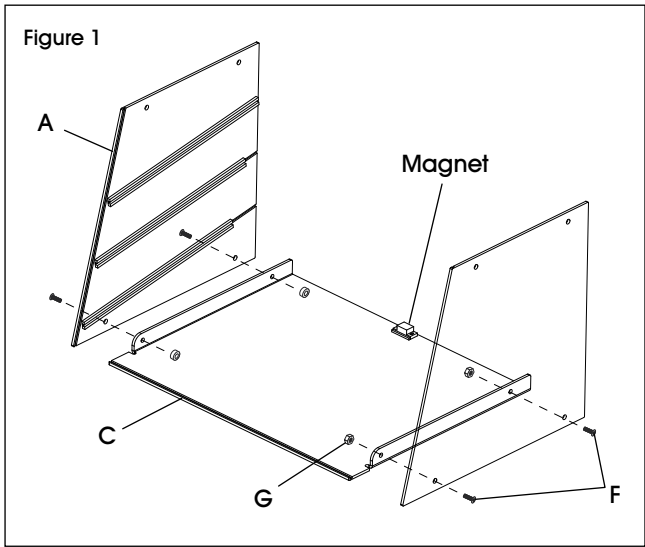

# ASSEMBLY CONTINUED

- With two people, slide front panel (D) into top of channels on each side panel (A) to form the front of case. (See Figure 2)

 **NOTE:** Front panel (D) should slide through the side channels all the way to the bottom, where it will rest in another channel on base (C).

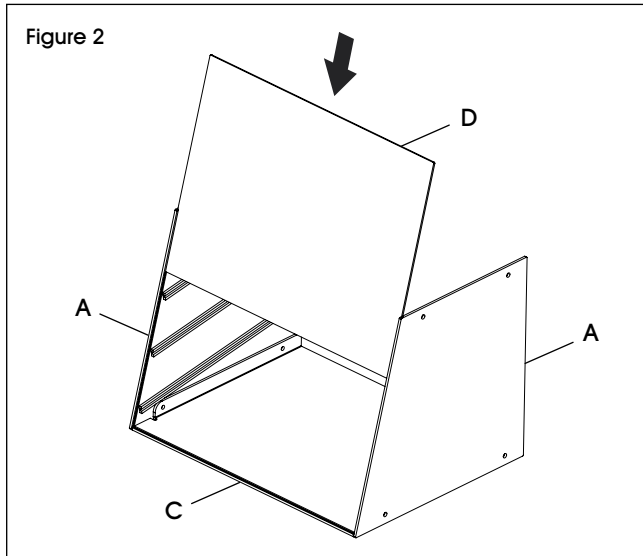

- Fit hinged top and back (B) onto top of case with hinged door covering the back. (See Figure 3)

 **NOTE:** Have one person hold side and front panels while second person fits hinged top and back onto case.

 **NOTE:** Magnets should match up on the hinged door and the base (C).

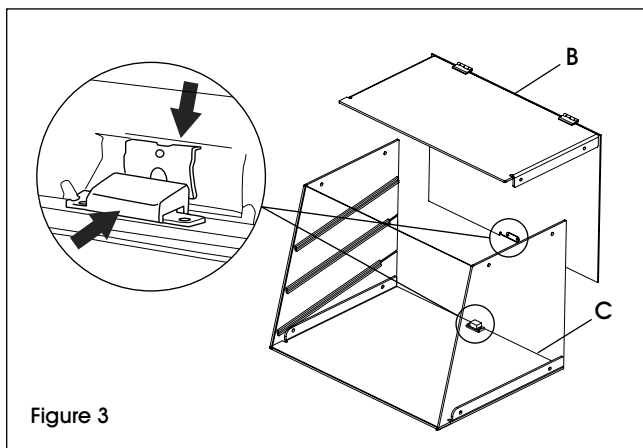

- Align channel in hinged top and back (B) with front (D) to secure front of the case. Front panel (D) should fit securely into channels on all four edges. (See Figure 4)

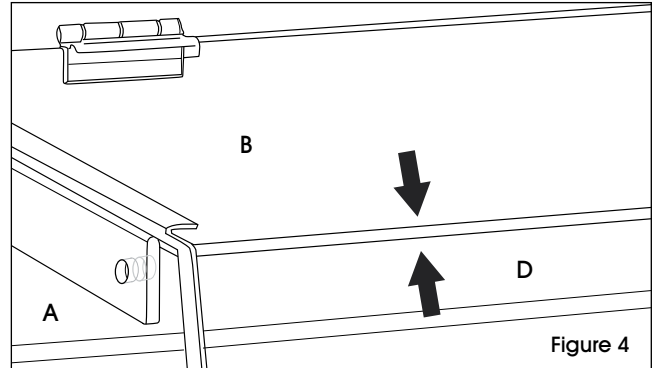

 **NOTE:** Side panels (A) should be on the outside of the top panel (B). Secure with bolts (F) on the outside and nuts (G) on the inside. (See Figure 5)

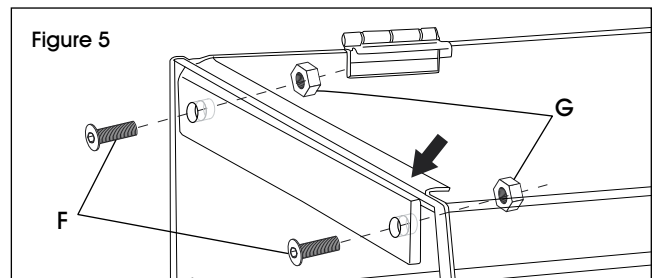

- Open hinged door and slide in three trays (E). (See Figure 6)

 **NOTE:** Lightly tighten all screws to ensure pieces are snug and case is stable. Do not over-tighten.

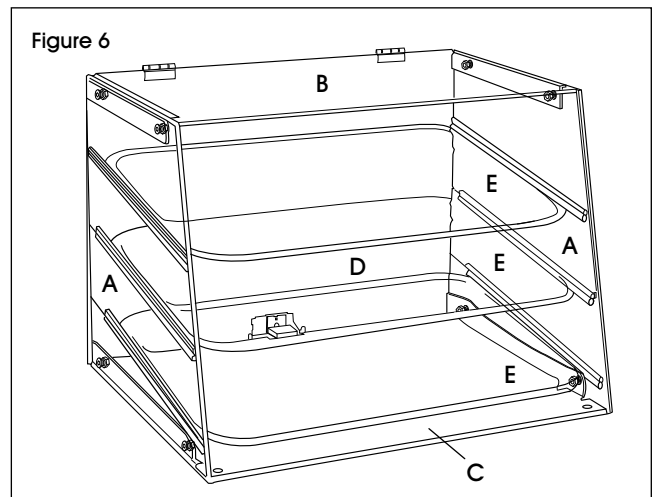

**ULINE**

1-800-295-5510  
uline.com

# ULINE H-10825

## EXHIBIDOR PARA PANADERÍA

800-295-5510  
uline.mx

### HERRAMIENTAS NECESARIAS



Llave Allen  
(incluida)



Minillave  
(incluida)



Se Recomienda Ensamblar  
entre Dos Personas

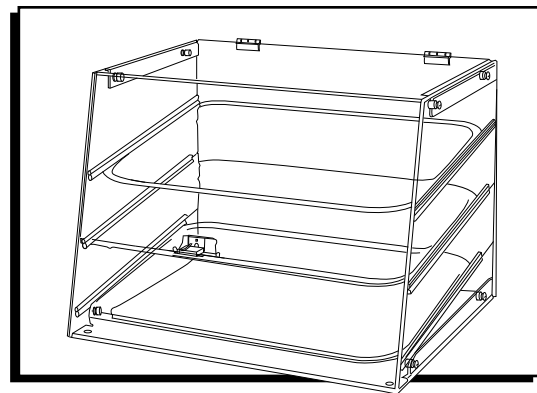

## PARTES

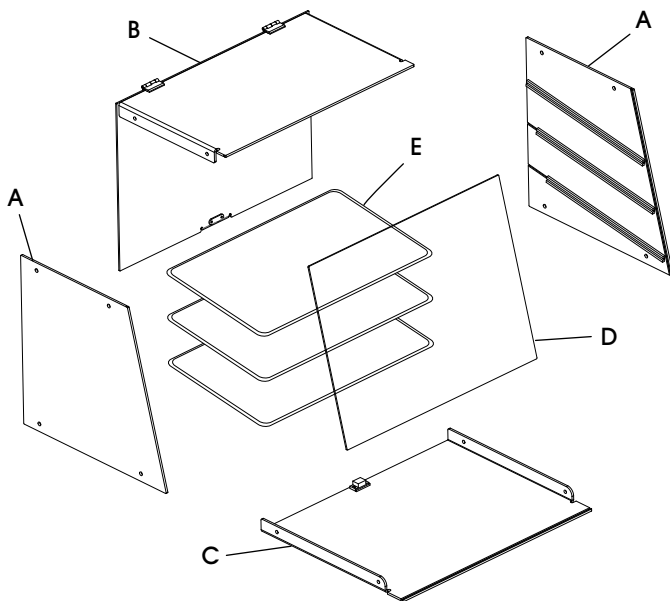

### PARTES

#	DESCRIPCIÓN	CANT.
A	Panel Lateral con Frente en Ángulo	2
B	Parte Superior y Posterior con Bisagras	1
C	Base	1
D	Panel Frontal	1
E	Charola	3
F	Perno	8
G	Tuerca	8

Kit de Tornillería



## ENSAMBLE



**NOTA:** No apriete demasiado los pernos. Una vez que todas las piezas estén ensambladas, apriete ligeramente todos los pernos para asegurar que todas las piezas queden ajustadas y el exhibidor quede estable.

1. Coloque la base (C) con las patas de caucho hacia abajo y el imán en dirección contraria. (Vea Diagrama 1)
2. Fije los paneles laterales (A) a la base con el borde inclinado volteado hacia al frente, en dirección contraria al imán. (Vea Diagrama 1)



**NOTA:** La base (C) tiene un reborde en ambos lados. Fije los paneles laterales (A) en el exterior del reborde utilizando tuercas y pernos.



**NOTA:** Los pernos deben estar en el exterior hacia adentro, las tuercas en el interior.

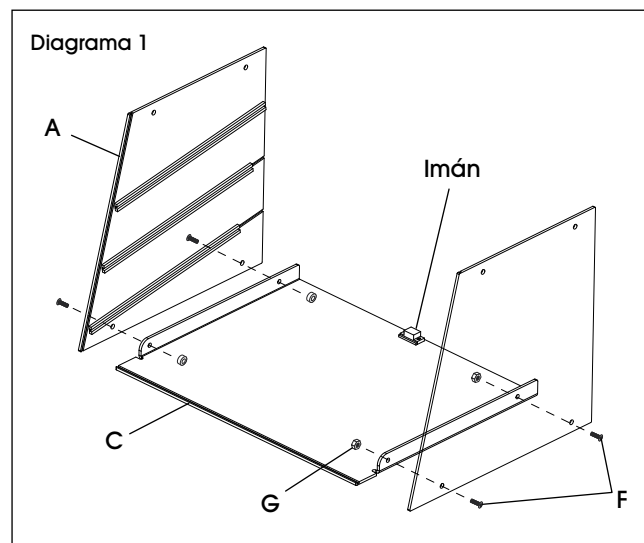

## CONTINUACIÓN DEL ENSAMBLE

3. Entre dos personas, deslicen el panel frontal (D) en la parte superior de los canales en cada lado de los paneles (A) para formar el frente del exhibidor. (Vea Diagrama 2)

 **NOTA:** El panel frontal (D) debe deslizarse a través de los canales laterales hasta llegar al fondo, donde descansará sobre un canal de la base (C).

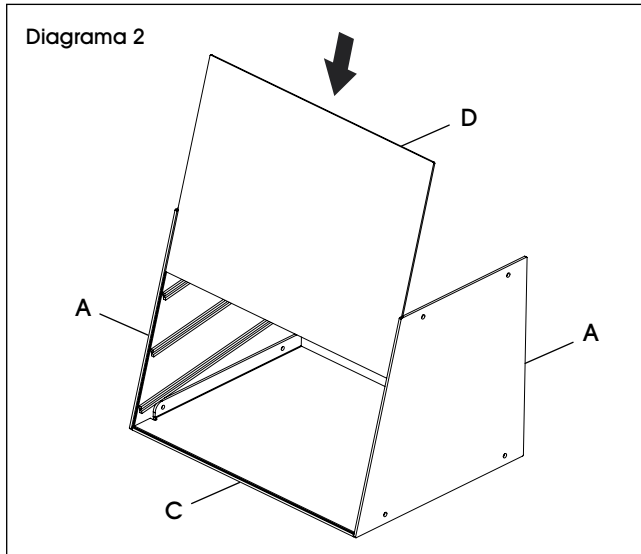

4. Ajuste las partes superior y posterior con bisagras (B) en la parte superior del exhibidor con la porción de la puerta con bisagras cubriendo la parte posterior. (Vea Diagrama 3)

 **NOTA:** Que una persona sostenga los paneles frontal y laterales, mientras que la otra persona coloca la parte superior y posterior con bisagras en el exhibidor.

 **NOTA:** Los imanes deben coincidir en la puerta con bisagras y la base (C).

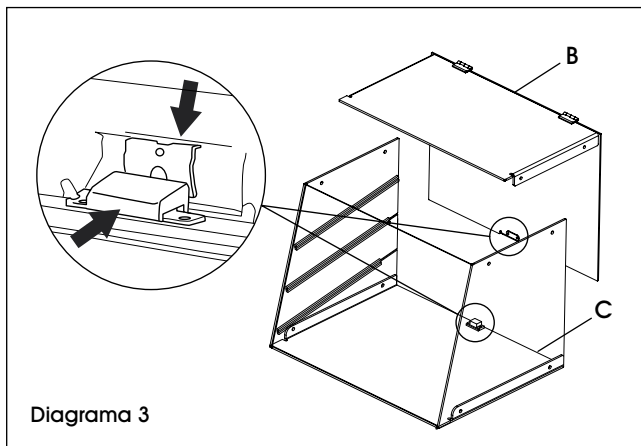

5. Alinee el canal de la parte superior y posterior con bisagras (B) con el frente (D) para asegurar el frente del exhibidor. El panel frontal (D) se debe ajustar de manera segura en los canales de todos los cuatro bordes. (Vea Diagrama 4)

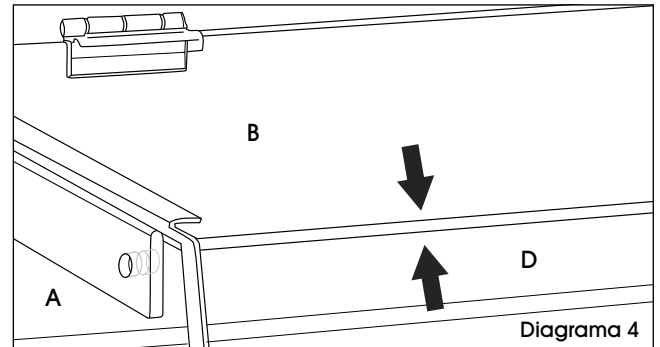

 **NOTA:** Los paneles laterales (A) deben estar en el exterior del panel superior (B). Asegure con los pernos (F) en el exterior y las tuercas (G) en el interior. (Vea Diagrama 5)

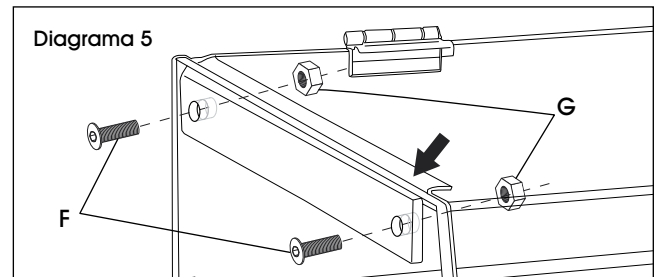

6. Abra la puerta con bisagras y deslice las tres charolas (E) hacia adentro. (Vea Diagrama 6)

 **NOTA:** Apriete ligeramente todos los tornillos para asegurar que todas las piezas queden ajustadas y el exhibidor quede estable. No los apriete demasiado.

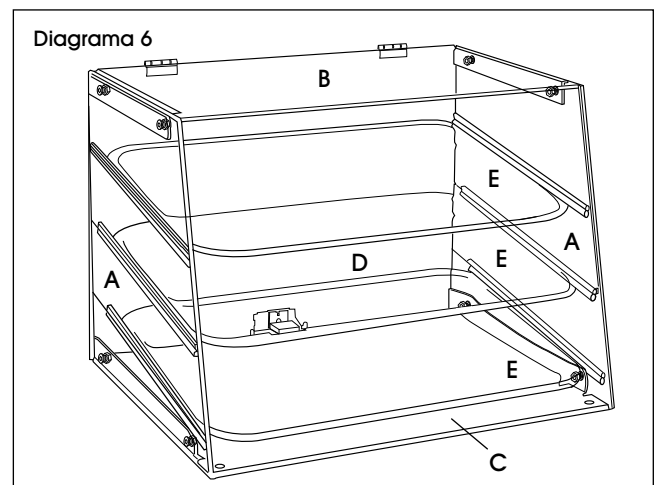

**ULINE**

800-295-5510  
uline.mx

# ULINE H-10825

## PRÉSENTOIR POUR BOULANGERIE

1 800 295-5510  
uline.ca

### OUTILS REQUIS



Clé Allen  
(inclus)



Mini clé  
(inclus)



Montage à deux  
personnes recommandé

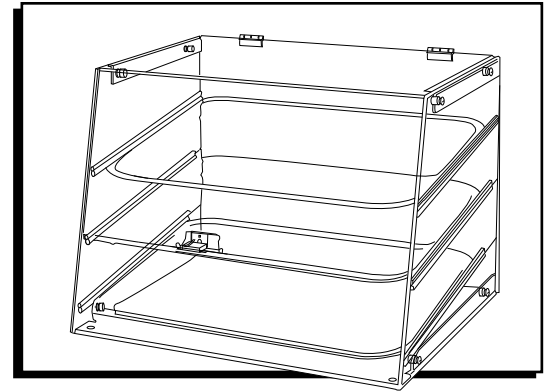

## PIÈCES

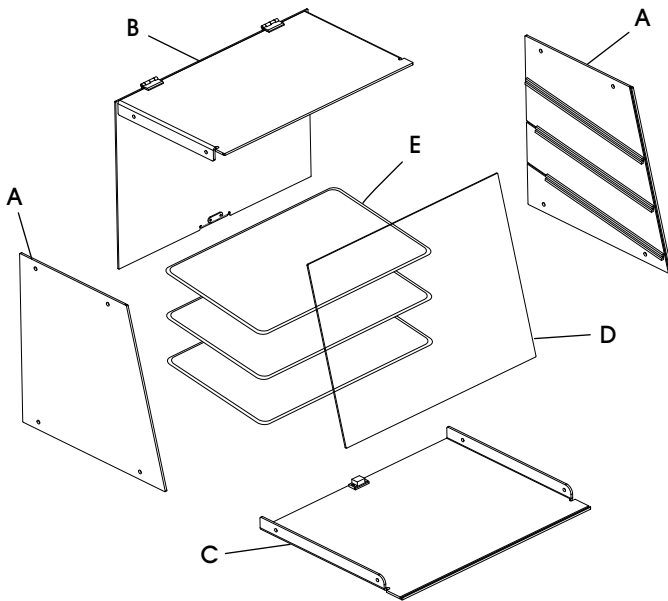

### PIÈCES

#	DESCRIPTION	QTÉ
A	Panneau latéral avec avant incliné	2
B	Panneaux supérieur et arrière à charnières	1
C	Base	1
D	Panneau avant	1
E	Plateau	3
F	Boulon	8
G	Écrou	8

### Matériel de fixation

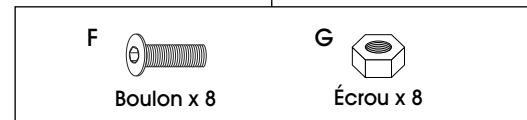

## MONTAGE



**REMARQUE :** Ne serrez pas trop les boulons. Une fois toutes les pièces assemblées, serrez légèrement tous les boulons pour vous assurer que les pièces sont bien ajustées et que le boîtier est stable.

1. Placez la base (C) avec les pieds en caoutchouc vers le bas, l'aimant étant orienté vers l'extérieur. (Voir Figure 1)
2. Fixez les panneaux latéraux (A) à la base en orientant le bord incliné vers l'avant, à l'opposé de l'aimant. (Voir Figure 1)



**REMARQUE :** La base (C) est munie d'un rebord sur les deux côtés. Fixez les panneaux latéraux (A) à l'extérieur du rebord à l'aide des écrous et des boulons.



**REMARQUE :** Les boulons doivent être à l'extérieur et orientés vers l'intérieur, et les écrous à l'intérieur.

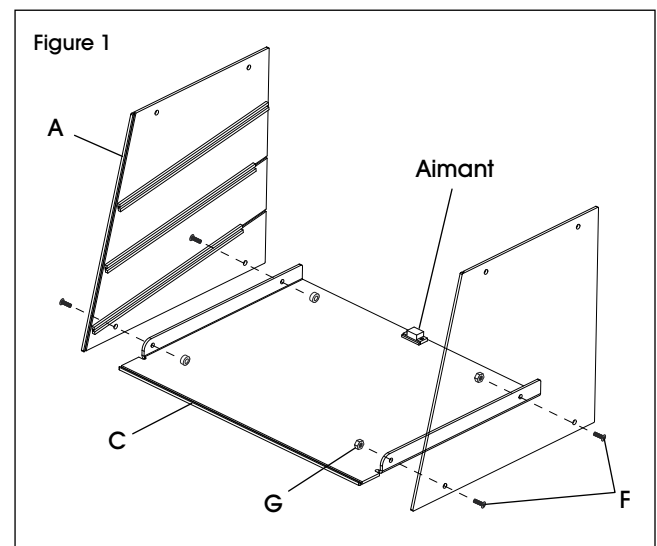

## MONTAGE SUITE

3. À deux, faites glisser le panneau avant (D) dans les rainures sur chaque panneau latéral (A) pour former l'avant du présentoir. (Voir Figure 2)

 **REMARQUE :** Le panneau avant (D) se glisse dans les rainures latérales jusqu'en bas, où il reposera dans une autre rainure de la base (C).

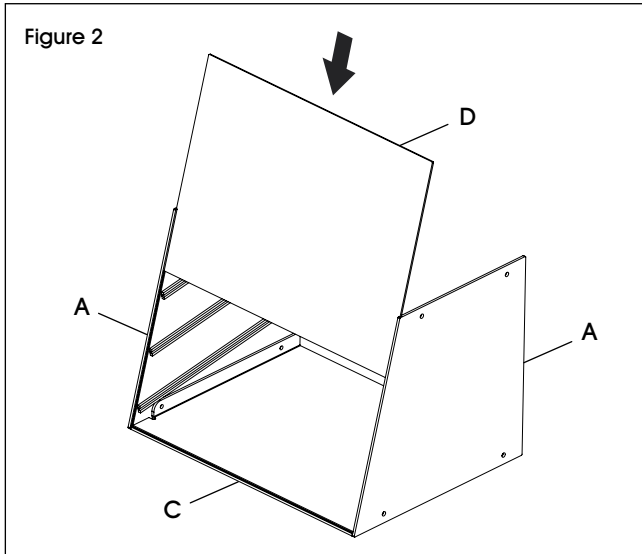

4. Placez les panneaux supérieur et arrière à charnières (B) sur le dessus du présentoir, la partie de la porte à charnières recouvrant l'arrière. (Voir Figure 3)

 **REMARQUE :** Une personne doit tenir les panneaux avant et latéraux pendant qu'une autre personne fixe les panneaux supérieur et arrière à charnières au présentoir.

 **REMARQUE :** Les aimants sur la porte à charnières et la base (C) doivent s'aligner.

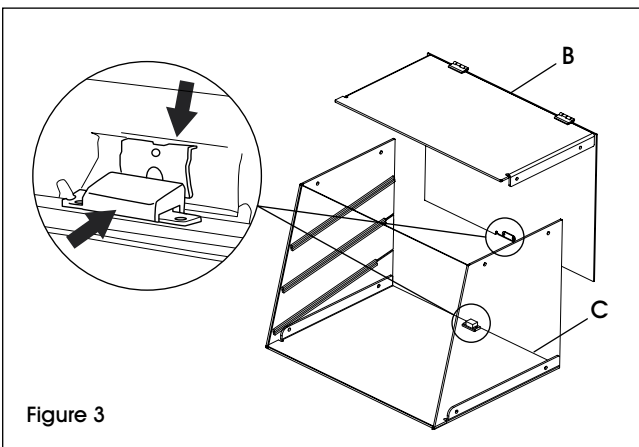

5. Alignez la rainure des panneaux supérieur et arrière à charnières (B) contre le panneau avant (D) pour fixer l'avant du présentoir. Le panneau avant (D) doit s'emboîter solidement dans les rainures figurant sur les quatre bords. (Voir Figure 4)

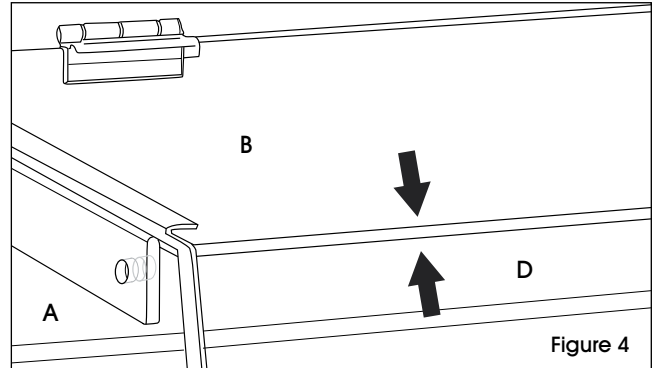

 **REMARQUE :** Les panneaux latéraux (A) doivent être à l'extérieur du panneau supérieur (B). Fixez avec les boulons (F) à partir du côté extérieur et les écrous (G) du côté intérieur. (Voir Figure 5)

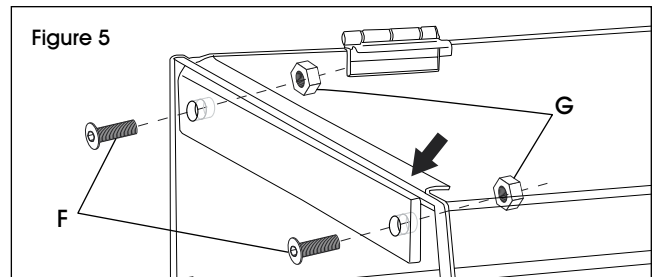

6. Ouvrez la porte à charnières et insérez les trois plateaux (E). (Voir Figure 6)

 **REMARQUE :** Serrez légèrement toutes les vis pour vous assurer que les pièces sont bien ajustées et que le boîtier est stable. Ne serrez pas trop.

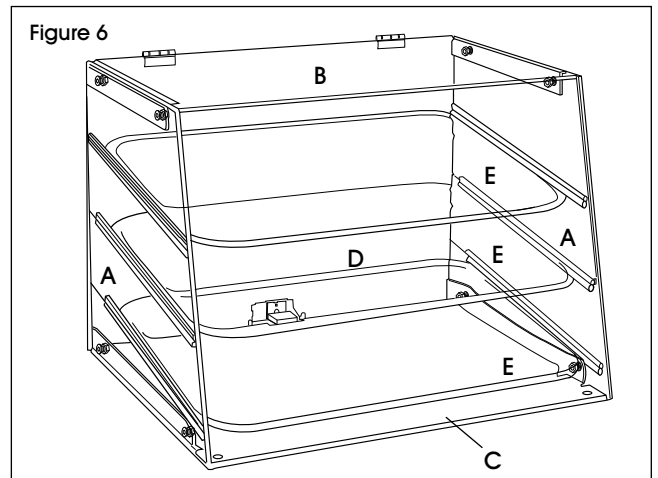

**ULINE**

1 800 295-5510  
uline.ca