

# ULINE H-10964 MESH WALL FILE

1-800-295-5510  
uline.com

## TOOLS NEEDED



Drill



Drill Bit

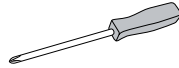

Phillips  
Screwdriver

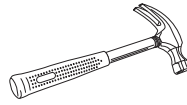

Hammer

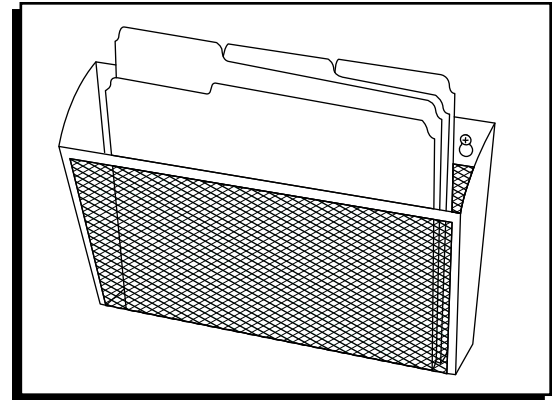

## INSTALLATION

1. Using the mesh wall file as a template, mark holes where screws will be located. (See Figure 1)

Figure 1

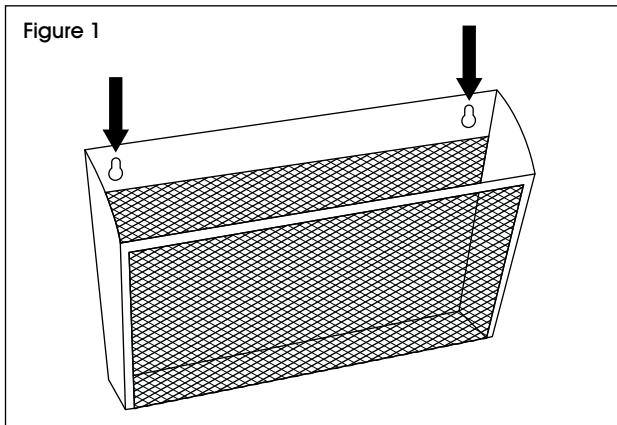

4. Secure wall file to wall with Phillips screwdriver and two screws. (See Figure 3)

Figure 3

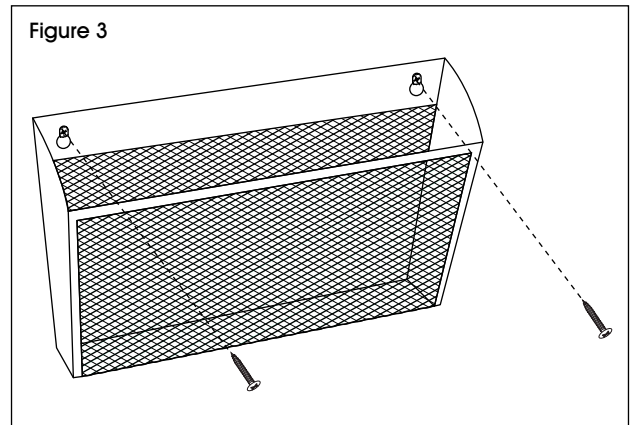

2. Drill holes into wall at previously marked locations.
3. Tap anchors into holes with hammer until flush with wall. (See Figure 2)

Figure 2

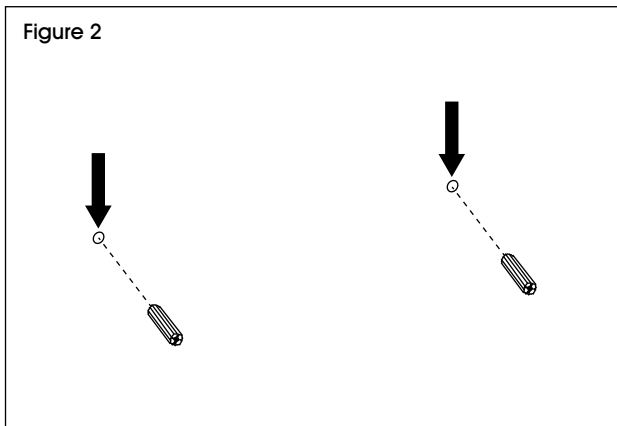

**ULINE** H-10964

800-295-5510

uline.mx

# CLASIFICADOR DE DOCUMENTOS DE MALLA PARA PARED

## HERRAMIENTAS NECESARIAS



Taladro



Broca

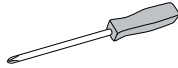

Desarmador de Cruz

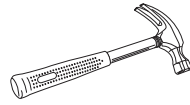

Martillo

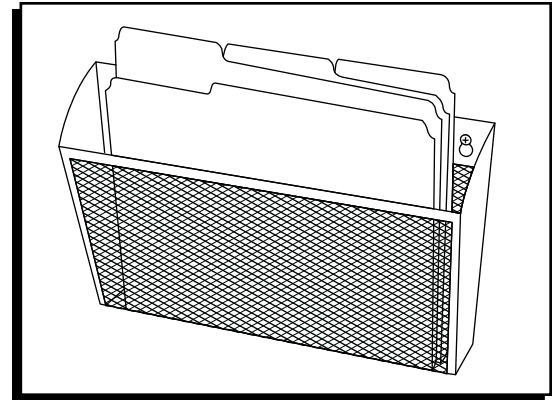

## INSTALACIÓN

1. Utilizando el clasificador de documentos de malla para pared como plantilla, marque los orificios en los que se colocarán los tornillos. (Vea Diagrama 1)

Diagrama 1

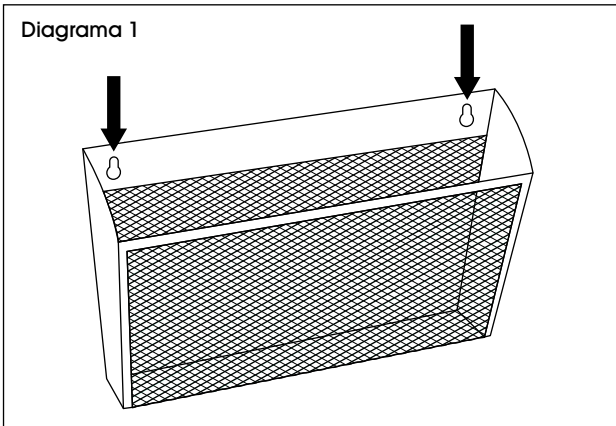

4. Asegure el clasificador de documentos con el desarmador de cruz y dos tornillos. (Vea Diagrama 3)

Diagrama 3

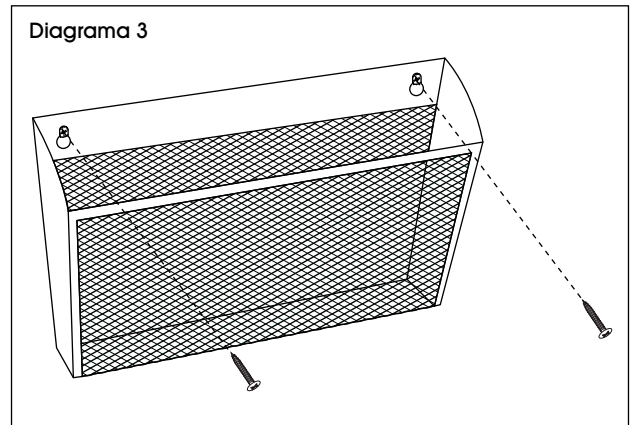

2. Perfore la pared en las ubicaciones previamente marcadas.
3. Golpee los taquetes dentro de los orificios con el martillo hasta que queden a ras de la pared. (Vea Diagrama 2)

Diagrama 2

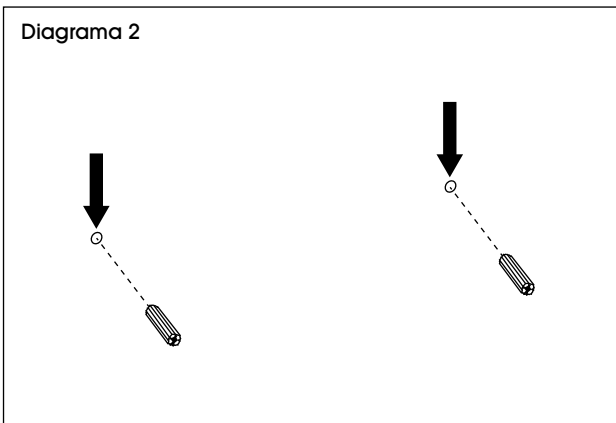

**ULINE** H-10964

# CLASSEUR MURAL GRILLAGÉ

1-800-295-5510

uline.ca

## OUTILS REQUIS



Perceuse



Mèche de perceuse

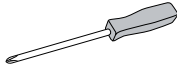

Tournevis  
cruiforme

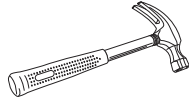

Marteau

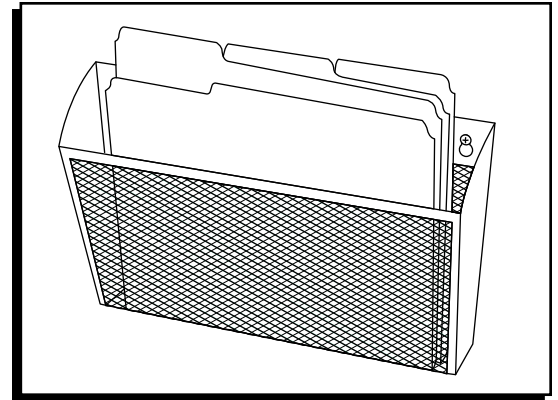

## INSTALLATION

1. En utilisant le classeur mural grillagé comme modèle, marquez les trous où les vis seront situées. (Voir Figure 1)
4. Fixez le classeur au mur à l'aide de deux vis et d'un tournevis cruciforme. (Voir Figure 3)

Figure 1

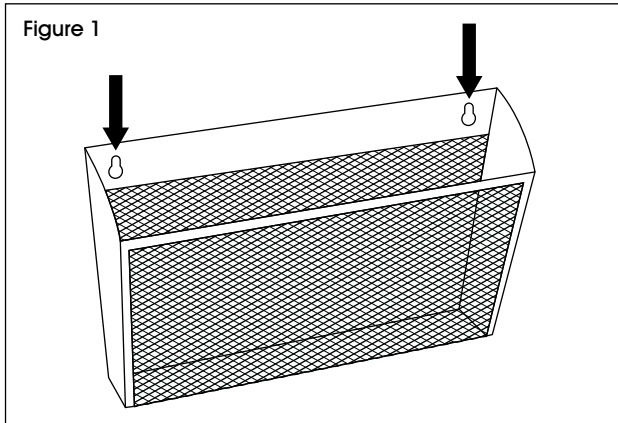
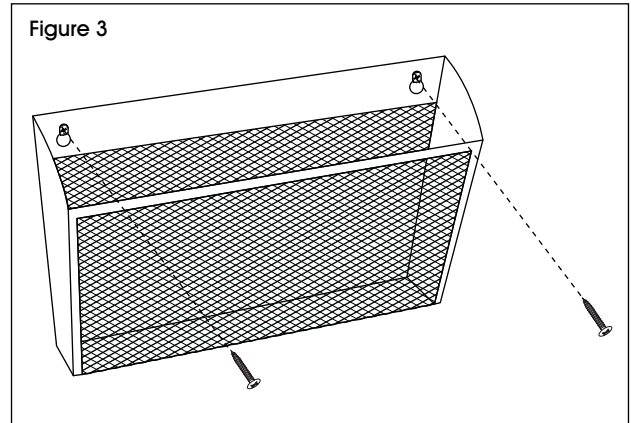

Figure 3



2. Percez des trous dans le mur aux endroits préalablement marqués.
3. Enfoncez des ancrages dans les trous au ras du mur en les tapotant avec le marteau. (Voir Figure 2)

Figure 2

