

# ULINE H-11092, H-11093 MOBILE ACTIVITY TABLE

1-800-295-5510  
uline.com

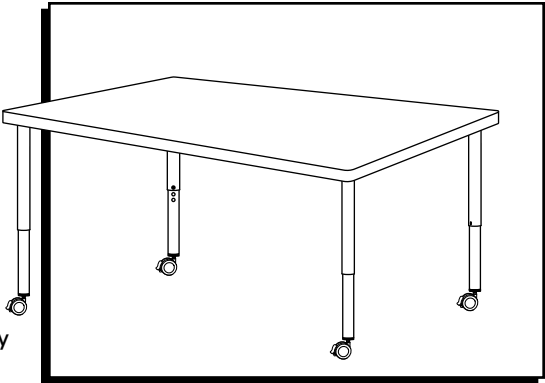

## TOOLS NEEDED

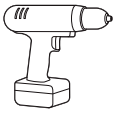

Drill



Phillips Head  
Drill Bit



Two Person Assembly  
Recommended

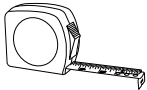

Tape Measure



Allen Wrench  
(included)



Wrench  
(included)



Rubber Mallet  
(optional)

## PARTS

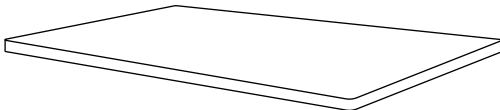

Tabletop x 1



Lower Leg x 4

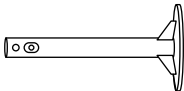

Upper Leg x 4



Caster x 4



#10 x 1" Screw x 16



Set Screw x 4

## ASSEMBLY



**NOTE: Count and inspect all pieces before disposing of any carton or packing materials.**

1. With a second person, place tabletop upside down on a smooth, non-marring surface to prevent scratching. Metal, L-shaped brackets should be facing up. (See Figure 1)

2. Slide upper leg plate under L-shaped bracket. Align pilot hole in tabletop with slotted hole in plate. Repeat for remaining upper legs. (See Figure 2)



**NOTE: If necessary, use a rubber mallet to fully slide upper leg plate into place.**

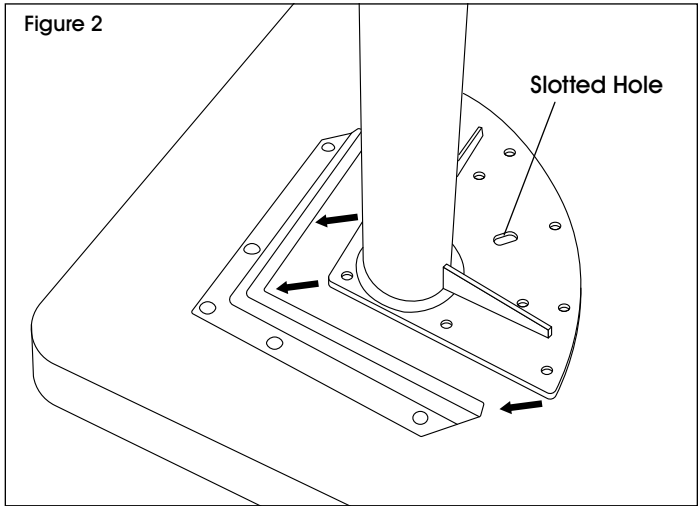
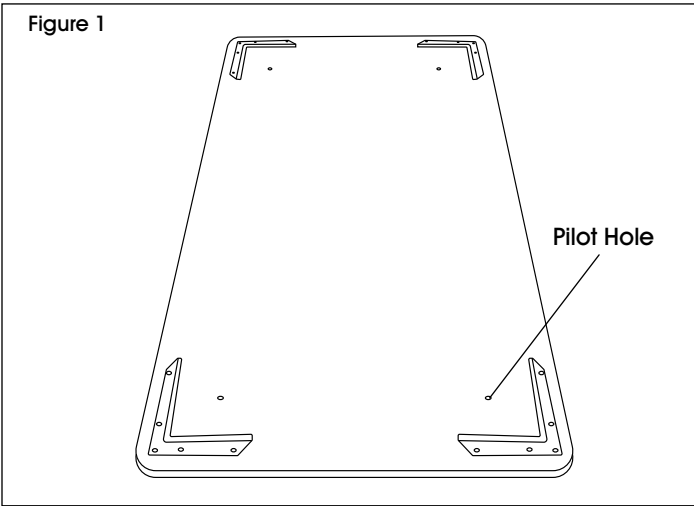

## ASSEMBLY CONTINUED

- Attach upper legs to tabletop using four #10 x 1" screws and drill. Repeat for remaining upper legs. (See Figure 3)

 **NOTE:** Only one pilot hole is pre-drilled. If preferred, additional pilot holes can be drilled for remaining bolts using a 1/8" drill bit.

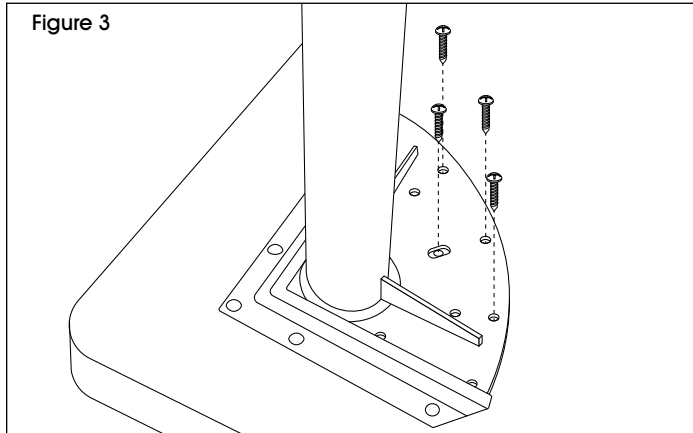

 **NOTE:** If stationary table is preferred, leave leveling glides installed and skip to step 5.

- Remove leveling glide from lower leg. Install caster into lower leg. Tighten using wrench. Repeat for remaining lower legs. (See Figure 4)

 **IMPORTANT!** Caster connection may loosen over time. Check casters and retighten with wrench every 3-4 months to ensure stability.

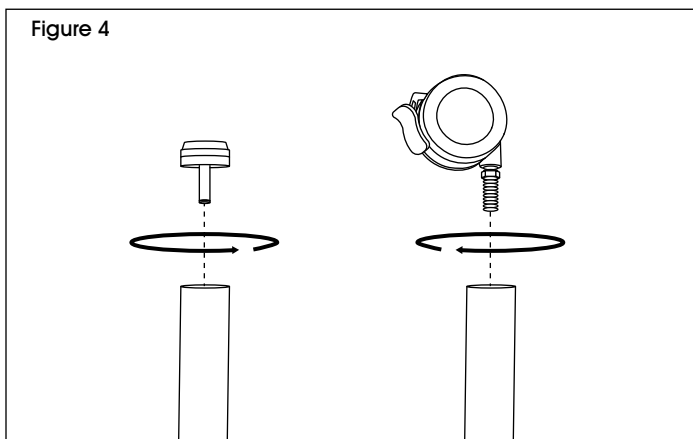

- Insert lower leg into upper leg tube. Measuring from the ground to the end of the caster, raise the lower leg to reach desired table height. Set table height by installing one set screw through upper leg, and into lower leg hole with Allen wrench. Repeat for remaining legs. (See Figure 5)

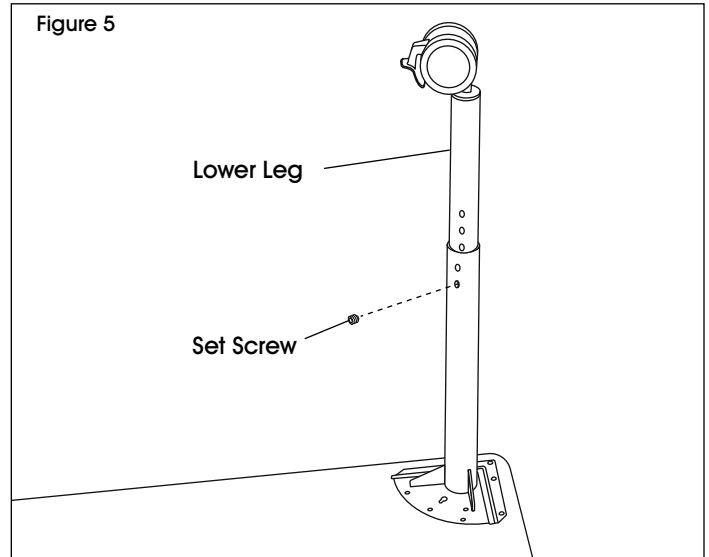

- With a second person, carefully flip table onto casters.

**ULINE**

1-800-295-5510  
uline.com

**ULINE** H-11092, H-11093

# MESA MÓVIL PARA CAPACITACIÓN

## HERRAMIENTAS NECESARIAS



Taladro



Broca de Cruz

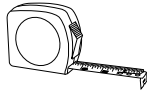

Cinta Métrica



Se Recomienda Armar  
Entre Dos Personas

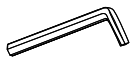
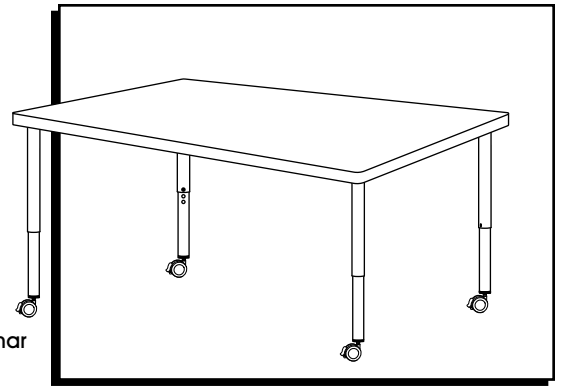

Llave Allen  
(incluida)



Llave  
(incluida)



Mazo de Caucho  
(Opcional)

## PARTES

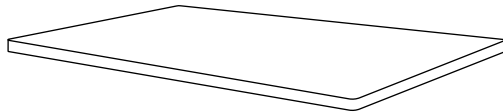

1 Cubierta

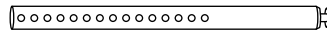

4 Patas Inferiores

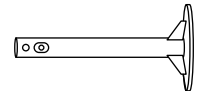

4 Patas Superiores



4 Ruedas



16 Tornillos #10 X 1"



4 Tornillos de Ajuste

## ENSAMBLE



**NOTA:** Cuente e inspeccione todas las piezas antes de desechar cualquier caja o material de empaque.

1. Con ayuda de otra persona, coloque la mesa boca abajo sobre una superficie lisa que no deje marcas para evitar rayones. Los soportes metálicos en L deben quedar boca arriba. (Vea Diagrama 1)

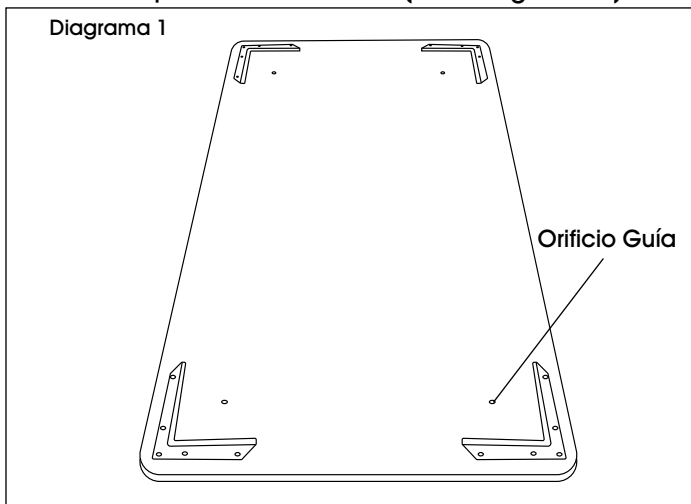

2. Deslice la pata superior debajo del soporte en L. Alinee el orificio guía de la cubierta con el orificio ranurado de la placa. Repita para las patas restantes. (Vea Diagrama 2)



**NOTA:** De ser necesario, utilice un mazo de caucho para deslizar por completo la placa de la pata superior.

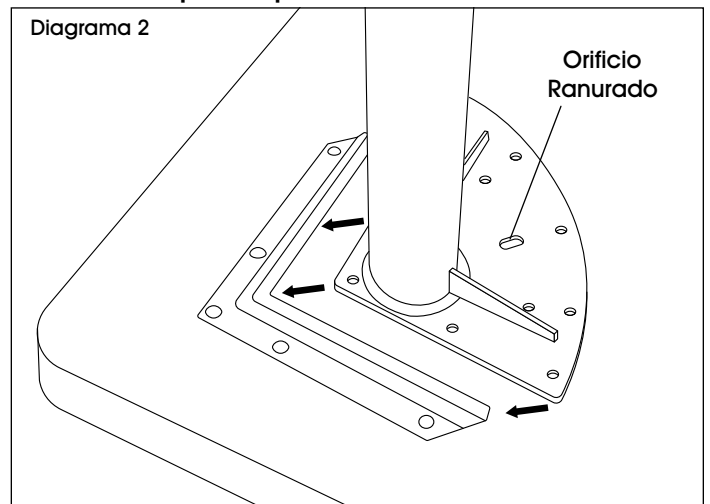

## CONTINUACIÓN DEL ENSAMBLE

3. File las patas superiores a la cubierta utilizando el taladro y cuatro tornillos #10 x 1". Repita para las patas superiores restantes. (Vea Diagrama 3)

 **NOTA:** Solo un orificio guía está preperforado. Si lo prefiere, puede perforar orificios adicionales para los pernos restantes utilizando una broca de 1/8".

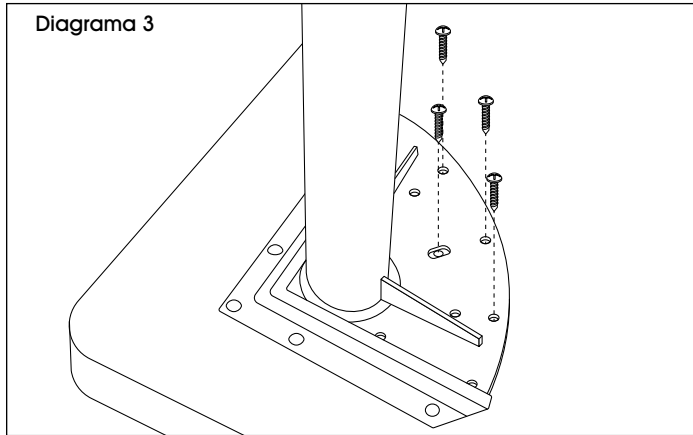

 **NOTA:** Si desea que la mesa sea fija, no retire las tapas niveladoras y vea el paso 5.

4. Retire la tapa niveladora de la pata inferior e instale la rueda. Apriete con la llave. Repita para las patas inferiores restantes. (Vea Diagrama 4)

 **¡IMPORTANTE!** Puede que las ruedas se aflojen con el tiempo. Revise y apriete las ruedas con una llave cada 3 ó 4 meses para mantener la estabilidad.

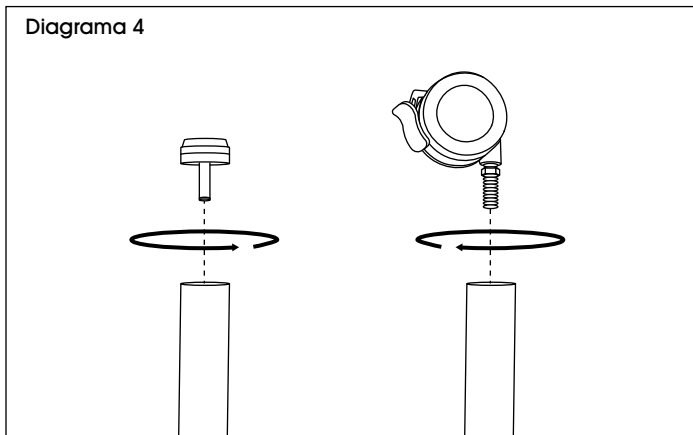

5. Instale la pata inferior en el tubo de la pata superior. Eleve la pata inferior hasta alcanzar la altura de mesa deseada, midiendo desde el suelo hasta el final de la rueda. Fije la altura de la mesa instalando un tornillo de ajuste en la pata superior y el orificio de la pata inferior con la llave Allen. Repita la operación con las patas restantes. (Vea Diagrama 5)

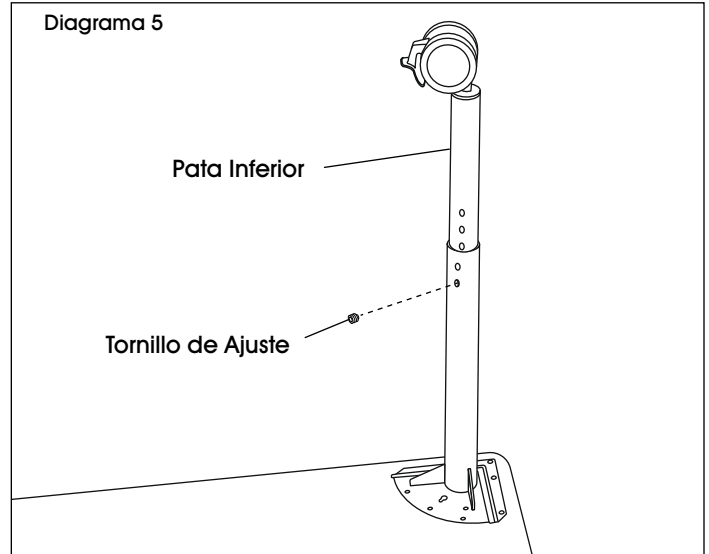

6. Con ayuda de otra persona, voltee con cuidado la mesa y póngala de pie.

**ULINE**

800-295-5510  
uline.mx

**ULINE** H-11092, H-11093

1-800-295-5510  
uline.ca

# TABLE MOBILE POUR ACTIVITÉS

## OUTILS REQUIS



Perceuse



Mèche de perceuse  
cruciforme



Montage à deux  
personnes recommandé

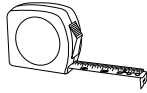

Ruban à  
mesurer



Clé Allen  
(inclus)



Clé  
(inclus)



Maillet en caoutchouc  
(optionnel)

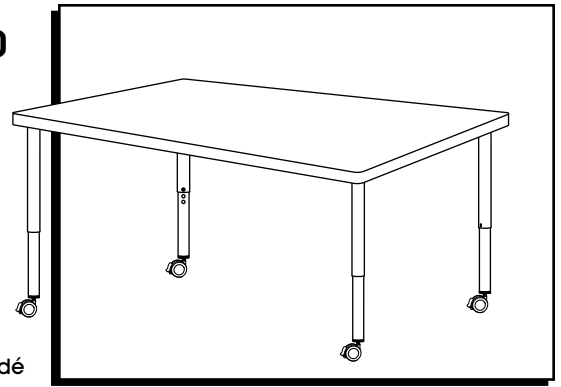

## PIÈCES

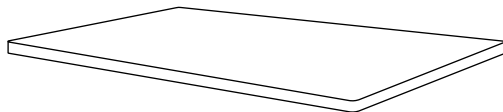

Surface de table x 1



Pied inférieur x 4

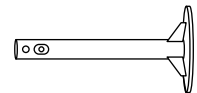

Pied supérieur x 4



Roulette x 4



Vis n° 10 x 1 po x 16



Vis de réglage x 4

## MONTAGE



**REMARQUE :** Comptez et inspectez toutes les pièces avant de jeter le matériel d'emballage ou le carton.

1. À deux, placez la surface de table à l'envers sur une surface lisse qui ne marque pas pour éviter les rayures. Les supports métalliques en L doivent être orientés vers le haut. (Voir Figure 1)

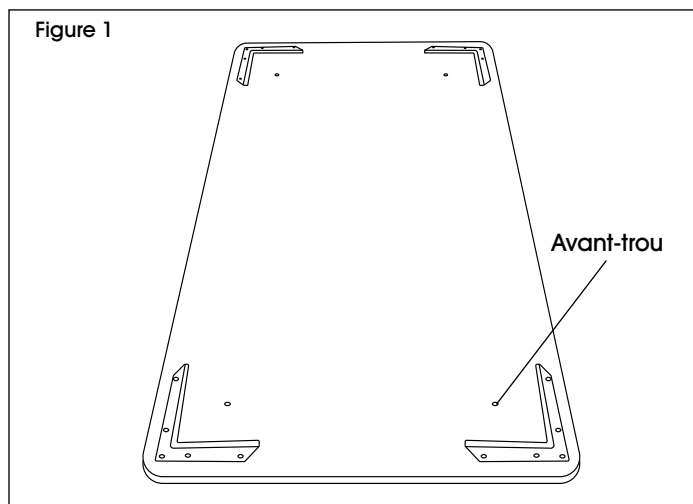

2. Faites glisser la plaque de pied supérieur sous le support en L. Alignez l'avant-trou de la surface de table sur le trou oblong de la plaque. Répétez l'opération pour les autres pieds supérieurs. (Voir Figure 2)



**REMARQUE :** Si nécessaire, utilisez un maillet en caoutchouc pour faire glisser complètement la plaque de pied supérieur en place.

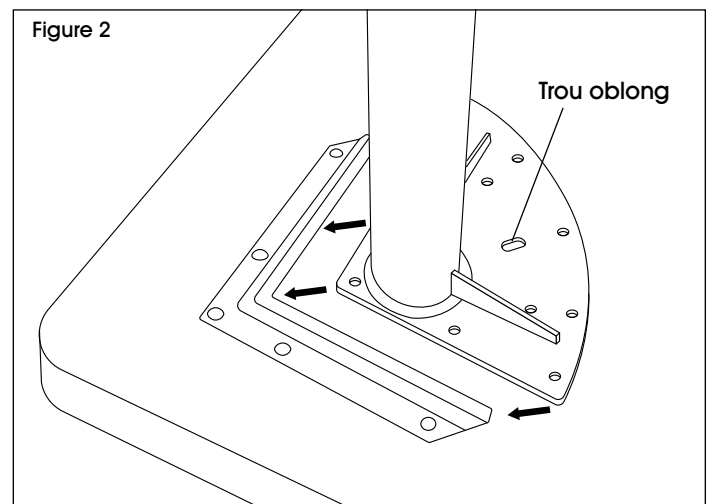

## MONTAGE SUITE

- Fixez les pieds supérieurs à la surface de table à l'aide de quatre vis n° 10 x 1 po et d'une perceuse. Répétez cette étape pour les autres pieds supérieurs. (Voir Figure 3)

 **REMARQUE :** Un seul avant-trou est prépercé. Au besoin, des avant-trous supplémentaires peuvent être percés pour les boulons restants à l'aide d'une mèche de 1/8 po.

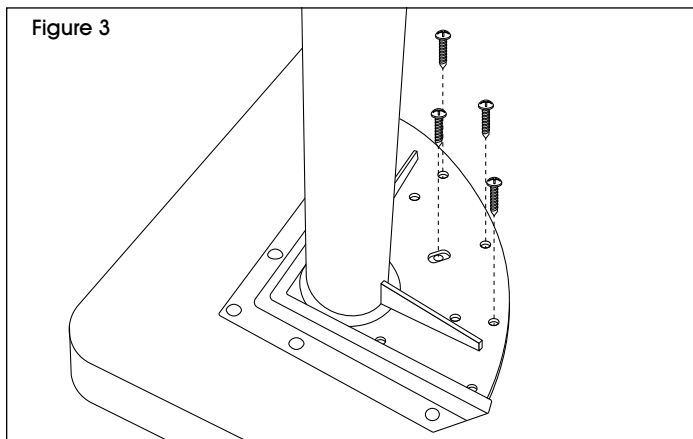

 **REMARQUE :** Si vous préférez une table fixe, laissez les patins de nivellement en place et passez à l'étape 5.

- Retirez le patin de nivellement du pied inférieur. Insérez une roulette dans le pied inférieur. Serrez le tout avec la clé. Répétez ces étapes pour les autres pieds inférieurs. (Voir Figure 4)

 **IMPORTANT!** Le raccord des roulettes peut se desserrer avec le temps. Vérifiez les roulettes et resserrez-les à l'aide d'une clé tous les 3 à 4 mois pour garantir la stabilité.

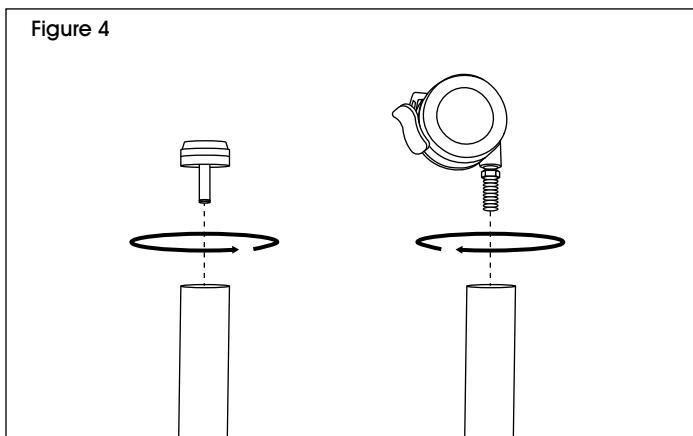

- Insérez le pied inférieur dans le tube du pied supérieur. En mesurant à partir du sol jusqu'à l'extrémité de la roulette, soulevez le pied inférieur pour obtenir la hauteur de table souhaitée. Réglez la hauteur de la table en installant une vis de réglage à travers le pied supérieur, puis dans le trou du pied inférieur à l'aide d'une clé Allen. Répétez ces étapes pour les autres pieds. (Voir Figure 5)

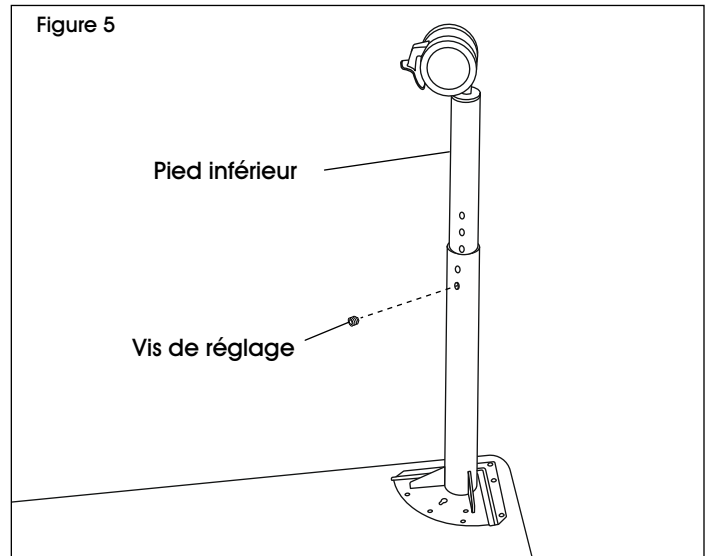

- À deux, faites basculer avec précaution la table sur les roulettes.

**ULINE**

1-800-295-5510  
uline.ca