

ULINE H-11148, H-11149
H-12027, H-12028
INDUSTRIAL COLLECTION
OFFICE STORAGE

1-800-295-5510
uline.com

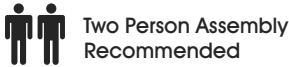
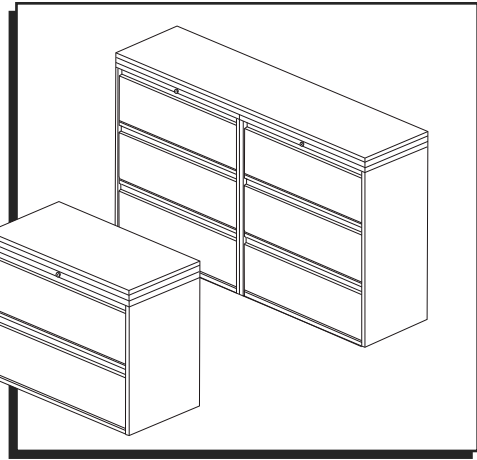

Two Person Assembly
Recommended

ASSEMBLY

LATERAL FILE CABINET ASSEMBLY

1. Place file cabinet in desired location.
2. Place top panel upside down on a smooth surface with metal frame facing up. Remove liner from adhesive on the metal frame. (See Figure 1)

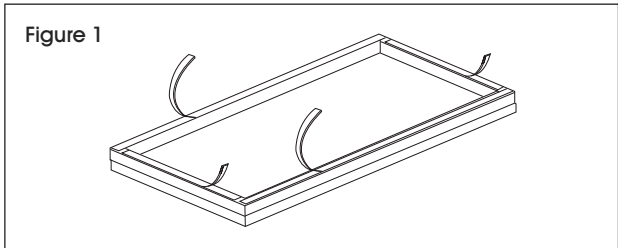

3. Carefully place top panel onto the file cabinet to ensure proper alignment. Press down firmly on the top panel to secure it in place. (See Figures 2-3)

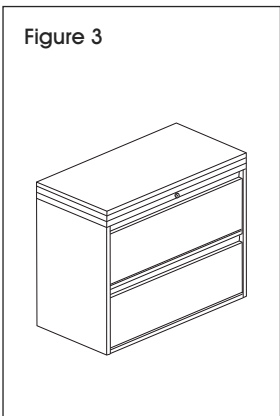
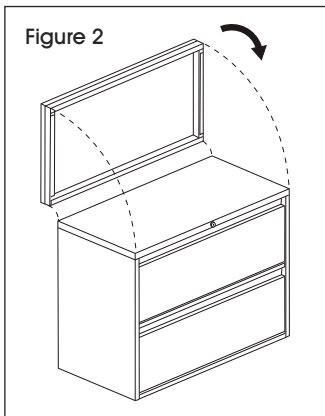

CREDENZA ASSEMBLY

1. Place file cabinets next to each other in desired location. (See Figure 4)

 **NOTE:** To ensure proper alignment of top panel, file cabinets should not have any space between them, and leveling feet should be adjusted to ensure both file cabinets are set to the same height.

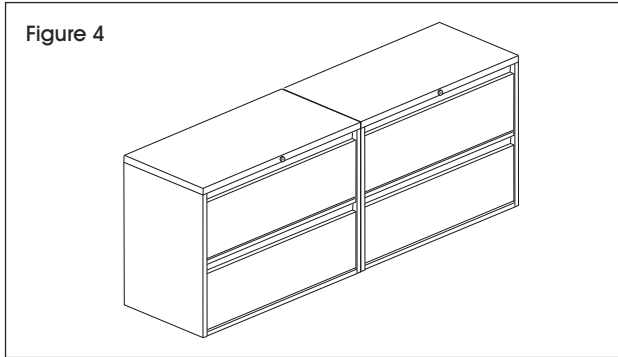

2. Place top panel upside down on a smooth surface with metal frame facing up. Remove liner from adhesive on the metal frame. (See Figure 5)

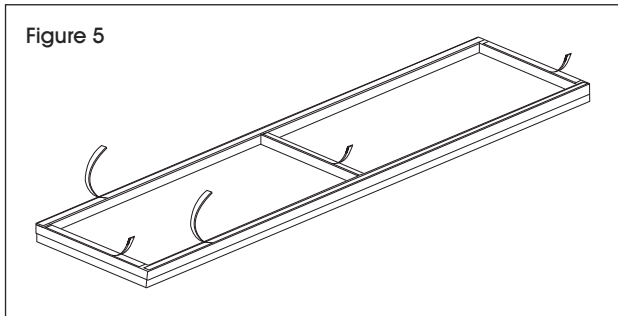

ASSEMBLY CONTINUED

- Carefully place top panel onto the file cabinets to ensure proper alignment. Press down firmly on the top panel to secure it in place. (See Figures 6-7)



NOTE: If credenza needs to be relocated, move carefully to ensure adhesive remains connected to the file cabinets.

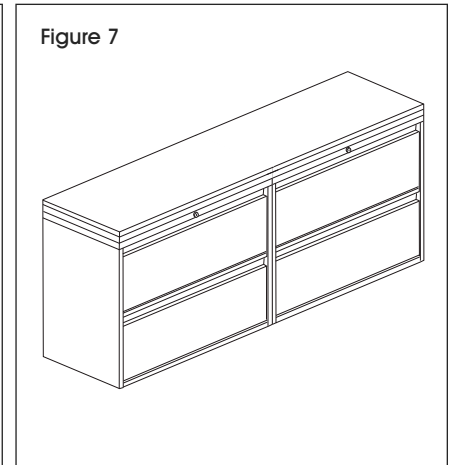
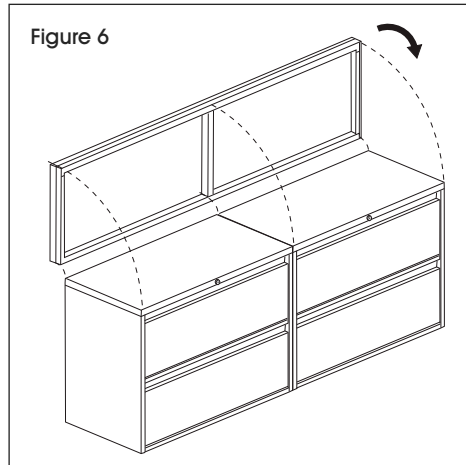

ULINE

1-800-295-5510
uline.com

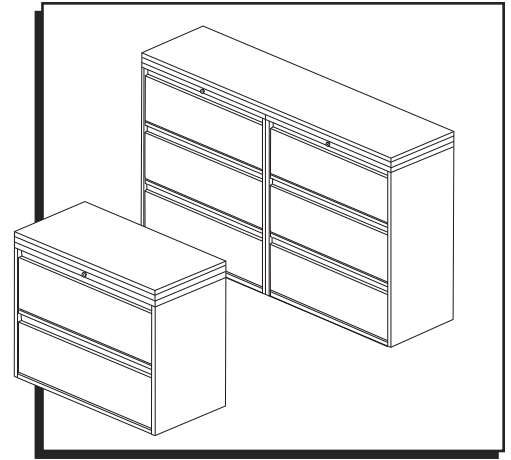

ENSAMBLE

ENSAMBLE DEL ARCHIVERO LATERAL

1. Coloque el archivero en la ubicación deseada.
2. En una superficie nivelada, voltee el panel superior lateral con el armazón de metal hacia arriba. Retire el respaldo del adhesivo del armazón de metal. (Vea Diagrama 1)

Diagrama 1

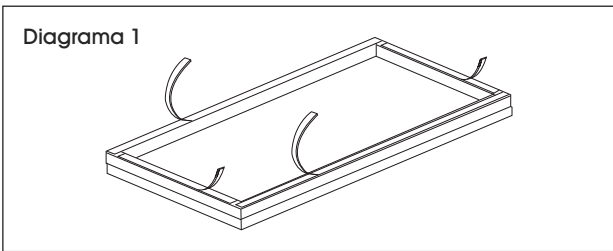

3. Coloque el panel superior con cuidado sobre el archivero para asegurarse de que estén bien alineados. Presione de manera firme sobre el panel superior para asegurarlo en su lugar. (Vea Diagramas 2-3)

Diagrama 2



Diagrama 3



ENSAMBLE DE LA CREDENZA

1. Coloque los archiveros uno al lado del otro en la ubicación deseada. (Vea Diagrama 4)

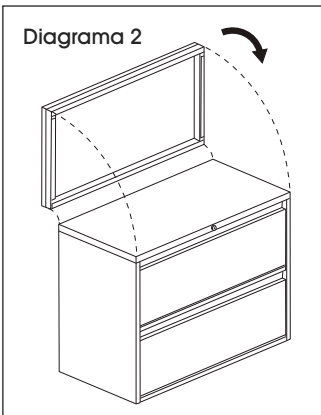
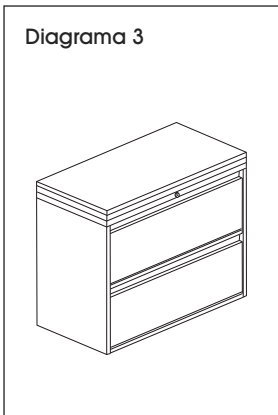

NOTA: Para asegurar que el panel superior esté bien alineado, no debe haber espacio entre los archiveros; las patas niveladoras deben ajustarse para garantizar que ambos archiveros estén a la misma altura.

Diagrama 4

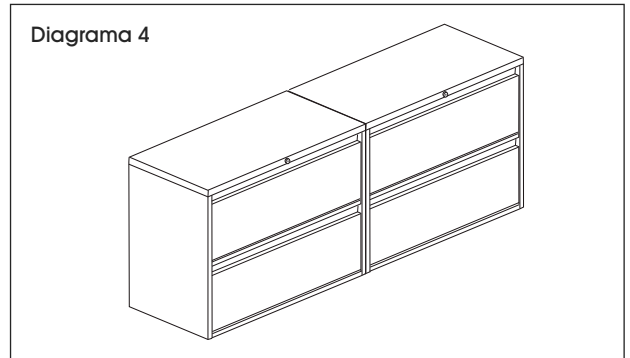

2. En una superficie nivelada, voltee el panel superior lateral con el armazón de metal hacia arriba. Retire el respaldo del adhesivo del armazón de metal. (Vea Diagrama 5)

Diagrama 5

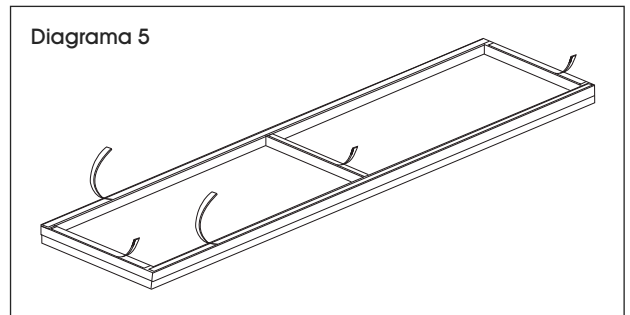

CONTINUACIÓN DEL ENSAMBLE

3. Coloque el panel superior con cuidado sobre los archiveros para asegurarse de que estén bien alineados. Presione de manera firme sobre el panel superior para asegurarlo en su lugar. (Vea Diagramas 6-7)



NOTA: Si necesita reubicar la credenza, muévala con cuidado para asegurarse de que el adhesivo permanezca conectado a los archiveros.

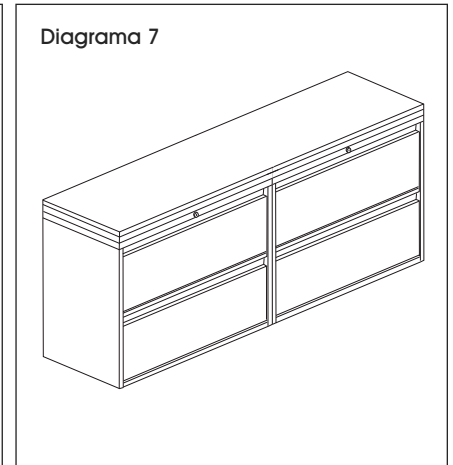
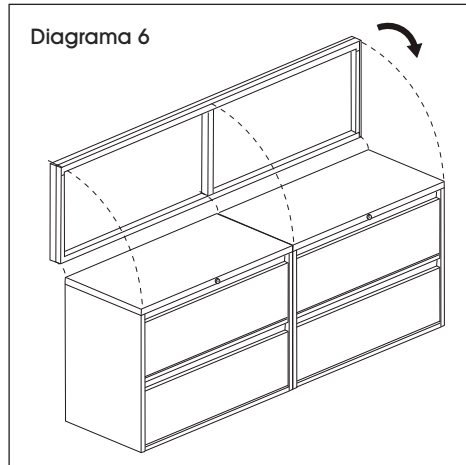

ULINE

800-295-5510
uline.mx

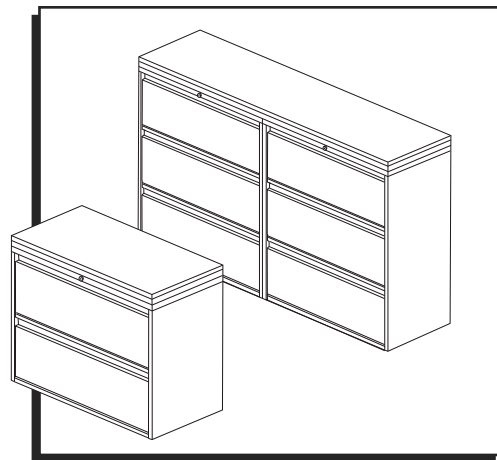
Montage à deux personnes
recommandé

MONTAGE

MONTAGE DU CLASSEUR LATÉRAL

1. Placez le classeur à l'emplacement souhaité.
2. Placez le panneau supérieur à l'envers sur une surface plane, le cadre en métal tourné vers le haut. Retirez la doublure de l'adhésif sur le cadre en métal. (Voir Figure 1)

Figure 1

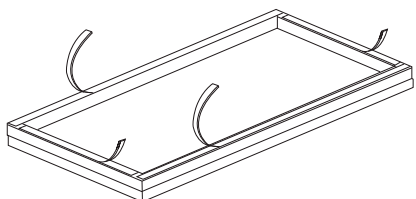

3. Placez avec précaution le panneau supérieur sur le classeur afin qu'il soit bien aligné. Appuyez fermement sur le panneau supérieur pour le fixer en place. (Voir Figures 2 et 3)

Figure 2

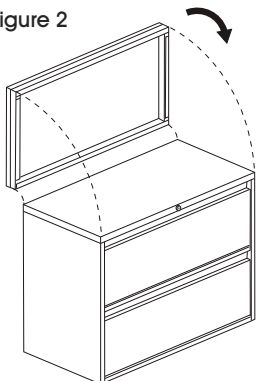
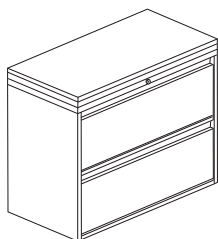

Figure 3



MONTAGE DU BAHUT

1. Placez les classeurs les uns à côté des autres à l'emplacement souhaité. (Voir Figure 4)



REMARQUE : Pour assurer un bon alignement du panneau supérieur, les classeurs ne doivent pas avoir d'espace entre eux et les pattes de nivellement doivent être ajustées pour que les deux classeurs soient à la même hauteur.

Figure 4

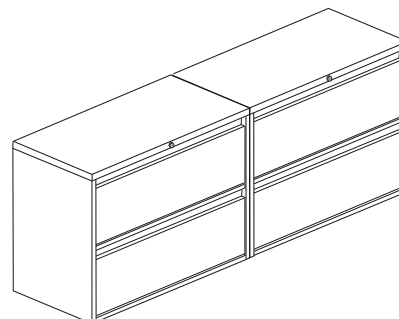

2. Placez le panneau supérieur à l'envers sur une surface plane, le cadre en métal tourné vers le haut. Retirez la doublure de l'adhésif sur le cadre en métal. (Voir Figure 5)

Figure 5

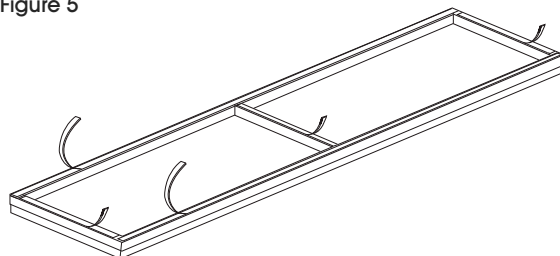

MONTAGE SUITE

- Placez avec précaution le panneau supérieur sur les classeurs afin qu'il soit bien aligné. Appuyez fermement sur le panneau supérieur pour le fixer en place. (Voir Figures 6 et 7)



REMARQUE : Si le bahut doit être déplacé, déplacez-le avec soin pour vous assurer que l'adhésif reste fixé aux classeurs.

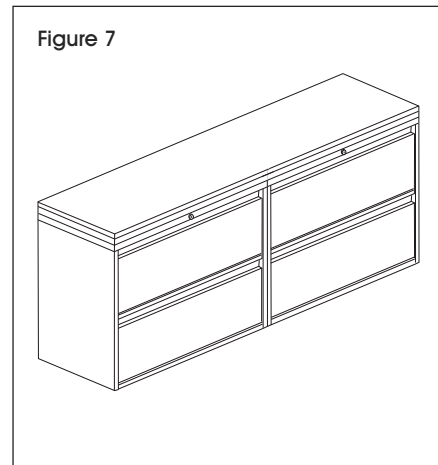
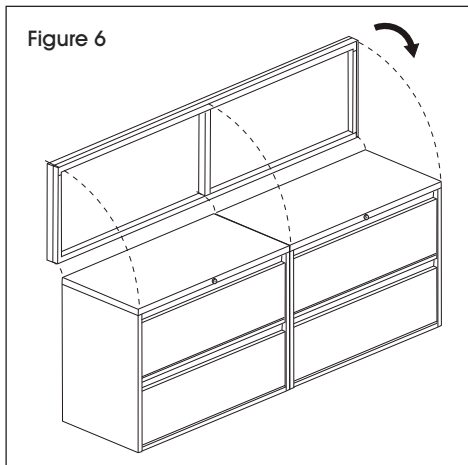

ULINE

1 800 295-5510
uline.ca