

# ULINE H-11351 SPILL CART

1-800-295-5510  
uline.com

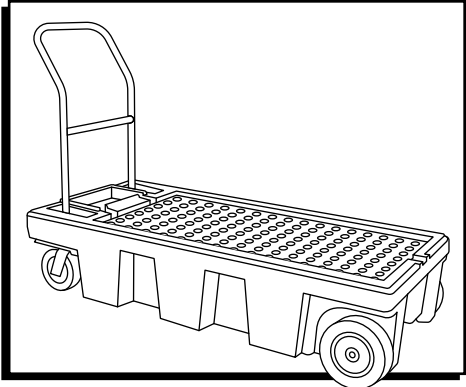

## TOOLS NEEDED



1/2" Wrench

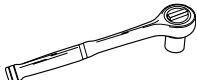

1/2" Socket  
Wrench

## PARTS

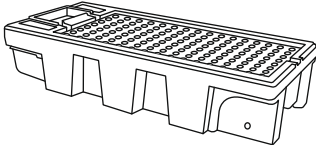

Deck x 1

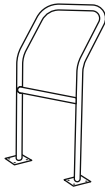

Handle x 1

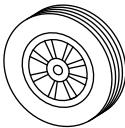

Wheel x 2



Swivel Caster x 2



Washer x 6

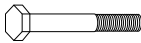

5 1/2" Bolt x 8



Flange Nut x 8



Cotter Pin x 2



Axle x 1

## ASSEMBLY

 **NOTE:** Parts are located inside deck for shipping.

### WHEEL ASSEMBLY

1. Slide two washers, wheel and outer washer onto axle.  
(See Figure 1)

 **NOTE:** Ensure hub on wheel is toward cart.

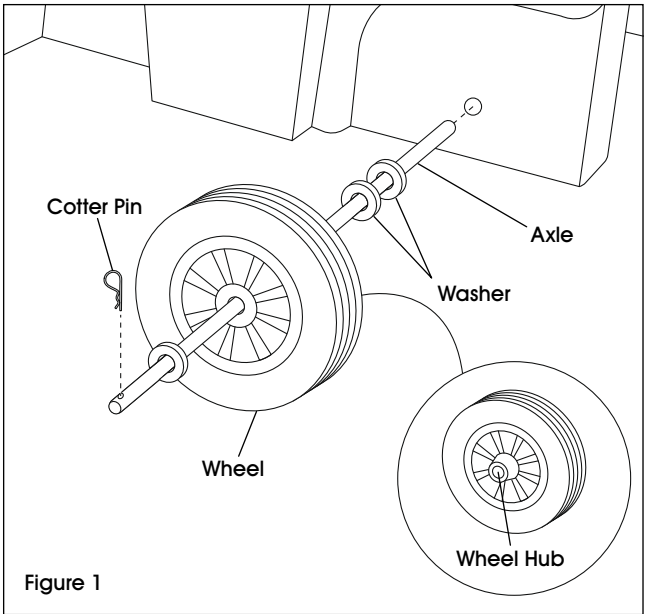

## ASSEMBLY CONTINUED

2. Insert cotter pin into end of the axle. Bend end of cotter pin to secure. (See Figure 2)

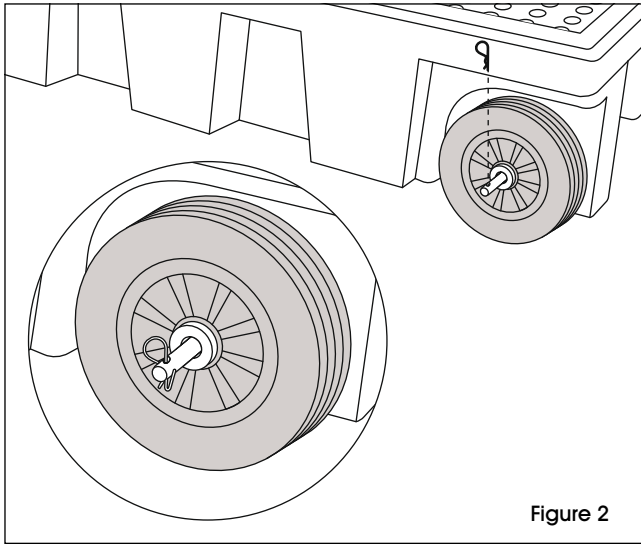

3. Repeat steps 1-2 for opposite side.

### HANDLE/CASTER ASSEMBLY

4. Place handle into holes until flanges are seated against deck. (See Figure 3)

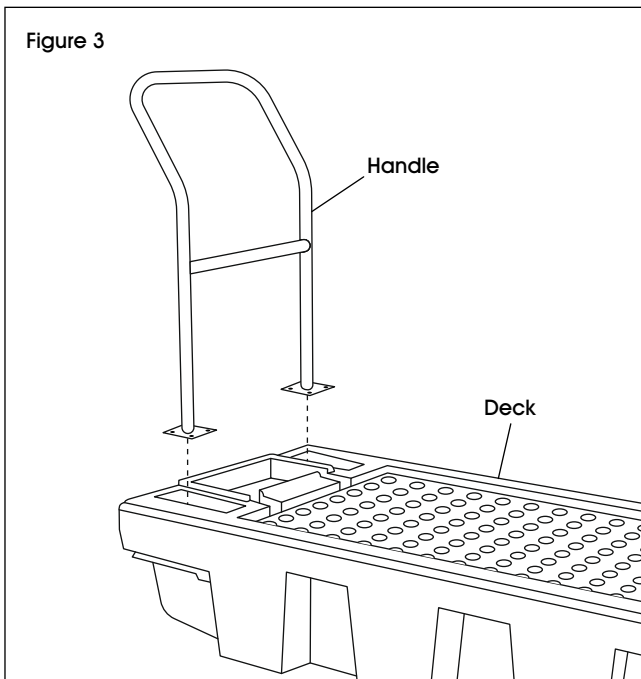

5. Insert bolts through the handle flange and deck. (See Figure 4)
6. Align casters with bolts protruding from bottom of deck. (See Figure 4)
7. Loosely thread a flange nut onto each bolt. Do not tighten. (See Figure 4)

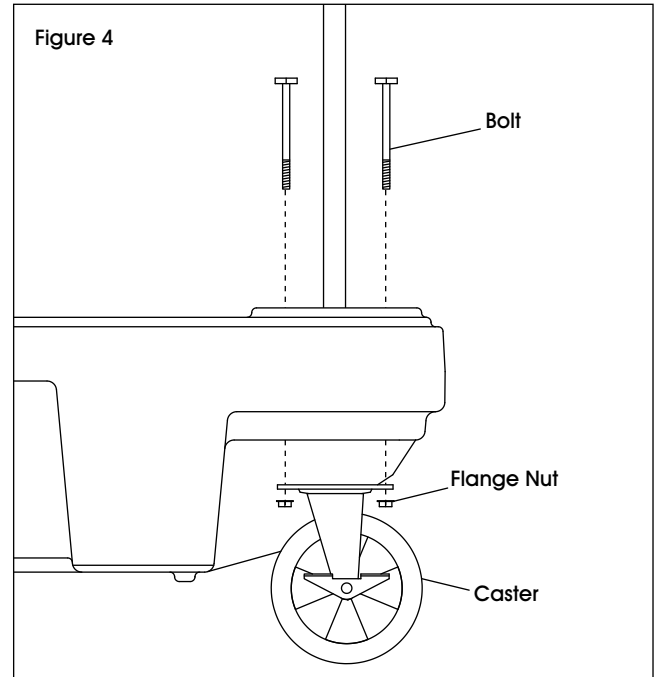

8. Repeat steps 5-7 for remaining caster and opposite side of handle.
9. Use 1/2" wrenches to tighten the casters to the handle.

**ULINE**

1-800-295-5510

uline.com

**ULINE H-11351**

# CARRITO PARA DERRAMES

800-295-5510

uline.mx

## HERRAMIENTAS NECESARIAS



Llave de 1/2"

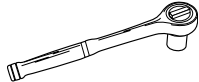

Llave de Dados de 1/2"

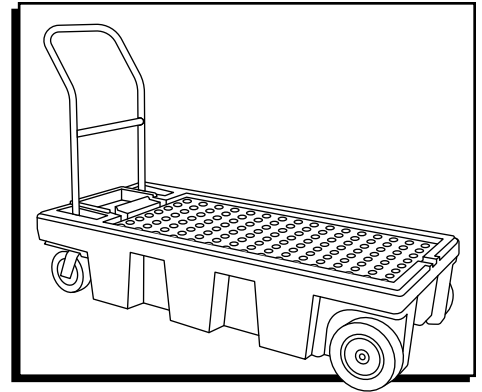

## PARTES

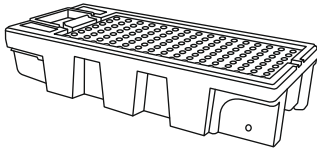

1 Plataforma

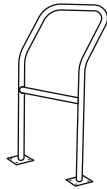

1 Asa

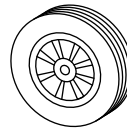

2 Llantas



2 Ruedas Giratorias



6 Rondanas

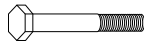

8 Pernos de 5 1/2"



8 Tuercas con Reborde

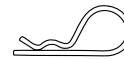

2 Pasadores de Chaveta



1 Eje

## ENSAMBLE



**NOTA:** Cuando se envía, las partes están localizadas dentro de la plataforma.

### ENSAMBLE DE LA LLANTA

1. Deslice dos rondanas, llanta y rondana exterior en el eje. (Vea Diagrama 1)



**NOTA:** Asegúrese de que el cubo de la llanta apunte hacia el carrito.

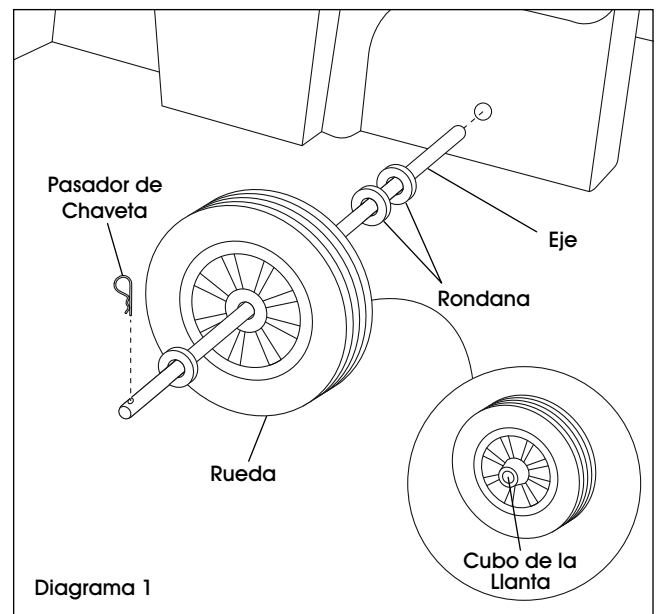

## CONTINUACIÓN DEL ENSAMBLE

2. Inserte el pasador de chaveta en un extremo del eje. Doble el extremo del pasador de chaveta para asegurarlo. (Vea Diagrama 2)

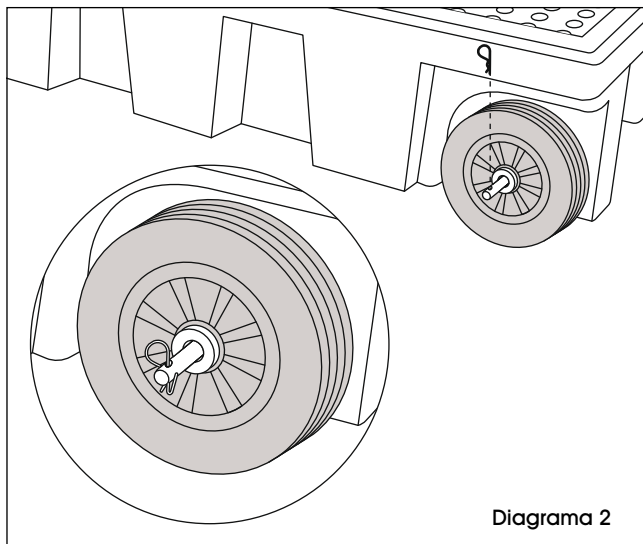

3. Repita los pasos 1-2 en el otro lado.

### ENSAMBLE DEL ASA/RUEDA

4. Coloque el asa en los orificios hasta que los rebordes se asienten contra la plataforma. (Vea Diagrama 3)

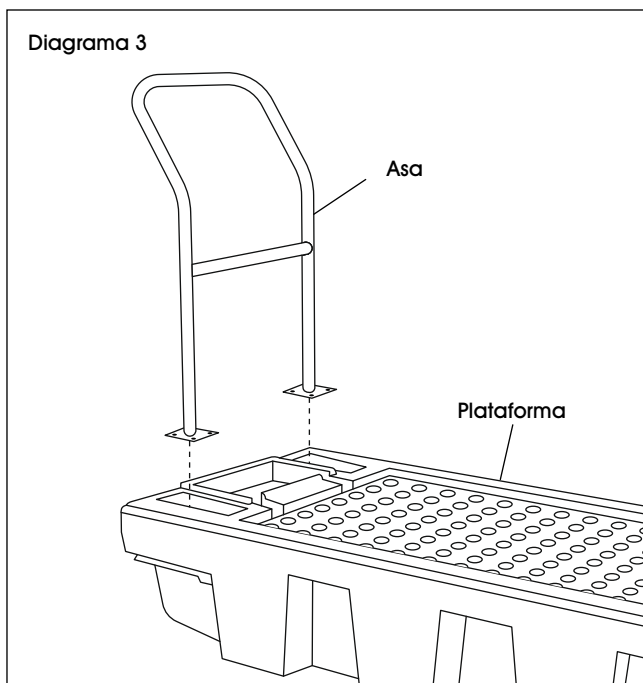

5. Inserte los pernos a través del reborde del asa y la plataforma. (Vea Diagrama 4)
6. Alinee las ruedas con los pernos que sobresalen de la parte inferior de la plataforma. (Vea Diagrama 4)
7. Pase una tuerca con reborde por cada perno. No los apriete. (Vea Diagrama 4)

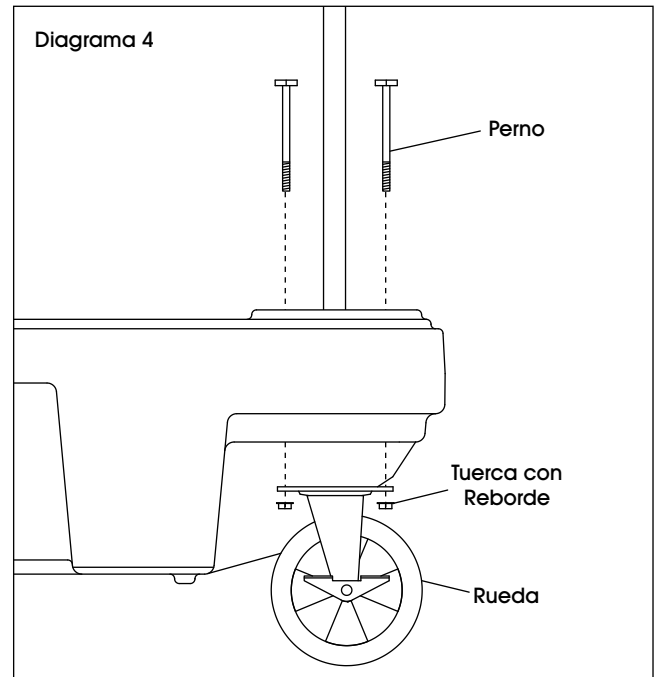

8. Repita los pasos 5-7 en la rueda restante y el otro lado del asa.
9. Utilice llaves de 1/2" para apretar las ruedas en el asa.

**ULINE**

800-295-5510  
uline.mx

**ULINE H-11351**

1-800-295-5510

uline.ca

# CHARIOT DE DÉVERSEMENT

## OUTILS REQUIS



Clé de 1/2 po

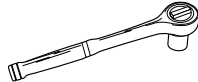

Clé à douille de 1/2 po

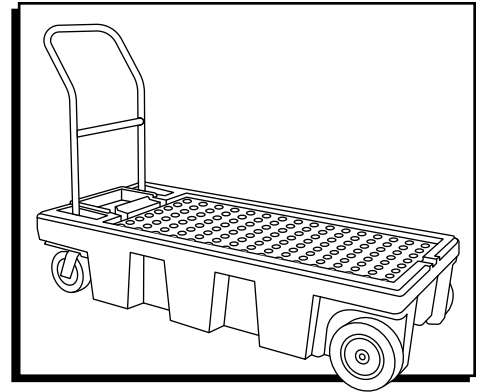

## PIÈCES

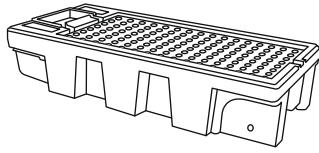

Plateforme x 1

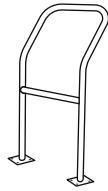

Poignée x 1

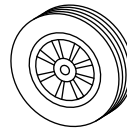

Roue x 2



Roulette pivotante x 2



Rondelle x 6

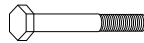

Boulon de 5 1/2 po x 8



Écrou à embase x 8

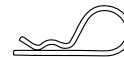

Goupille fendue x 2



Essieu x 1

## MONTAGE



**REMARQUE :** Les pièces sont placées à l'intérieur de la plateforme pour l'expédition.

### ENSEMBLE DE LA ROUE

1. Faites passer deux rondelles, la roue, puis la rondelle extérieure sur l'essieu. (Voir Figure 1)



**REMARQUE :** Assurez-vous que le moyeu de la roue est orienté vers le chariot.

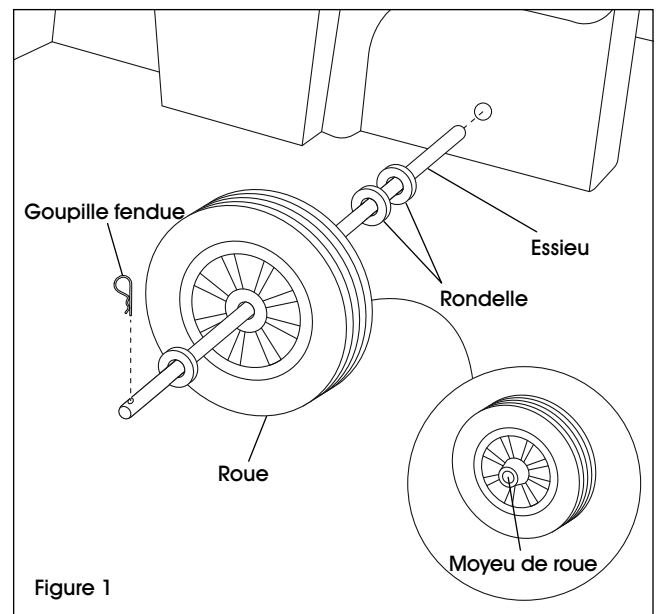

## MONTAGE SUITE

- Insérez la goupille fendue dans l'extrémité de l'essieu. Pliez l'extrémité de la goupille fendue pour la fixer. (Voir Figure 2)

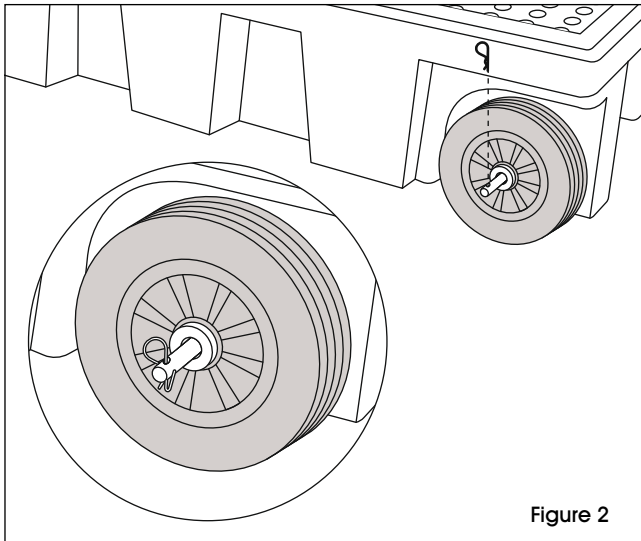

- Répétez les étapes 1 et 2 sur le côté opposé.

### ENSEMBLE DE LA POIGNÉE ET DES ROULETTES

- Placez la poignée dans les trous jusqu'à ce que les brides soient en contact avec la plateforme. (Voir Figure 3)

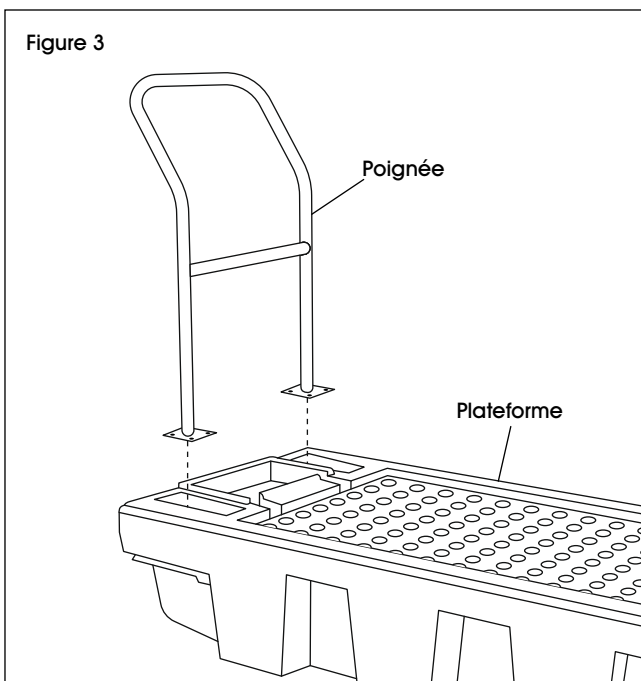

- Insérez les boulons à travers la bride de la poignée et la plateforme. (Voir Figure 4)
- Alignez les roulettes avec les boulons qui dépassent du bas de la plateforme. (Voir Figure 4)
- Enfilez sans serrer un écrou à embase sur chacun des boulons. Ne serrez pas. (Voir Figure 4)

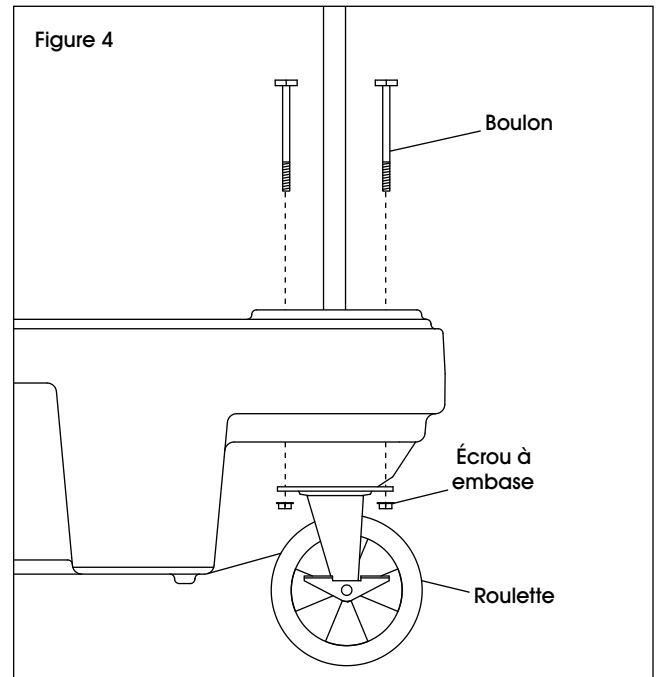

- Répétez les étapes 5 à 7 pour la roulette restante et le côté opposé de la poignée.
- Utilisez les clés de 1/2 po pour serrer les roulettes à la poignée.

**ULINE**

1-800-295-5510  
uline.ca