

ULINE H-11437, H-11438

DOWNTOWN COLLECTION

CABINETS WITH HUTCH

1-800-295-5510
 uline.com

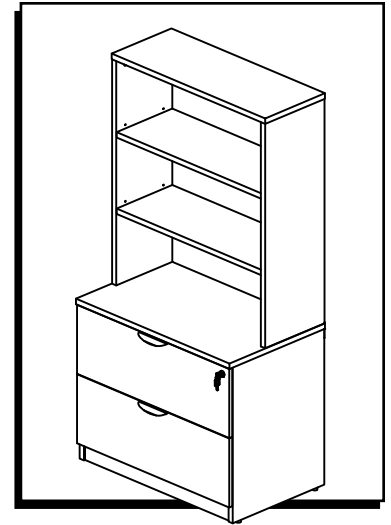

TOOLS NEEDED

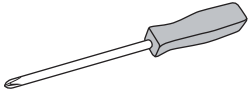

Phillips Screwdriver



Drill
 (Optional)



5/16" Drill Bit
 (Optional)



Two Person Assembly
 Recommended

PARTS

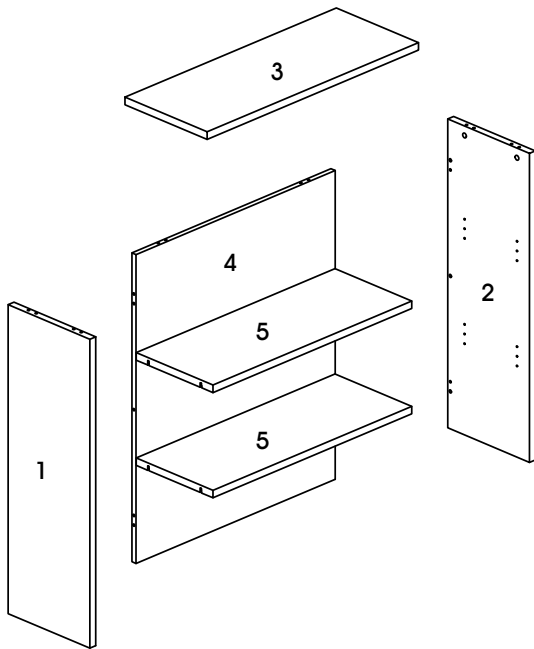

#	DESCRIPTION	QTY.
1	Left Side Panel	1
2	Right Side Panel	1
3	Top Panel	1
4	Back Panel	1
5	Shelf	2



NOTE: Assemble unit on a smooth, non-marring surface to prevent scratching. Check that all parts are included.



NOTE: Tighten all cam locks and bolts using Phillips screwdriver.

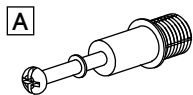

Cam Lock Pin x 12



Cam Lock x 12

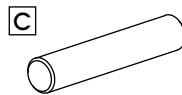

Dowel x 10

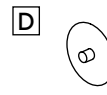

Cam Lock Cap x 12

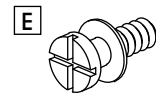

Shelf Dowel x 8

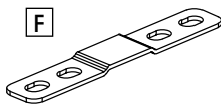

Hutch Bracket x 2



M6 x 15 mm
 Bolt x 4

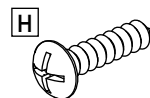

ST5 x 20 mm
 Screw x 4

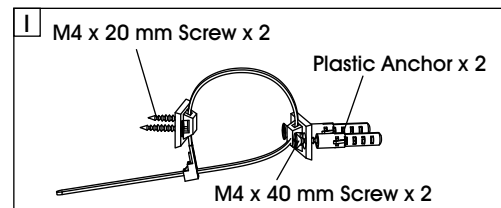

ASSEMBLY

1. Insert three cam lock pins (A) and two dowels (C) into the left side panel (1). Repeat on right side panel (2). (See Figure 1)

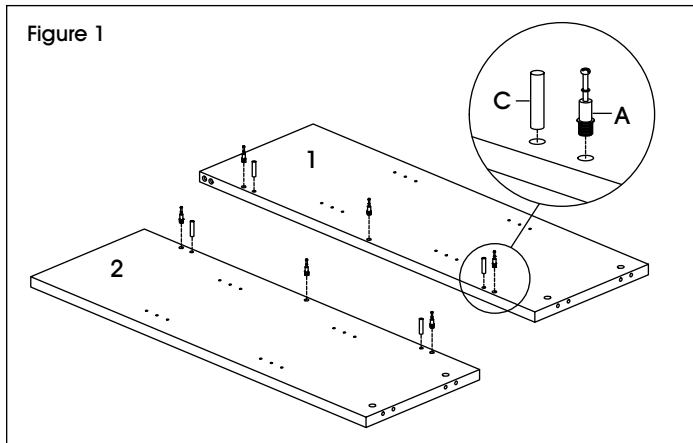

! **IMPORTANT!** Cam lock pins must be tightened once inserted into panel. Grasp lower part of cam lock pin and tighten using a Phillips head screwdriver.

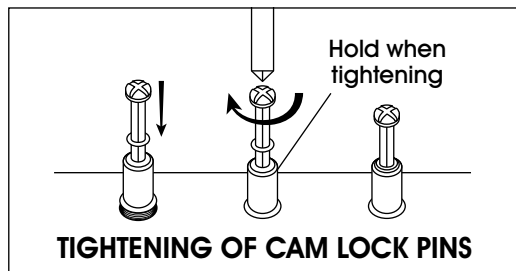

2. Insert six cam locks (B) into back side of back panel (4). (See Figure 2)

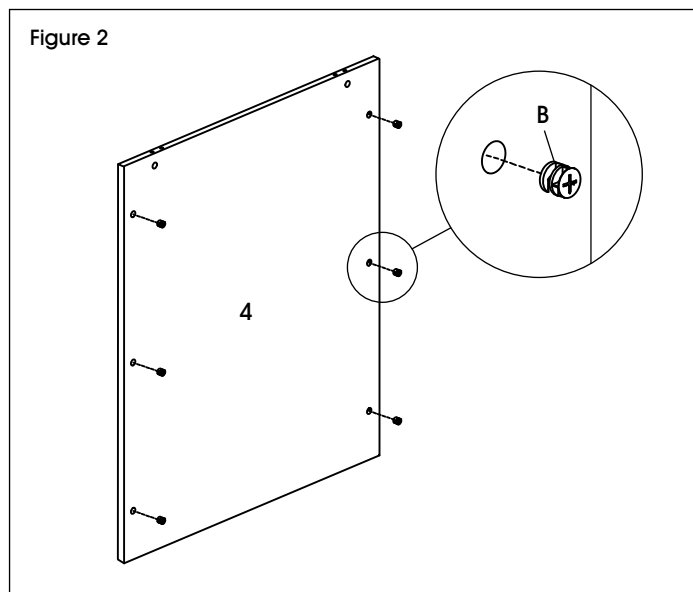

3. Attach side panels (1 and 2) to back panel (4). Tighten cam locks (B) on back side of back panel using Phillips screwdriver. (See Figures 3-4)

NOTE: Top edges of side and back panels include holes.

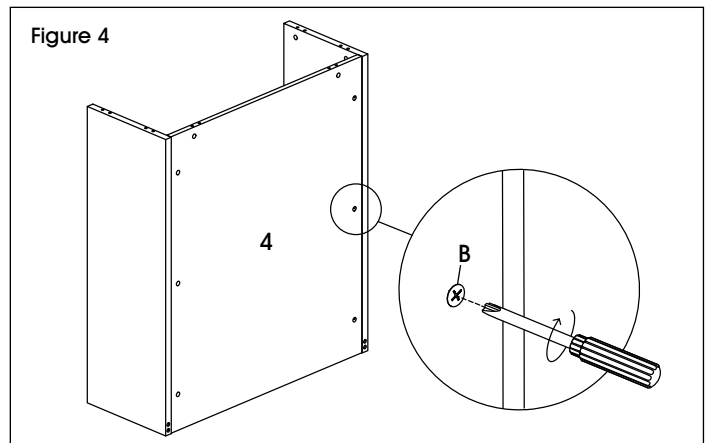
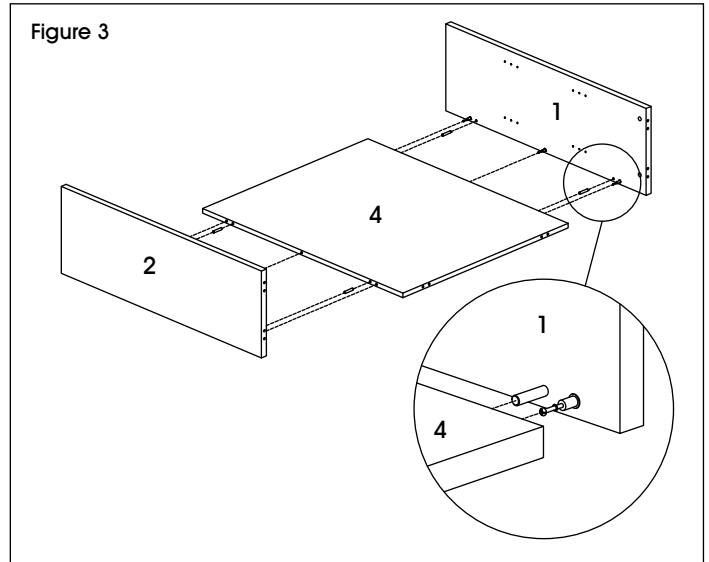

! **IMPORTANT!** Turn cam lock $\frac{1}{4}$ to the right to lock. Ensure the arrow is pointing to the edge of the panel before inserting into the panel's hole.

IMPORTANT! FUNCTION OF CAM LOCK

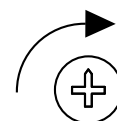

**1/4 RIGHT TURN
FOR LOCKING**

Ensure the arrow is pointing toward edge of panel before inserting into the panel's hole.

ASSEMBLY CONTINUED

4. Insert six cam lock pins (A) and six dowels (C) into top panel (3). Insert six cam locks (B) into side panels (1 and 2) and back panel (4). Attach top panel (3) to the cabinet body and tighten cam locks using a Phillips screwdriver. (See Figure 5)



NOTE: Once cam locks are tightened, cam lock caps (D) can be applied for a finished look.

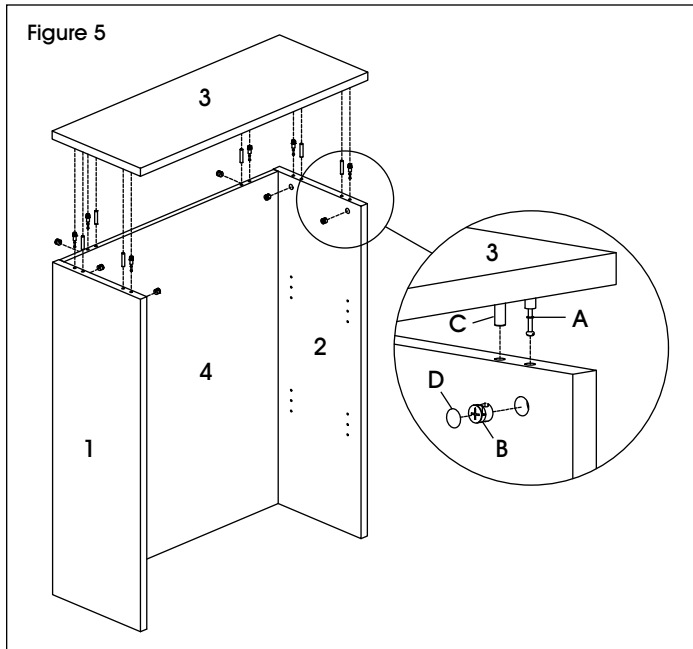

IMPORTANT! The following steps require an assembled H-6304GR Lateral File Cabinet or H-6859GR Storage Cabinet. Ensure the cabinet is placed near desired location before proceeding, but leave enough room to access the back of the unit.

5. With a second person, place hutch down on a smooth surface. Remove liner from double-sided tape on the bottom of each side panel (1 and 2). (See Figure 6)

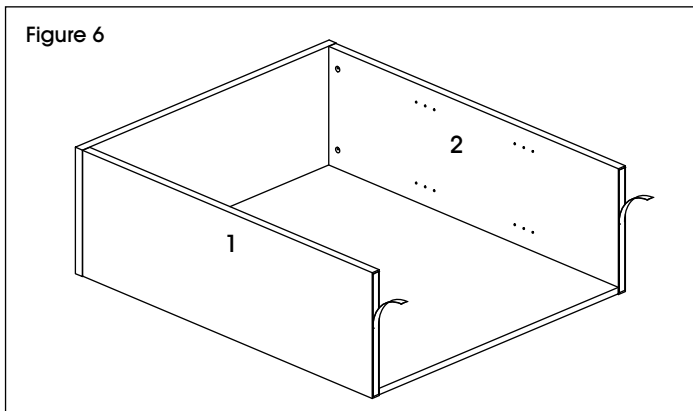

6. With a second person, carefully lift and place bookcase hutch on top of cabinet to ensure proper alignment at rear of cabinet. (See Figure 7)

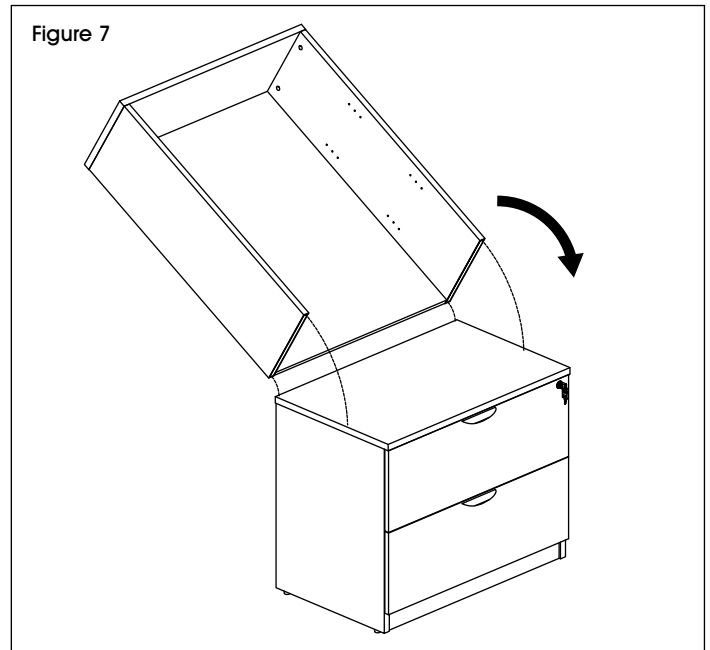

ASSEMBLY CONTINUED

7. Attach hutch bracket (F) to the back side of bookcase hutch using two M6 x 15 mm bolts (G) through top two slots on bracket. Repeat on opposite side of bookcase hutch. (See Figure 8)
8. Connect bookcase hutch to cabinet by installing two ST5 x 20 mm screws (H) through lower holes of hutch brackets (F). (See Figure 8)

 **NOTE:** ST5 x 20 mm screws (H) can be tightened using Phillips screwdriver or drill. If using drill, ensure it is set to lowest clutch setting.

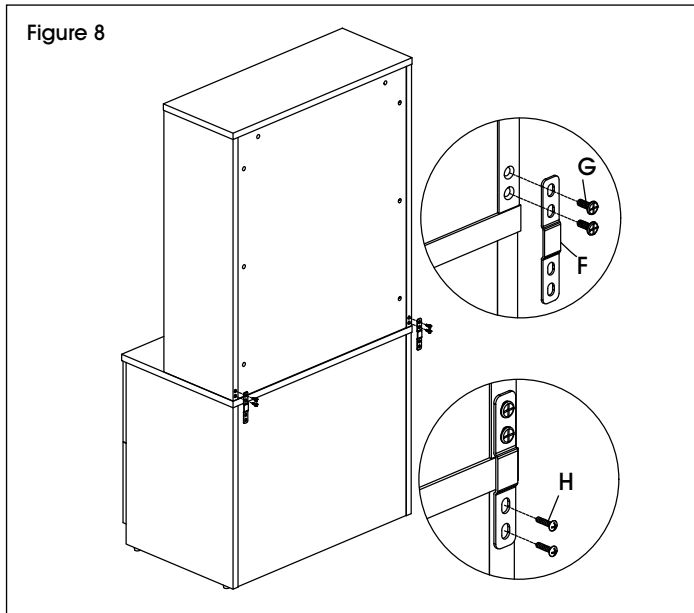

9. Insert shelf dowels (E) in desired locations on bookcase hutch. Place shelves (5) on top of shelf dowels. Tighten supports on underside of shelves for a secure fit. (See Figure 9)

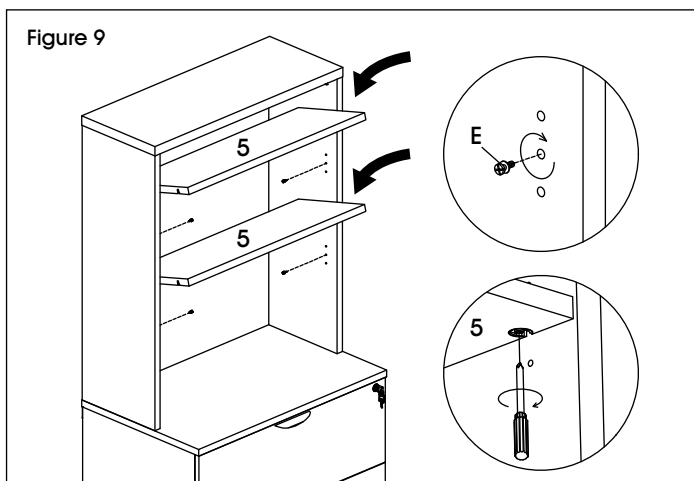

WALL ANCHOR (OPTIONAL)

1. Attach one bracket of wall anchor to back of top panel using two M4 x 20 mm screws (I). Mark holes on wall where plastic anchors are to be located. Drill holes using 5/16" drill bit. Mount opposite bracket of wall anchor to wall with two M4 x 40 mm screws and two plastic anchors (I). Tighten cable tie to prevent tipping. (See Figure 10)

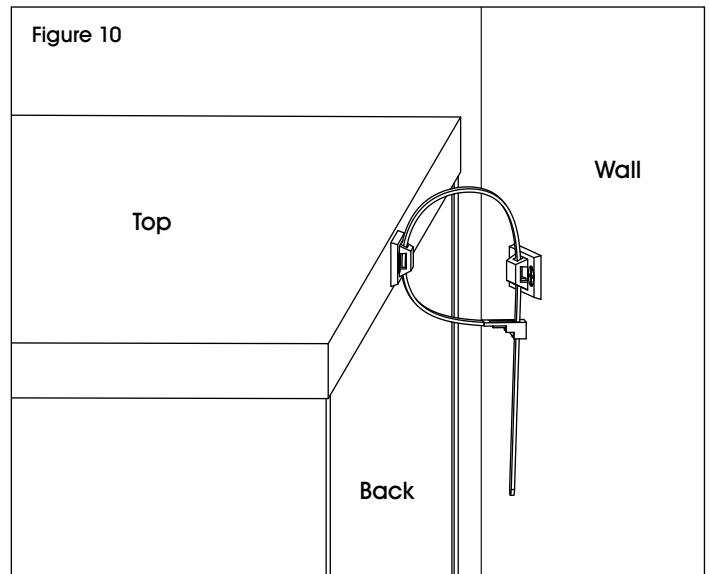

ULINE H-11437, H-11438

COLECCIÓN URBANA

GABINETES CON LIBRERO

800-295-5510

uline.mx

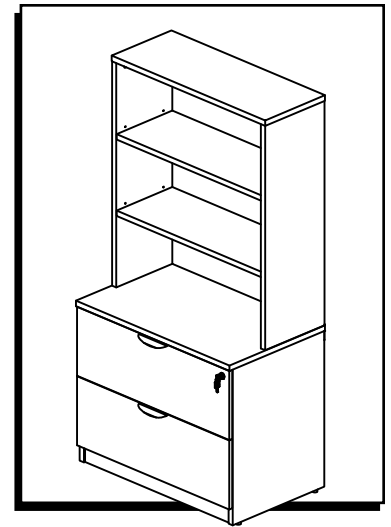

HERRAMIENTAS NECESARIAS

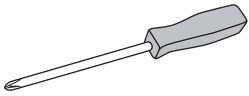

Desarmador de Cruz



Taladro (Opcional)



Broca de 5/16" (Opcional)



Se recomienda Armar Entre Dos Personas

PARTES

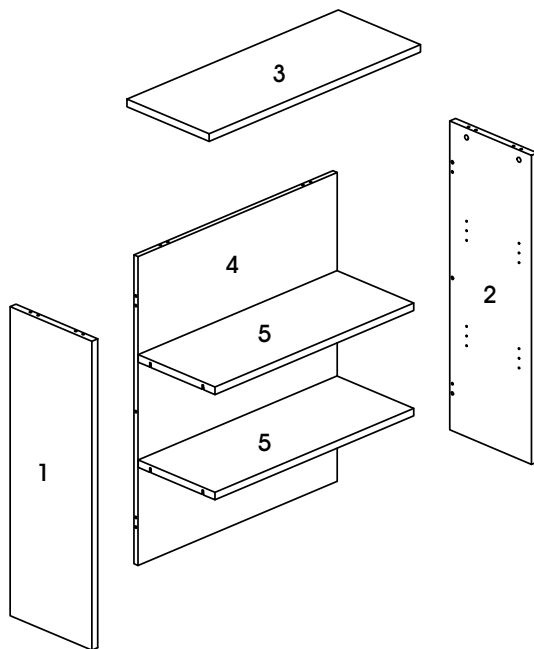

#	DESCRIPCIÓN	CANT.
1	Panel Lateral Izquierdo	1
2	Panel Lateral Derecho	1
3	Panel Superior	1
4	Panel Posterior	1
5	Repisa	2



NOTA: Ensamble la unidad sobre una superficie lisa que no deje marcas para evitar rayones. Verifique que todas las partes estén incluidas.



NOTA: Apriete todas las tuercas minifix y pernos utilizando el desarmador de cruz.

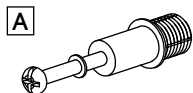

12 Pasadores para Tuercas Minifix



12 Tuercas Minifix

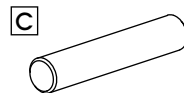

10 Taquetes

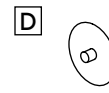

12 Tapas para Tuercas Minifix

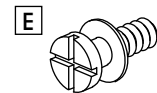

8 Taquetes para Repisa

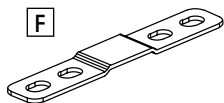

2 Soportes para Librero



4 Pernos M6 x 15 mm

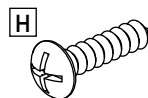

4 Tornillos ST5 x 20 mm

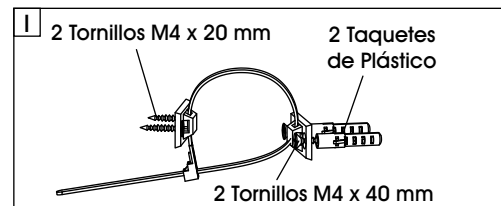

ENSAMBLE

1. Inserte tres pasadores para tuercas de leva (A) y dos taquetes (C) en el panel lateral izquierdo (1). Repita la operación con el panel lateral (2). (Vea Diagrama 1)

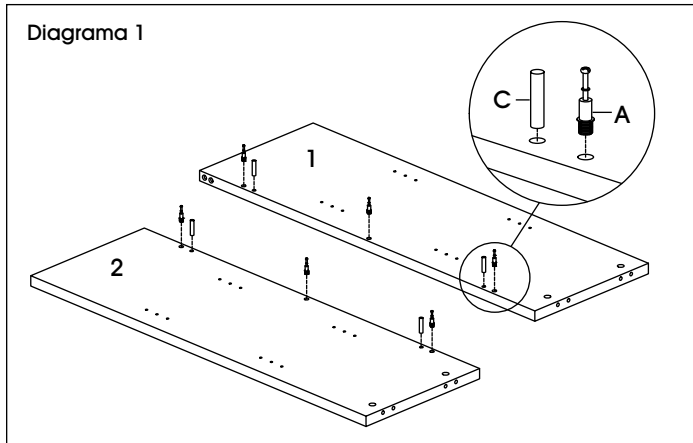

¡ **¡IMPORTANTE!** Los pasadores para tuercas minifix se deben apretar una vez se hayan insertado en el panel. Sostenga la parte inferior del pasador y apriete con el desarmador de cruz.

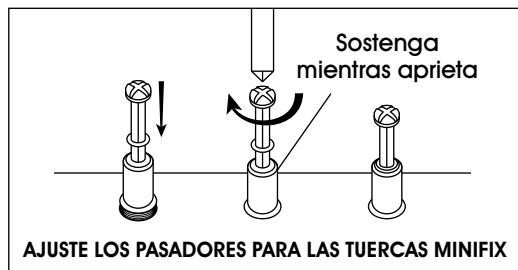

2. Inserte seis tuercas minifix (B) en el panel posterior (4). (Vea Diagrama 2)

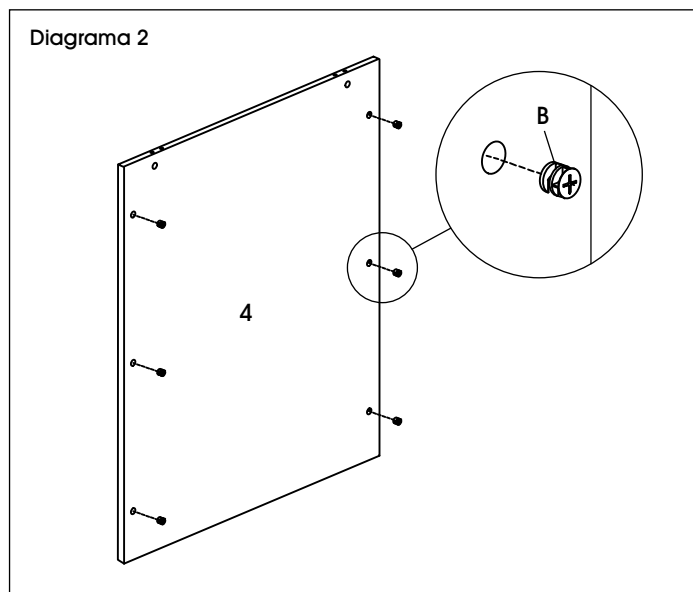

3. Fije los paneles laterales (1 y 2) al panel posterior (4). Apriete las tuercas minifix (B) en el panel posterior utilizando un desarmador de cruz. (Vea Diagramas 3-4)

NOTA: Los bordes superiores de los paneles laterales y posteriores incluyen los orificios.

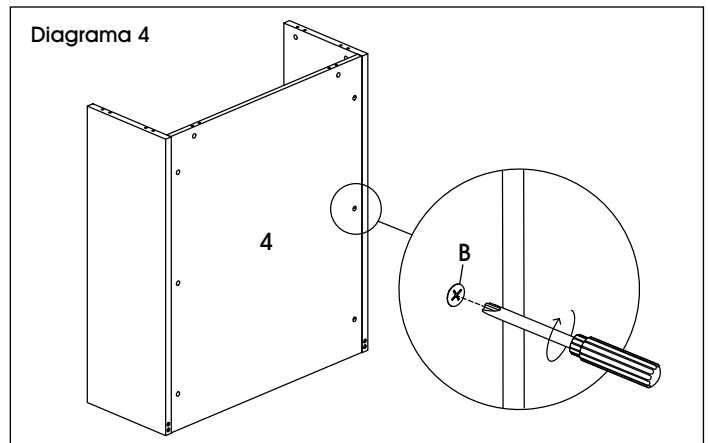
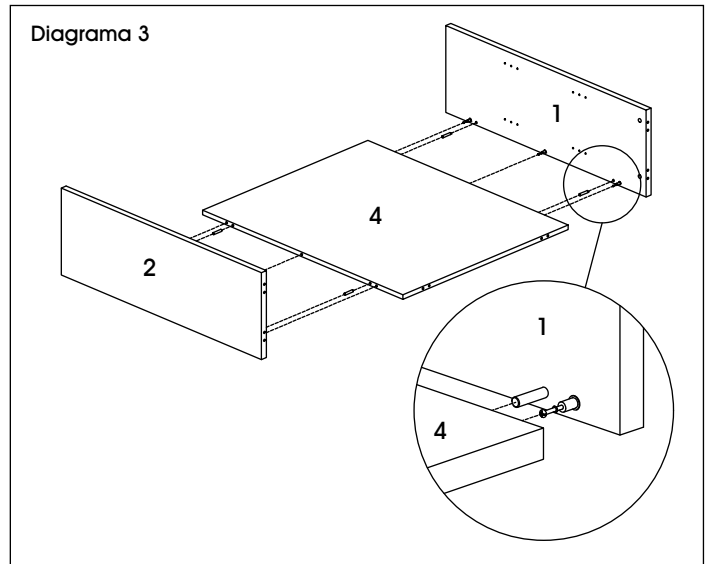

¡ **¡IMPORTANTE!** Gire la tuerca minifix $\frac{1}{4}$ a la derecha para asegurarla. Confirme que la flecha apunte hacia el borde del panel antes de insertarla en el orificio del panel.

¡IMPORTANTE! FUNCIÓN DE LA TUERCA MINIFIX

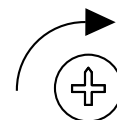

GIRE 1/4 A LA DERECHA PARA ASEGURARLA

Asegúrese de que la flecha apunte hacia el borde del panel antes de insertarlo en el orificio del panel.

CONTINUACIÓN DEL ENSAMBLE

- Inserte seis pasadores para tuercas minifix (A) y seis taquetes (C) en el panel superior (3). Inserte seis tuercas minifix (B) en los paneles laterales (1 y 2) y el panel posterior (4). Fije el panel superior (3) al cuerpo del gabinete y apriete las tuercas minifix con un desarmador de cruz. (Vea Diagrama 5)

 **NOTA:** Después de apretar las tuercas minifix, se pueden colocar las tapas de las tuercas minifix (D) para una apariencia terminada.

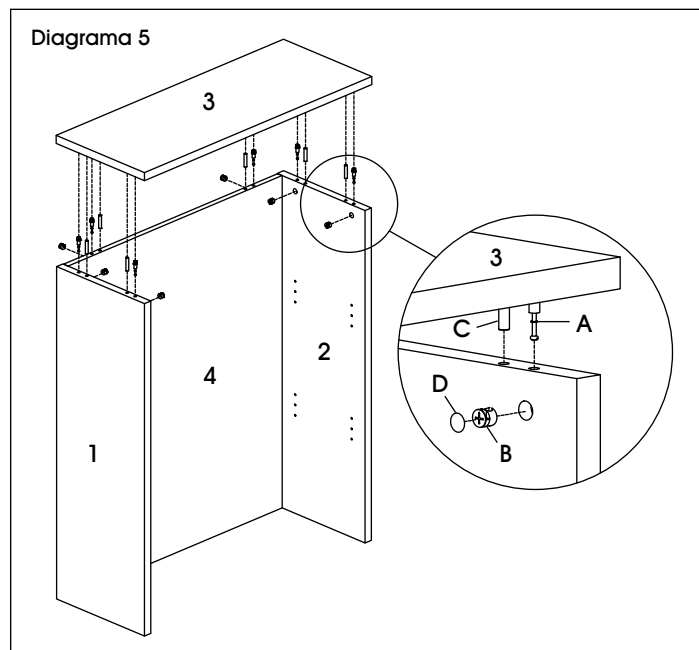

 **¡IMPORTANTE!** Los siguientes pasos requieren un Archivero Lateral H-6304GR o Gabinete de Almacenamiento H-6859GR. Asegúrese de que el gabinete se coloque cerca de la ubicación deseada antes de proceder, pero deje suficiente espacio para acceder a la parte posterior de la unidad.

- Con la ayuda de otra persona, coloque el librero sobre una superficie lisa. Retire el respaldo de la cinta doble cara en la parte inferior de cada panel lateral (1 y 2). (Vea Diagrama 6)

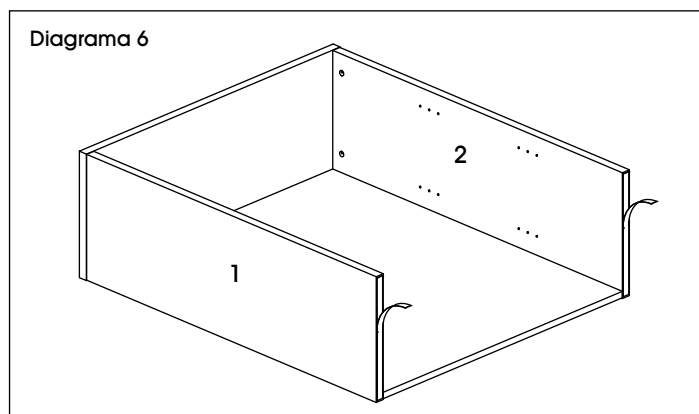

- Con la ayuda de una segunda persona, levante y coloque el librero con cuidado encima del gabinete para asegurar el alineamiento adecuado en la parte posterior del gabinete. (Vea Diagrama 7)

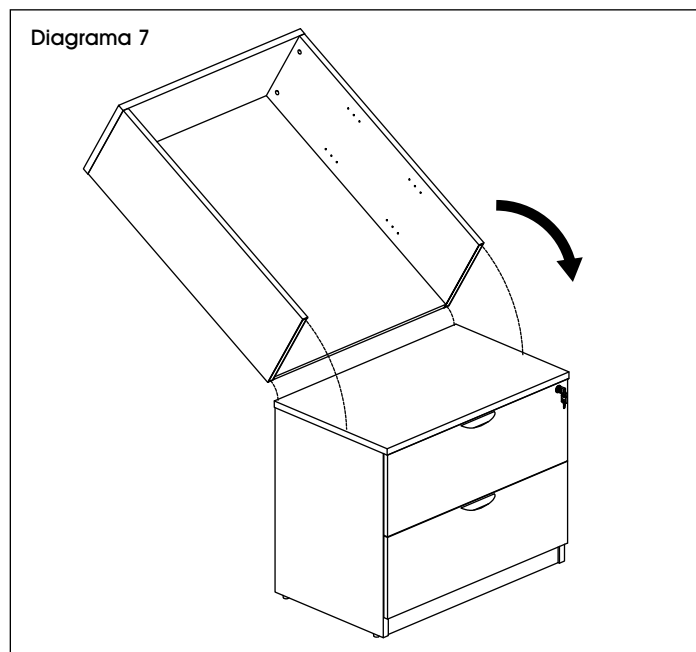

CONTINUACIÓN DEL ENSAMBLE

7. Fije el soporte del librero (F) a la parte posterior del librero utilizando dos pernos M6 x 15 mm (G) a través de las dos ranuras del soporte. Repita en el lado opuesto del librero. (Vea Diagrama 8)
8. Conecte el librero al gabinete instalando dos tornillos ST5 x 20 mm (H) a través de los orificios inferiores de los soportes para librero. (Vea Diagrama 8)

 **NOTA:** Los tornillos ST5 x 20 mm se pueden apretar utilizando un desarmador de cruz o taladro. Si utiliza un taladro, asegúrese de que esté puesto en la configuración de embrague.

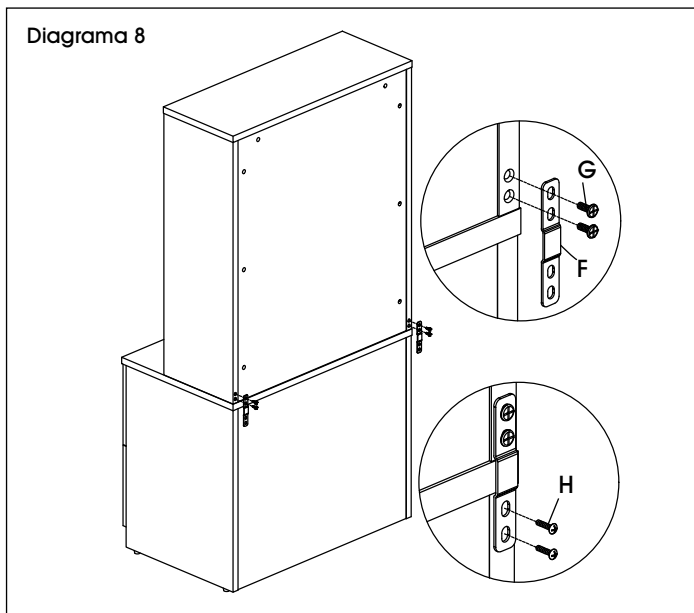

9. Inserte taquetes para repisa (E) en las ubicaciones deseadas del librero. Coloque las repisas (5) sobre los taquetes de las repisas. Apriete los soportes debajo de las repisas para un ajuste seguro. (Vea Diagrama 9)

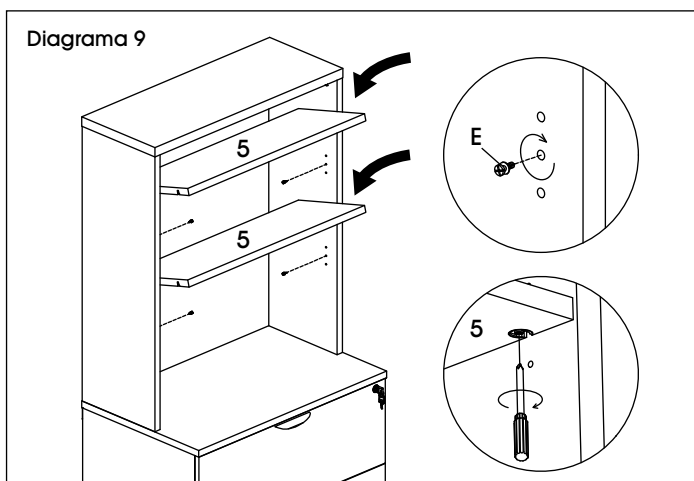

ANCLAJE PARA PARED (OPCIONAL)

1. Fije un soporte del anclaje para pared a la parte posterior del panel superior con dos tornillos M4 x 20 mm (I). Marque los orificios en la pared donde se colocarán los taquetes de plástico. Taladre los orificios utilizando una broca de 5/16". Instale el soporte opuesto del anclaje para pared con dos tornillos M4 x 40 mm y dos anclajes de plástico (I). Apriete el cincho para evitar que se vuelque. (Vea Diagrama 10)

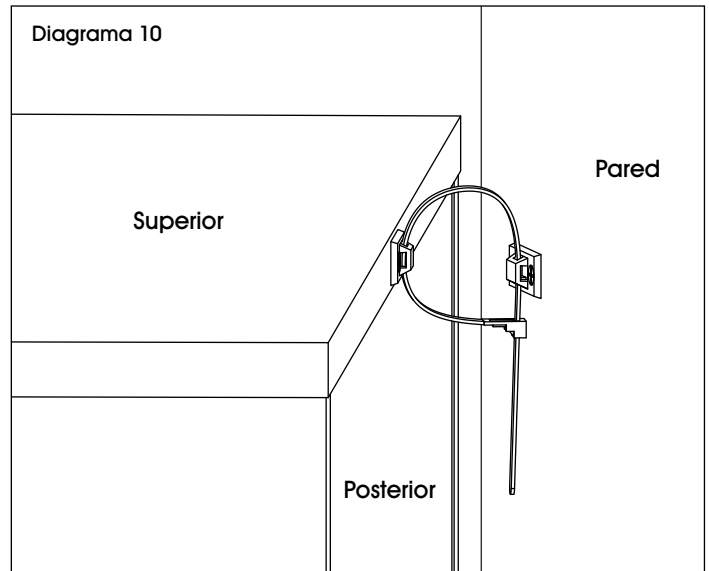

ULINE H-11437, H-11438
COLLECTION DOWNTOWN
 ARMOIRES AVEC HUCHE

1-800-295-5510
 uline.ca

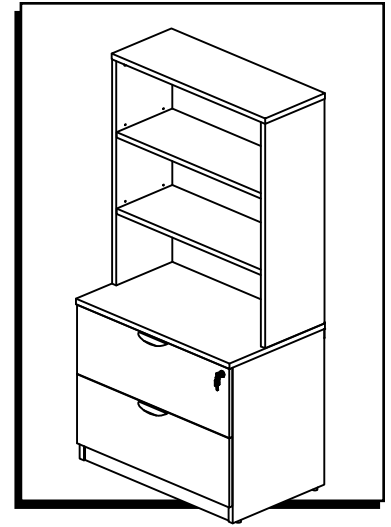

OUTILS REQUIS

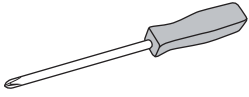

Tournevis cruciforme



Perceuse (optionnel)



Mèche de perceuse de 5/16 po (optionnel)



Montage à deux personnes recommandé

PIÈCES

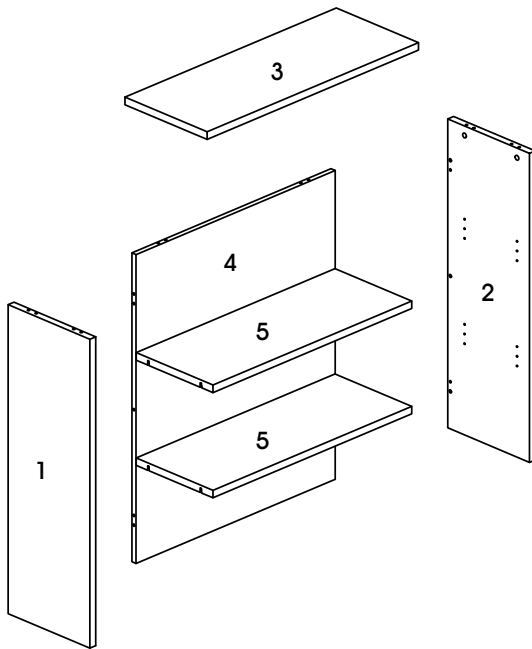

#	DESCRIPTION	QTÉ
1	Panneau latéral gauche	1
2	Panneau latéral droit	1
3	Panneau supérieur	1
4	Panneau arrière	1
5	Tablette	2



REMARQUE : Montez le meuble sur une surface lisse qui ne marque pas afin d'éviter les rayures. Vérifiez que toutes les pièces sont incluses.



REMARQUE : Serrez tous les excentriques et les boulons avec le tournevis cruciforme.

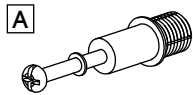

Goujon d'excentrique x 12



Excentrique x 12

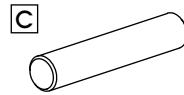

Cheville x 10

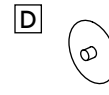

Cache pour excentrique x 12

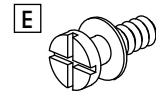

Cheville de tablette x 8

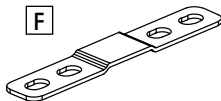

Support de huche x 2



Boulon M6 x 15 mm x 4

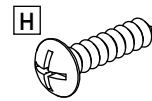

Vis ST5 x 20 mm x 4

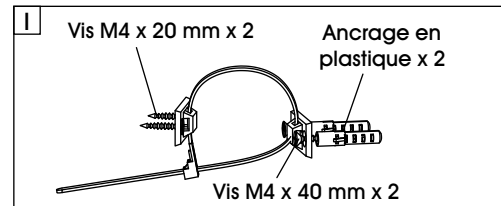

MONTAGE

1. Insérez trois goujons d'excentrique (A) et deux chevilles (C) dans le panneau latéral gauche (1). Répétez la procédure pour le panneau latéral droit (2). (Voir Figure 1)

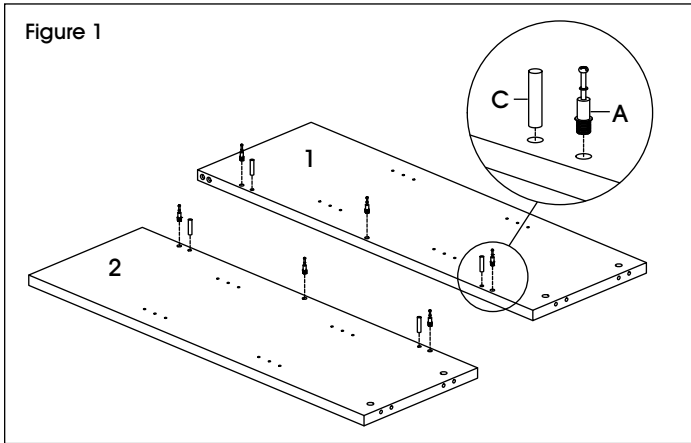

IMPORTANT! Les goujons d'excentrique doivent être serrés après insertion dans le panneau. Saisissez leur partie inférieure et serrez-les avec un tournevis cruciforme.

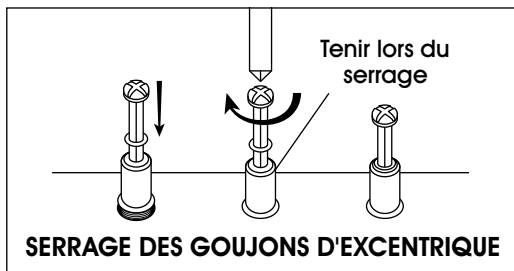

2. Insérez six excentriques (B) au dos du panneau arrière (4). (Voir Figure 2)

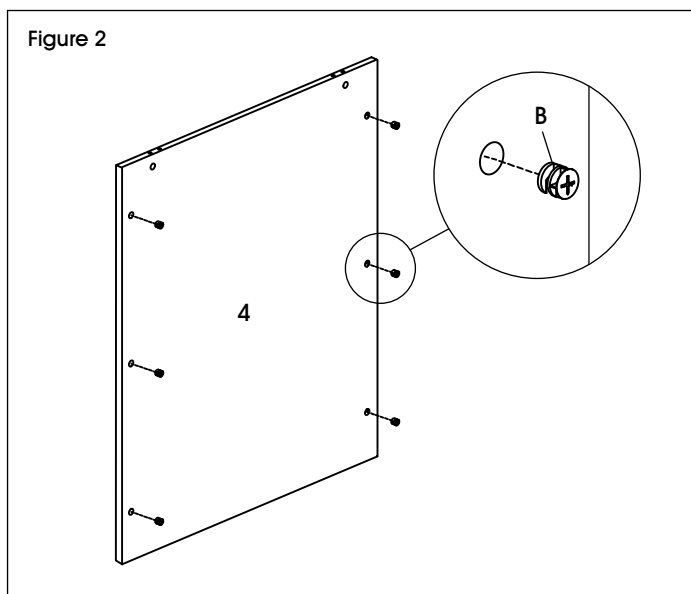

3. Fixez les panneaux latéraux (1 et 2) au panneau arrière (4). Serrez les excentriques (B) au dos du panneau arrière avec le tournevis cruciforme. (Voir Figures 3 et 4)

REMARQUE : Les bords supérieurs des panneaux latéraux et du panneau arrière comprennent des trous.

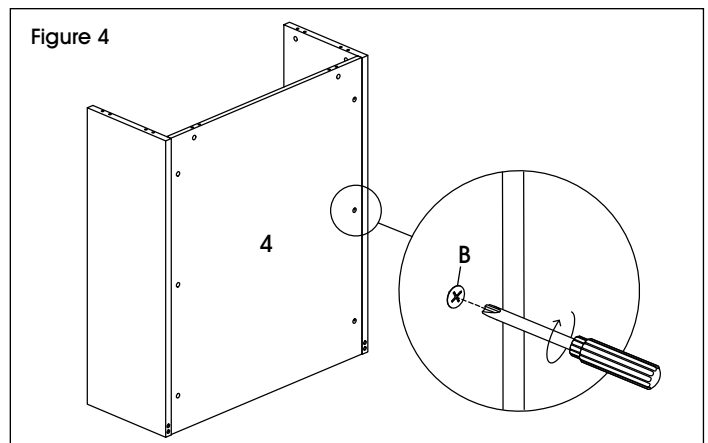
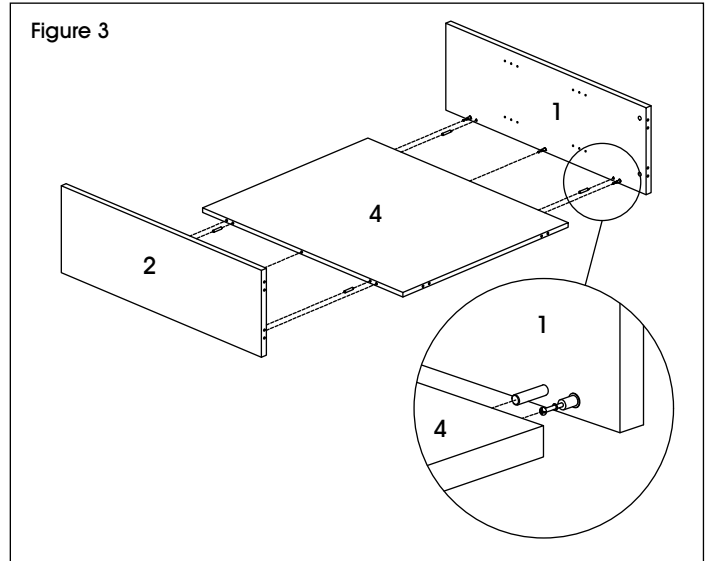

IMPORTANT! Tournez-l'excentrique de $\frac{1}{4}$ de tour vers la droite pour le verrouiller. Vérifiez que la flèche pointe vers le bord du panneau avant de l'insérer dans le trou du panneau.

IMPORTANT! UTILISATION DES EXCENTRIQUES

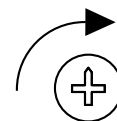

1/4 DE TOUR VERS LA DROITE POUR VERROUILLER

Vérifiez que la flèche pointe vers le bord du panneau avant de l'insérer dans le trou du panneau.

MONTAGE SUITE

- Insérez six goujons d'excentrique (A) et six chevilles (C) dans le panneau supérieur (3). Insérez six excentriques (B) dans les panneaux latéraux (1 et 2) et dans le panneau arrière (4). Fixez le panneau supérieur (3) au cadre de l'armoire et serrez les excentriques avec le tournevis cruciforme. (Voir Figure 5)



REMARQUE : Une fois que les excentriques ont été serrés, les caches pour excentrique (D) peuvent être installés pour donner un aspect fini.

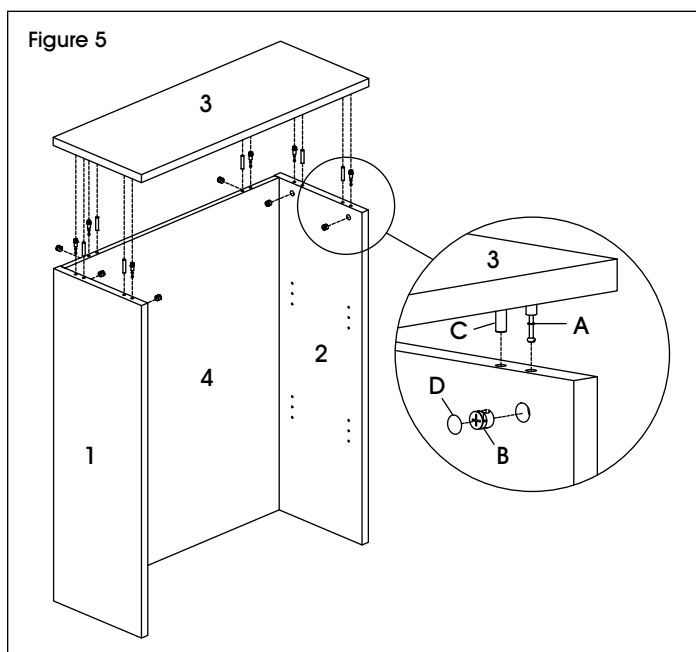

IMPORTANT! Les étapes suivantes exigent que le classeur latéral H-6304GR ou l'armoire de rangement H-6859GR soient assemblés. Avant de commencer, assurez-vous que l'armoire est placée près de l'emplacement souhaité en veillant de laisser assez d'espace pour accéder à l'arrière du meuble.

- À deux, posez la huche à plat sur une surface lisse. Enlevez la doublure du ruban adhésif double face sous les deux panneaux latéraux (1 et 2). (Voir Figure 6)

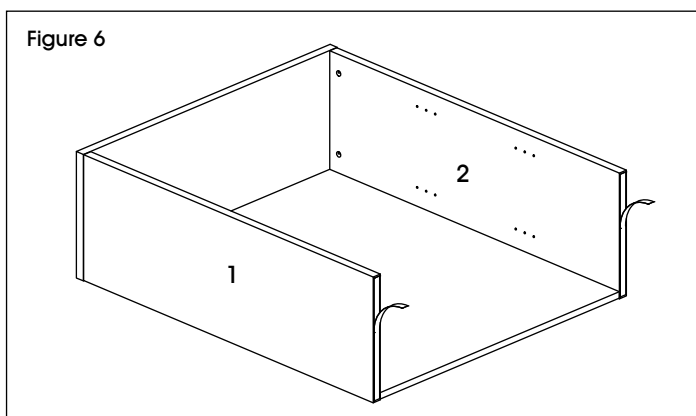

- À deux, soulevez la huche avec précaution et placez-la sur la surface de l'armoire en veillant de bien l'aligner sur le bord arrière. (Voir Figure 7)

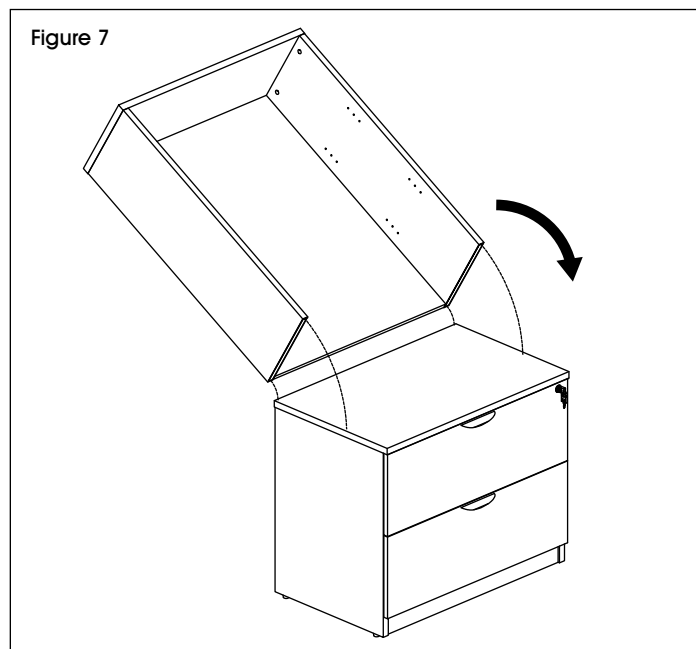

MONTAGE SUITE

- Fixez un support de huche (F) en insérant deux boulons M6 x 15 mm (G) à l'arrière de la huche à travers les deux fentes supérieures du support. Répétez la procédure pour l'autre côté de la huche. (Voir Figure 8)
- Fixez la huche à l'armoire en insérant deux vis ST5 x 20 mm (H) à travers les deux fentes inférieures des supports de huche (F). (Voir Figure 8)

 **REMARQUE :** Les vis ST5 x 20 mm (H) peuvent être serrées en vous servant d'un tournevis cruciforme ou d'une perceuse. Si vous optez pour la perceuse, réglez-la au réglage d'embrayage le plus bas.

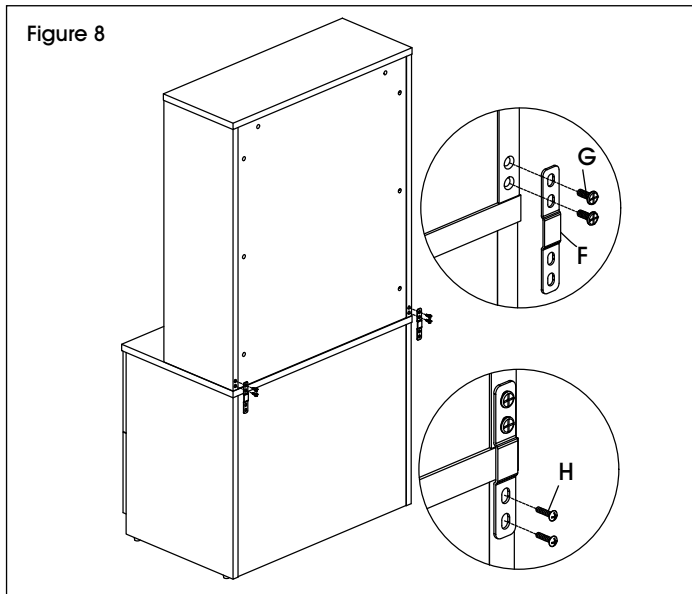

- Insérez les chevilles de tablette (E) aux emplacements souhaités dans la huche. Placez les tablettes (5) sur les chevilles. Serrez les supports situés sous les tablettes pour bien les ajuster. (Voir Figure 9)

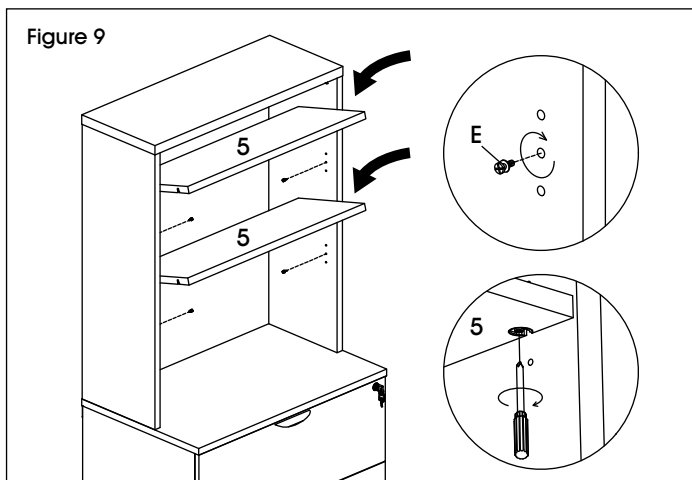

ANCRAGE MURAL (OPTIONNEL)

- Fixez un support d'ancrage mural à l'arrière du panneau supérieur en vous servant de deux vis M4 x 20 mm (I). Marquez l'emplacement des trous sur le mur pour les ancrages en plastique. Percez les trous en utilisant la mèche de perceuse de 5/16 po. Fixez l'autre support d'ancrage du côté opposé avec deux vis M4 x 40 mm et deux ancrages en plastique (I). Serrez l'attache-câble pour empêcher tout basculement. (Voir Figure 10)

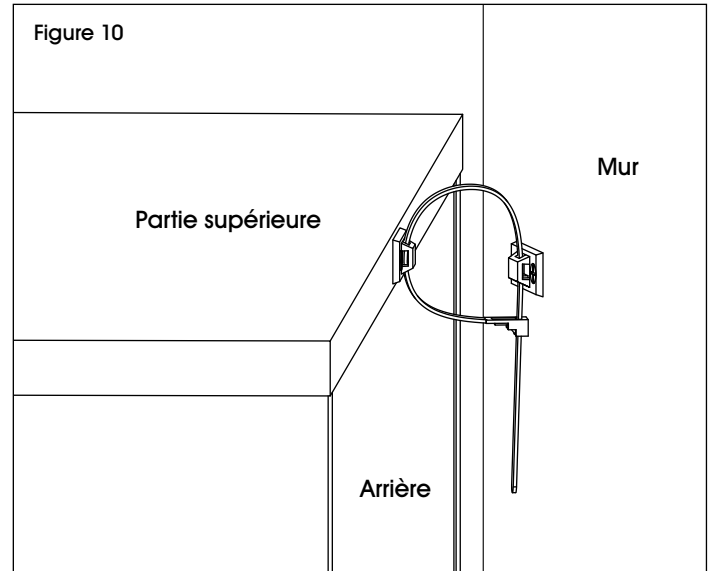

ULINE

1-800-295-5510
uline.ca