

# ULINE H-11453 TOP SHELF FOR Z-RACK

1-800-295-5510  
uline.com

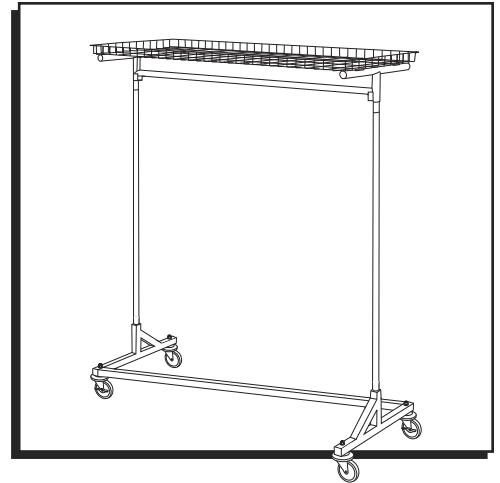

## TOOLS NEEDED

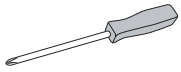

Phillips  
Screwdriver



Allen Wrench  
(included)



Wrench  
(optional)

## PARTS

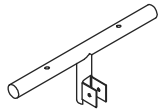

T-Bar x 2

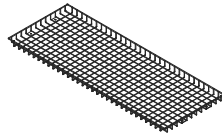

Shelf x 1



Small Bolt x 4

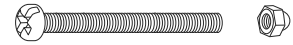

Large Bolt with Cap Nut x 2



**NOTE:** Small bolts come assembled on T-Bar.

## INSTALLATION

1. Attach T-Bars to top shelf using small bolts. Tighten with Allen wrench. (See Figure 1)

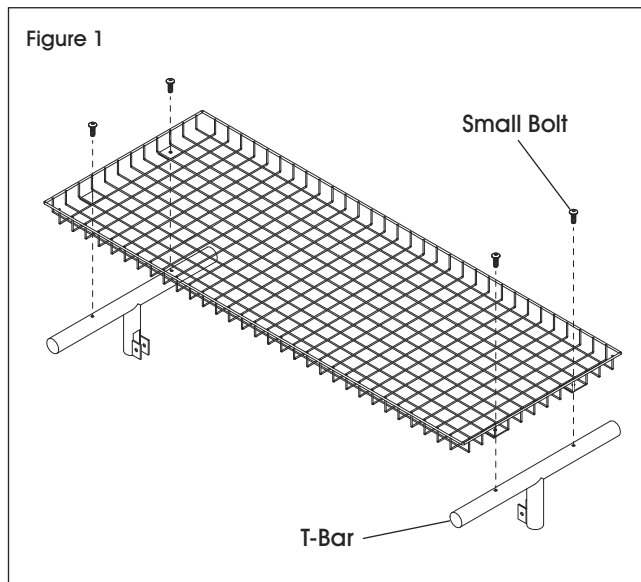

2. Slide assembled shelf onto Z-Rack. (See Figure 2)
3. Use large bolt and cap nut to secure shelf to Z-Rack. Tighten with Phillips screwdriver and wrench if needed. (See Figure 2)

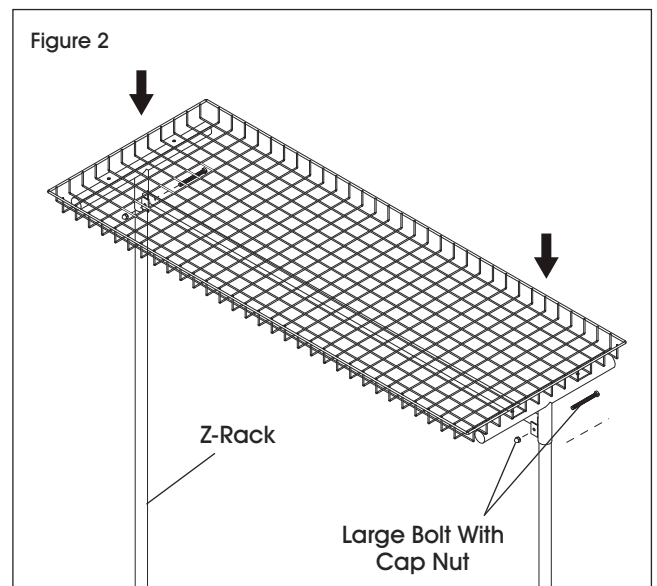

**ULINE** H-11453

# REPISA SUPERIOR PARA RACK EN Z

800-295-5510

uline.mx

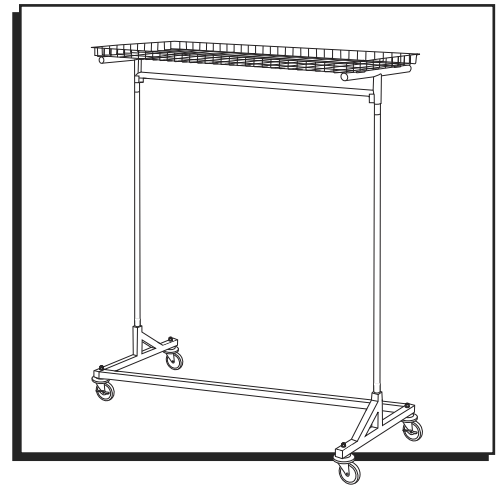

## HERRAMIENTAS NECESARIAS

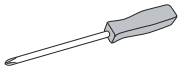

Desarmador de Cruz



Llave Allen (incluida)



Llave (opcional)

## PARTES

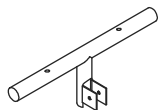

2 Barras en T

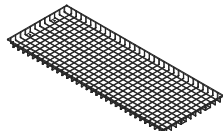

1 Repisa



4 Pernos Chicos

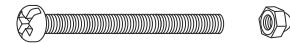

2 Pernos Largos con Tuerca de Tapón



**NOTA:** Los pernos chicos vienen ensamblados en la barra en T.

## INSTALACIÓN

1. Fije la Barras en T a la repisa superior usando los pernos chicos. Apriete con la llave Allen. (Vea Diagrama 1)

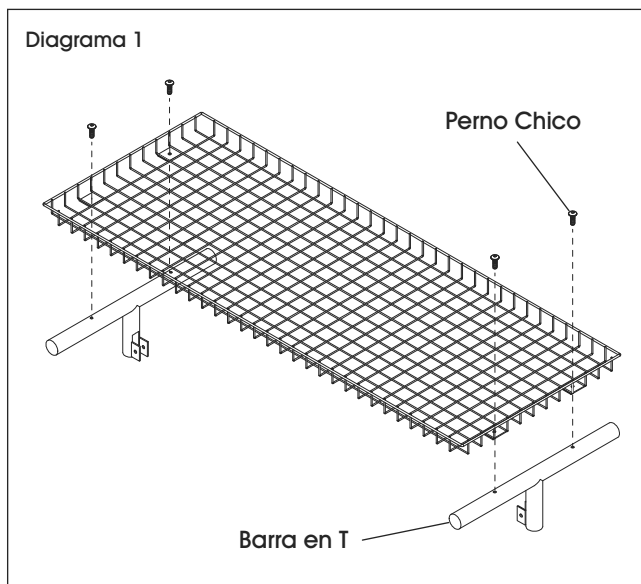

2. Inserte la repisa ensamblada sobre el Rack en Z. (Vea Diagrama 2)
3. Use un perno largo y una tuerca de tapón para fijar la repisa al Rack en Z. Apriete con un desarmador de cruz y una llave de ser necesario. (Vea Diagrama 2)

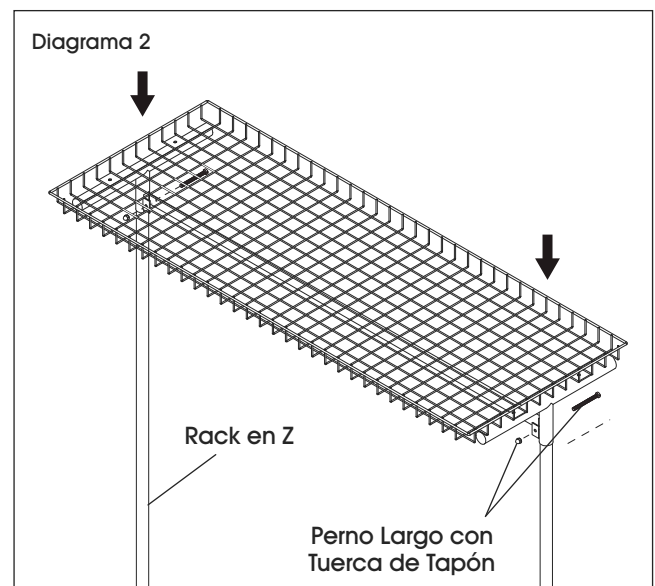

**ULINE** H-11453

# TABLETTE SUPÉRIEURE POUR SUPPORT EN Z

1-800-295-5510

uline.ca

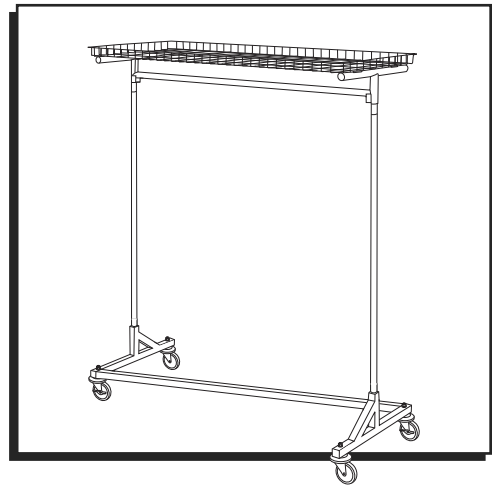

## OUTILS REQUIS

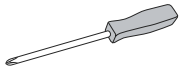

Tournevis  
cruziforme



Clé Allen  
(inclus)



Clé  
(en option)

## PIÈCES

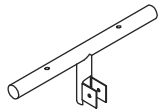

Barre en T x 2

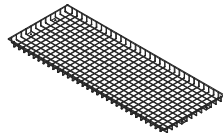

Tablette x 1



Boulon court x 4



Long boulon avec écrou borgne x 2



**REMARQUE :** Les boulons courts sont déjà assemblés sur les barres en T.

## INSTALLATION

1. Fixez les barres en T à la tablette supérieure avec les boulons courts. Serrez le tout avec la clé Allen. (Voir Figure 1)

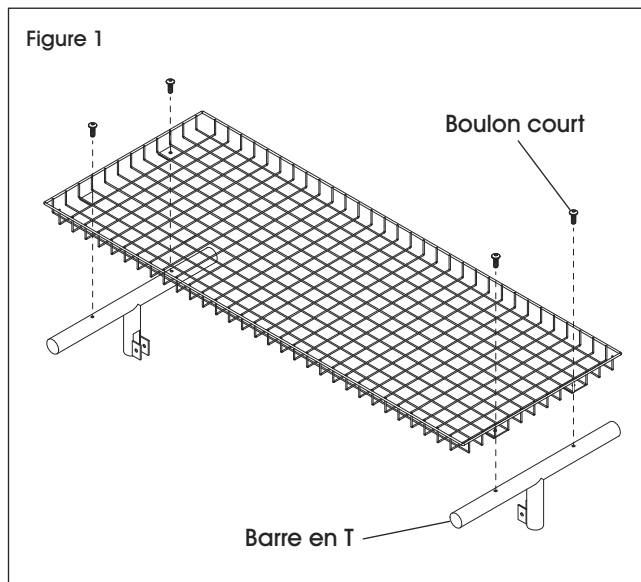

2. Insérez la tablette assemblée dans le support en Z. (Voir Figure 2)
3. Utilisez les longs boulons et les écrous borgnes pour fixer la tablette au support en Z. Serrez si nécessaire avec un tournevis cruciforme et une clé. (Voir Figure 2)

