

ULINE H-11486

MOBILE FLOOR STANDING SIGN HOLDER

1-800-295-5510
uline.com

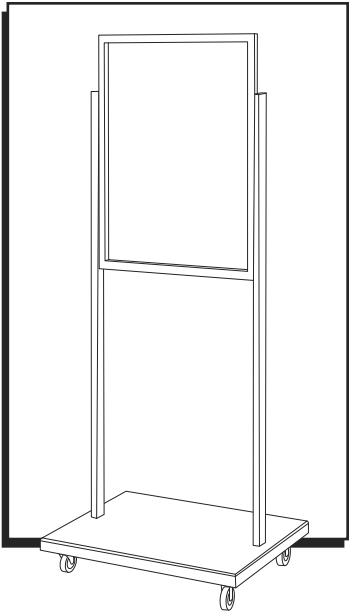

TOOLS INCLUDED



3 mm Allen Wrench
5 mm Allen Wrench



13 x 14 mm
Wrench

PARTS

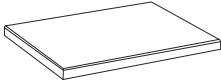

Base x 1

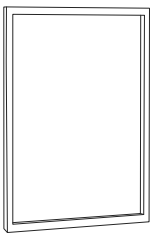

Frame x 1



Pole x 2



Caster x 4



Lock Washer x 4

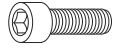

M4 x 12 mm Hex
Head Screw x 4

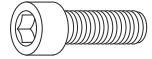

M6 x 35 mm Hex
Head Screw x 4

ASSEMBLY

1. Attach casters to base using lock washers. (See Figure 1)
2. Tighten casters using 13 x 14 mm wrench.

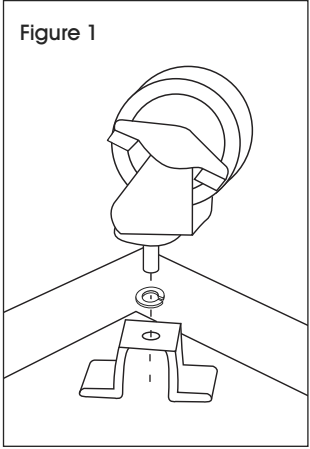

3. After all casters are secure, insert two M6 x 35 mm hex head screws inside the holes located underneath base between casters. Repeat on opposite side of base. (See Figure 2)

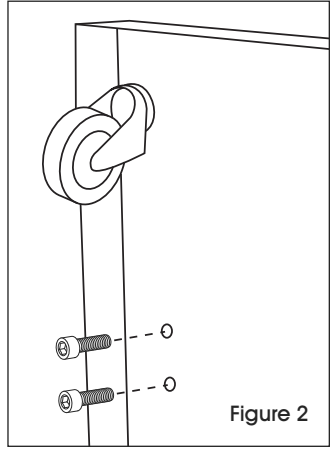

ASSEMBLY CONTINUED

4. Position threaded side of pole to align with holes on top of base. (See Figure 3)



NOTE: Poles have two holes for frame attachment that should face inward when attached to base. (See Figure 6)

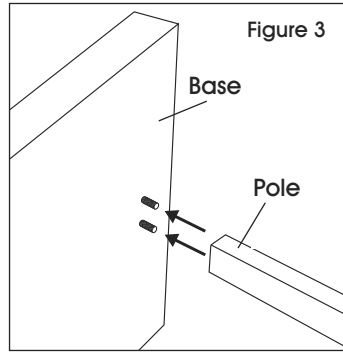

5. Tighten screws underneath the base using 5 mm Allen wrench.
6. Repeat steps 4 and 5 for other pole.
7. Stand unit upright. (See Figure 4)

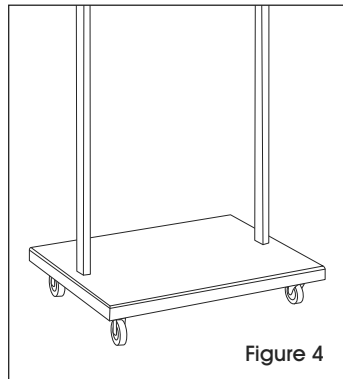

8. Position frame with open slot facing upward. (See Figure 5)
9. Align holes on interior of post with frame.

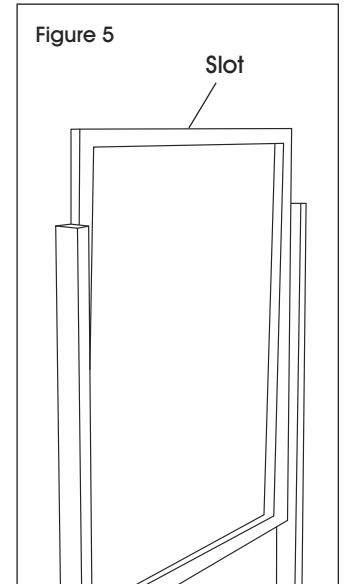

10. Insert two M4 x 12 mm screws through frame into post. (See Figure 6)
11. Tighten using 3 mm Allen wrench.
12. Repeat steps 10 and 11 for opposite side.

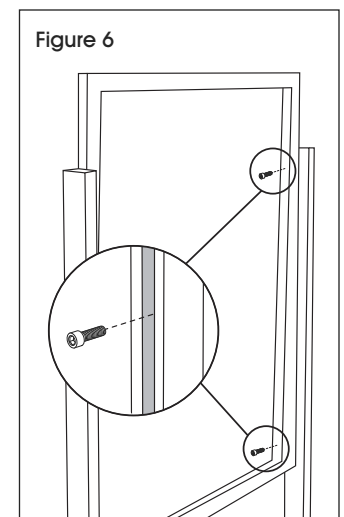

ULINE

1-800-295-5510
uline.com

ULINE H-11486 PORTALETRERO MÓVIL

800-295-5510
uline.mx

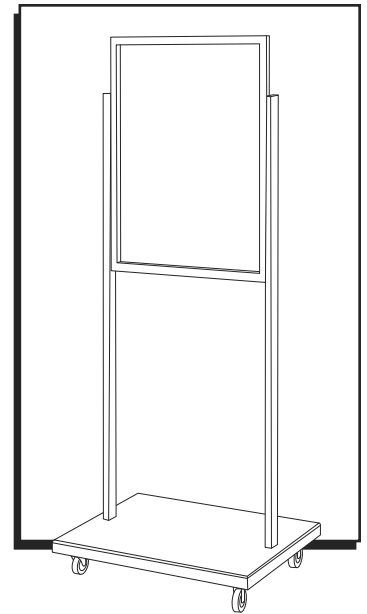

HERRAMIENTAS INCLUIDAS



Llave Allen de 3 mm
Llave Allen de 5 mm



Llave de 13 x 14 mm

PARTES

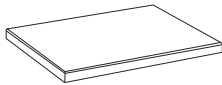

1 Base

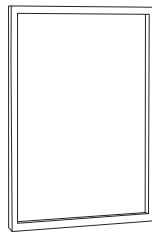

1 Armazón



2 Postes



4 Ruedas



4 Rondanas de Seguridad

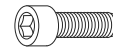

4 Tornillos de Cabeza Hexagonal M4 x 12 mm

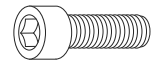

4 Tornillos de Cabeza Hexagonal M6 x 35 mm

ENSAMBLE

1. Fije las ruedas a la base utilizando las rondanas de seguridad. (Vea Diagrama 1)
2. Apriete las ruedas con una llave de 13 x 14 mm.

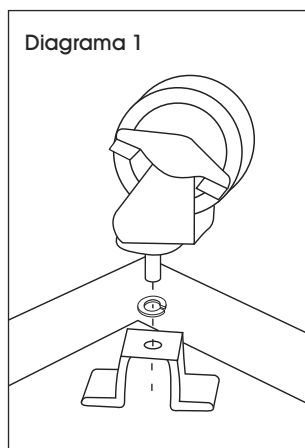

3. Después de asegurar todas las ruedas, inserte dos tornillos de cabeza hexagonal M6 x 35 mm en los orificios debajo de la base, entre las ruedas. Repita la operación en el lado opuesto de la base. (Vea Diagrama 2)

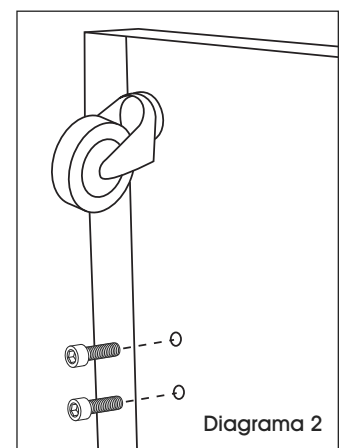

CONTINUACIÓN DEL ENSAMBLE

4. Alinee el lado roscado del poste con los orificios en la parte superior de la base. (Vea Diagrama 3)



NOTA: Los postes tienen dos orificios para fijar el accesorio que deben quedar hacia adentro cuando se fijen a la base. (Vea Diagrama 6)

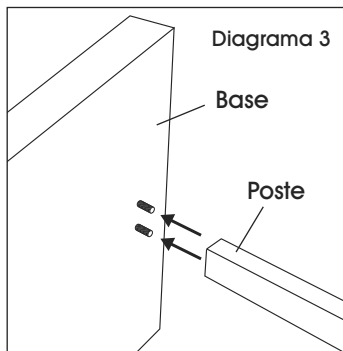

5. Apriete los tornillos debajo de la base con la llave Allen de 5 mm.
6. Repita los pasos 4 y 5 para el otro poste.
7. Coloque la unidad en posición vertical. (Vea Diagrama 4)

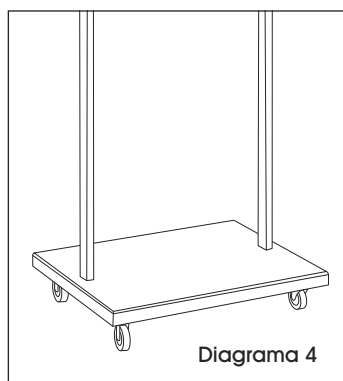

8. Coloque el armazón con la ranura abierta boca arriba. (Vea Diagrama 5)
9. Alinee los orificios en el interior del poste con el armazón.

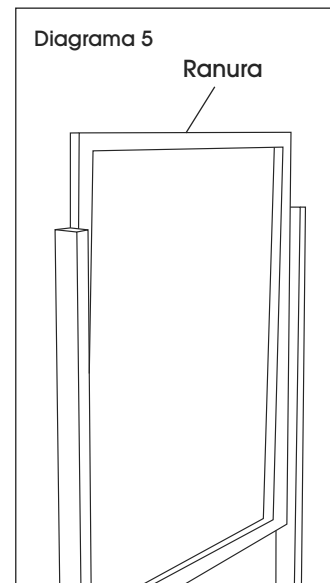

10. Inserte dos tornillos M4 x 12 mm en el poste, a través del armazón. (Vea Diagrama 6)
11. Apriete con la llave Allen de 3 mm.
12. Repita los pasos 10 y 11 en el lado opuesto.

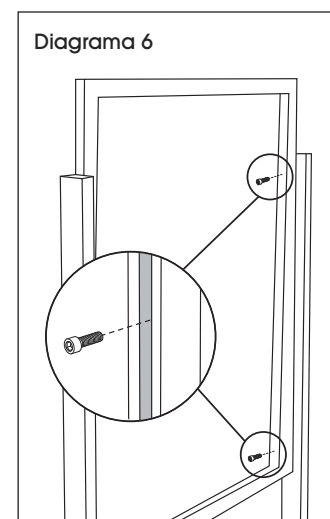

ULINE

800-295-5510
uline.mx

ULINE H-11486

SUPPORT D'ENSEIGNE SUR PIED MOBILE

1 800 295-5510
uline.ca

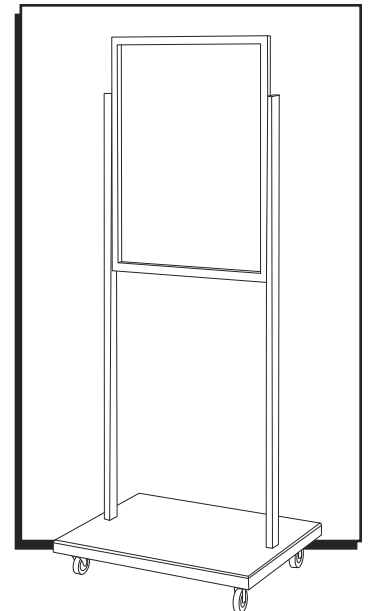

OUTILS INCLUS



Clé Allen de 3 mm
Clé Allen de 5 mm

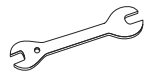

Clé de 13 x 14 mm

PIÈCES

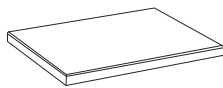

Base x 1

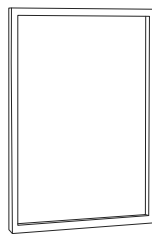

Cadre x 1



Poteau x 2



Roulette x 4



Rondelle de
blocage x 4

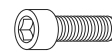

Vis à tête hexagonale
M4 x 12 mm x 4

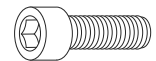

Vis à tête hexagonale
M6 x 35 mm x 4

MONTAGE

1. Installez les roulettes sur la base à l'aide des rondelles de blocage. (Voir Figure 1)
2. Fixez les roulettes avec la clé de 13 x 14 mm.

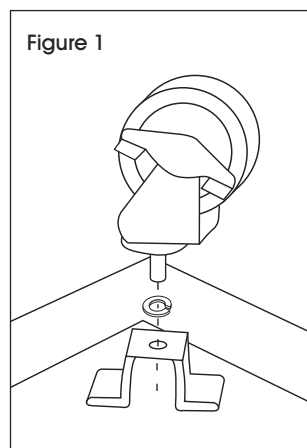

Figure 1

3. Une fois que les roulettes sont bien en place, insérez deux vis à tête hexagonale M6 x 35 mm dans les trous situés sous la base entre les roulettes. Répétez l'opération sur l'autre côté de la base. (Voir Figure 2)

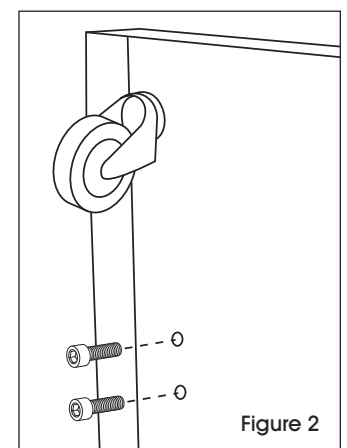

Figure 2

MONTAGE SUITE

4. Alignez le côté fileté du poteau sur les trous sur le dessus la base.
(Voir Figure 3)



REMARQUE : Les poteaux ont deux trous qui doivent être orientés vers l'intérieur lorsque fixés à la base.
(Voir Figure 6)

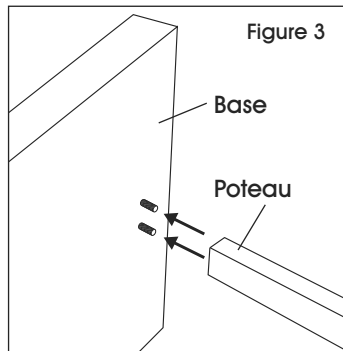

5. Serrez les vis sous la base avec la clé Allen de 5 mm.
6. Répétez les étapes 4 et 5 pour l'autre poteau.
7. Placez l'unité à la verticale.
(Voir Figure 4)

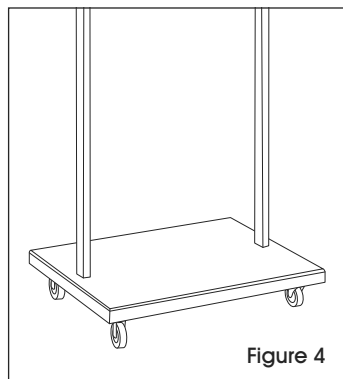

8. Positionnez le cadre avec l'ouverture de la fente orientée vers le haut. (Voir Figure 5)
9. Alignez les trous de la partie intérieure du poteau sur le cadre.

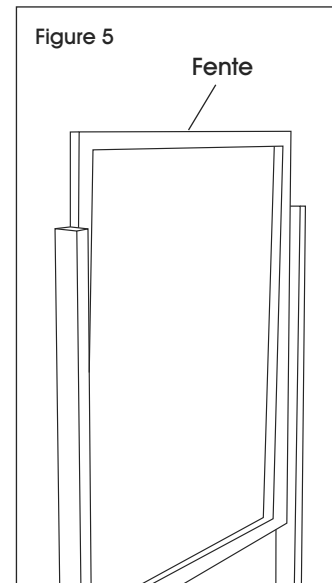

10. Insérez deux vis M4 x 12 mm à travers le cadre, puis dans le poteau. (Voir Figure 6)
11. Serrez le tout à l'aide de la clé Allen de 3 mm.
12. Répétez les étapes 10 et 11 sur le côté opposé.

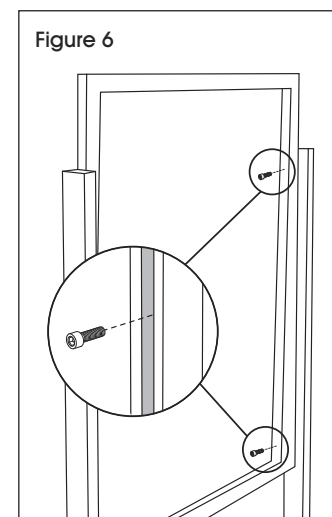

ULINE

1 800 295-5510
uline.ca