

# ULINE H-11621

## EXTENDED HANDLE URETHANE WHEEL CHOCK

1-800-295-5510  
uline.com

### TOOLS NEEDED



10 mm Wrench  
19 mm Wrench

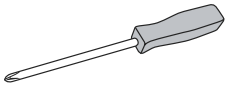

Phillips Screwdriver

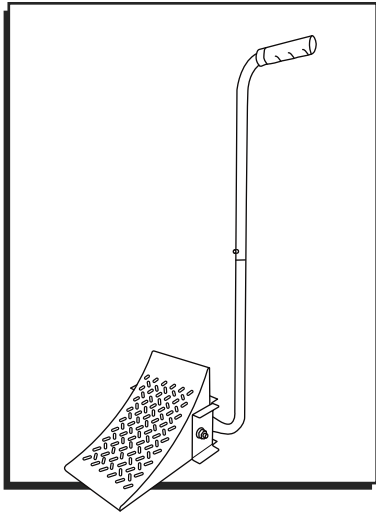

## PARTS

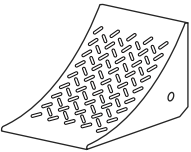

Wheel Chock x 1

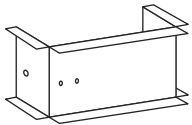

Bracket x 1

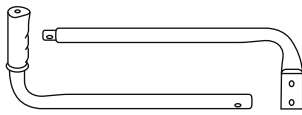

Handle x 1

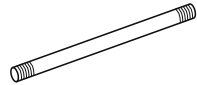

Rod x 1

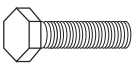

Small Bolt x 1



Locknut x 3



Flat Washer x 2



Lock Washer x 2



Large Nut x 2



Countersunk Screw x 2

## ASSEMBLY

1. Fit handle pieces together and align holes. Use small bolt and locknut to secure. Tighten with 10 mm wrench. (See Figure 1)

 **NOTE:** Determine if chock will be configured left- or right-handed before completing step 2. Instructions show right-handed setup.

2. Attach handle to bracket using countersunk screws and locknuts. Tighten with 10 mm wrench and Phillips screwdriver. (See Figure 2)

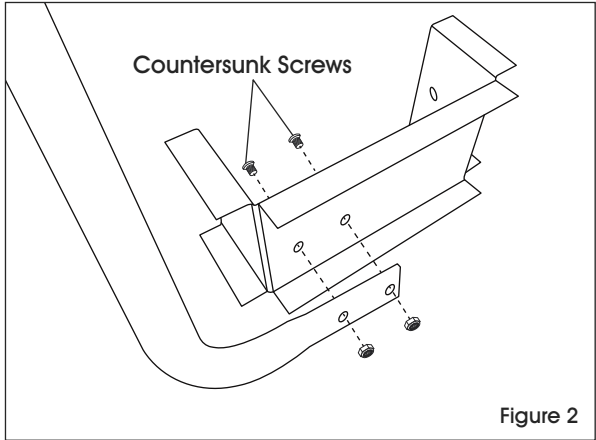
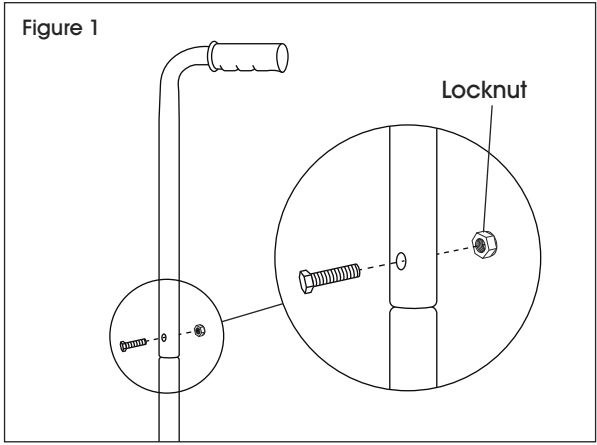

## ASSEMBLY CONTINUED

3. Place bracket around back of chock. (See Figure 3)

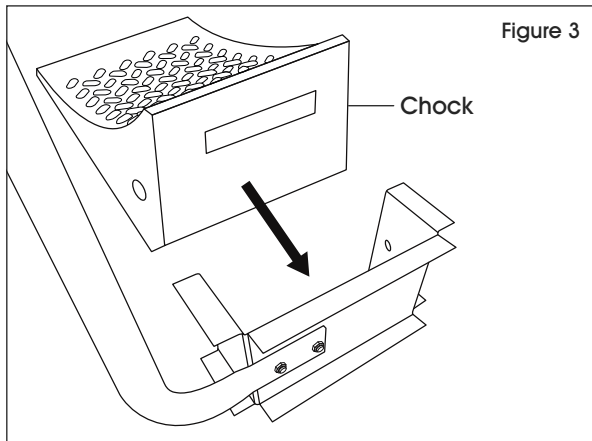

4. Align holes in bracket and wheel chock. Thread rod through to opposite side. (See Figure 4)

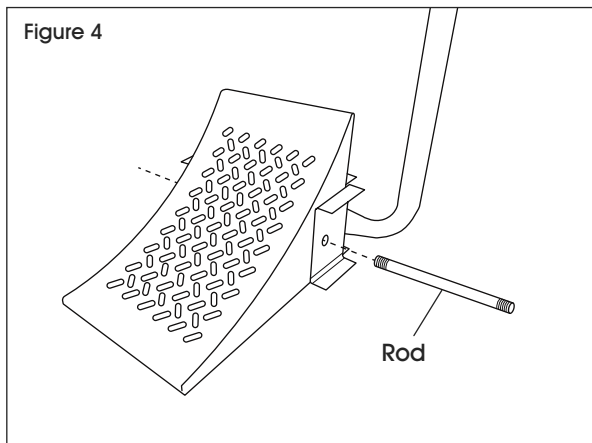

5. Secure both ends of rod with flat washer, lock washer and large nut. Tighten with 19 mm wrench. (See Figure 5)

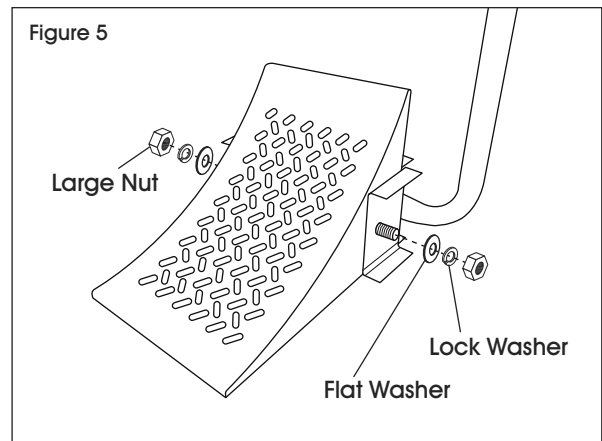

**ULINE H-11621**

# TOPE DE URETANO CON ASA LARGA PARA LLANTAS

800-295-5510

uline.mx

## HERRAMIENTAS NECESARIAS



Llave Inglesa de 10 mm  
Llave Inglesa de 19 mm

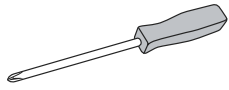

Desarmador de Cruz

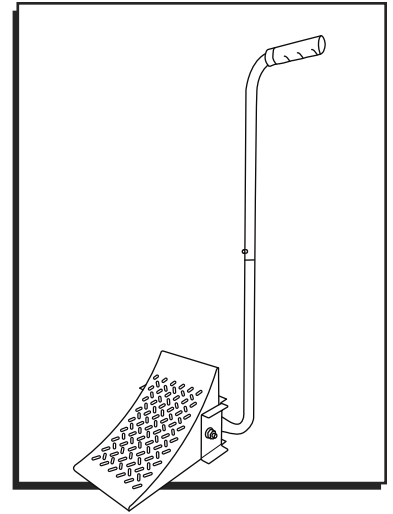

## PARTES

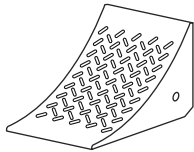

1 Tope para Llantas

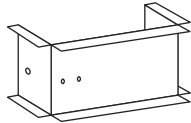

1 Soporte

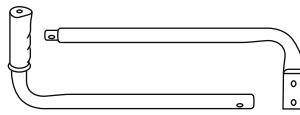

1 Asa



1 Varilla

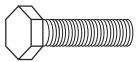

1 Perno Chico



3 Contratueras



2 Rondanas Planas



2 Rondanas de Seguridad



2 Tuercas Grandes



2 Tornillos Avellanados

## ENSAMBLE

1. Una las piezas del asa y alinee los orificios. Asegure con un perno chico y contratuerca. Apriete con una llave inglesa de 10 mm. (Vea Diagrama 1)



**NOTA:** Determine si el tope se configurará para zurdos o diestros antes de completar el paso 2. Las instrucciones muestran la configuración para diestros.

2. Fije el asa al soporte utilizando los tornillos avellanados y contratuercas. Apriete con una llave inglesa de 10 mm y desarmador de cruz. (Vea Diagrama 2)

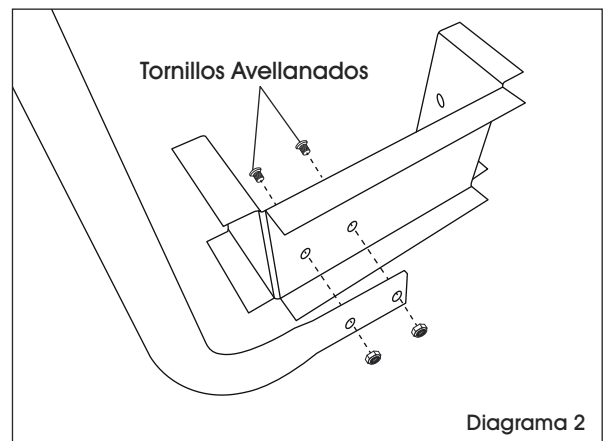
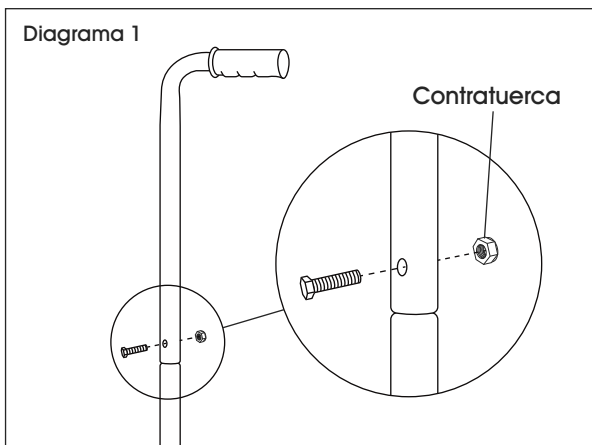

## CONTINUACIÓN DEL ENSAMBLE

3. Coloque el soporte alrededor de la parte posterior del tope. (Vea Diagrama 3)

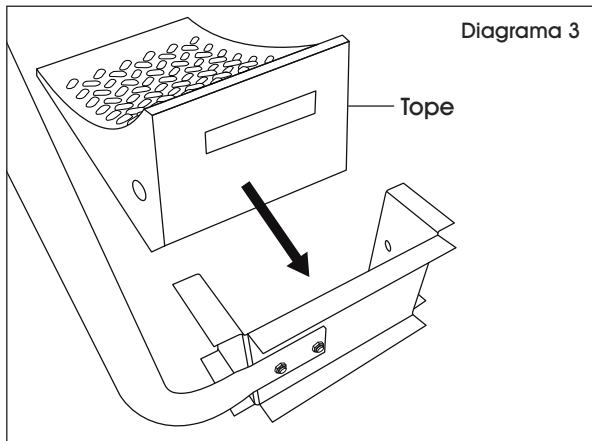

4. Alinee los orificios del soporte y del tope para llantas. Enrosque la varilla hacia el lado opuesto. (Vea Diagrama 4)

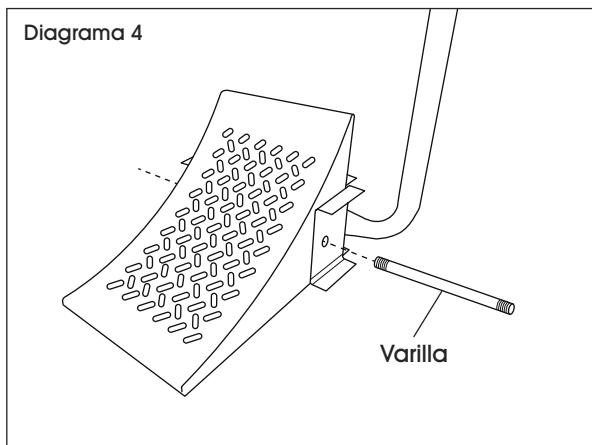

5. Asegure ambos extremos de la varilla con la rondana plana, rondana de bloqueo y tuerca grande. Apriete con una llave inglesa de 19 mm. (Vea Diagrama 5)

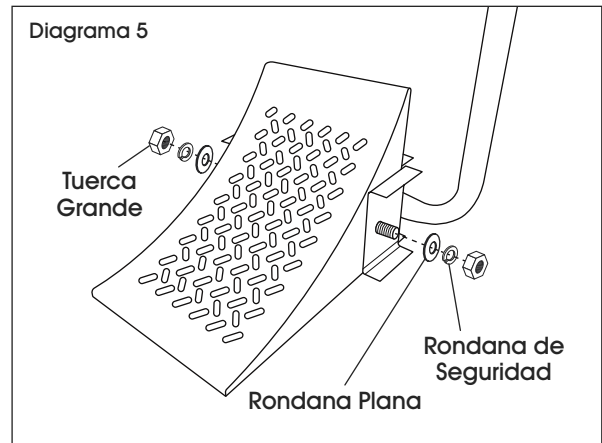

**ULINE** H-11621

# CALE DE ROUE EN URÉTHANE AVEC LONGUE POIGNÉE

1 800 295-5510

uline.ca

## OUTILS REQUIS



Clé de 10 mm  
Clé de 19 mm

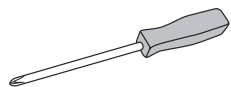

Tournevis cruciforme

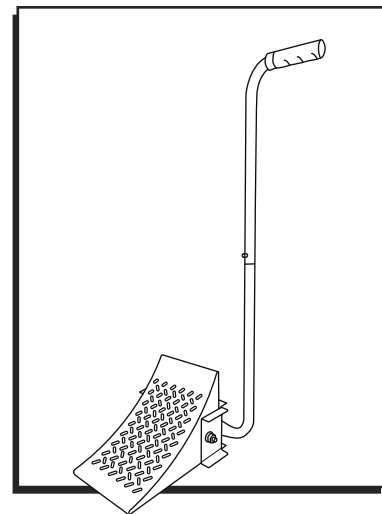

## PIÈCES

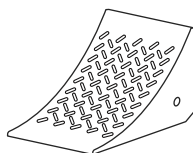

Cale de roue x 1

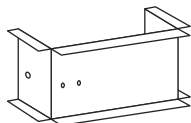

Support x 1

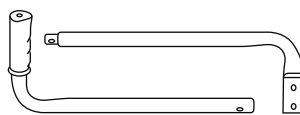

Poignée x 1

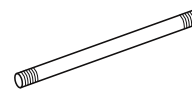

Tige x 1

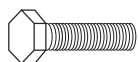

Boulon court x 1



Écrou de  
blocage x 3



Rondelle plate x 2



Rondelle de  
blocage x 2



Gros écrou x 2



Vis noyée x 2

## MONTAGE

1. Emboîtez les pièces de la poignée et alignez les trous. Fixez-les avec un boulon court et un écrou de blocage. Serrez avec la clé de 10 mm. (Voir Figure 1)

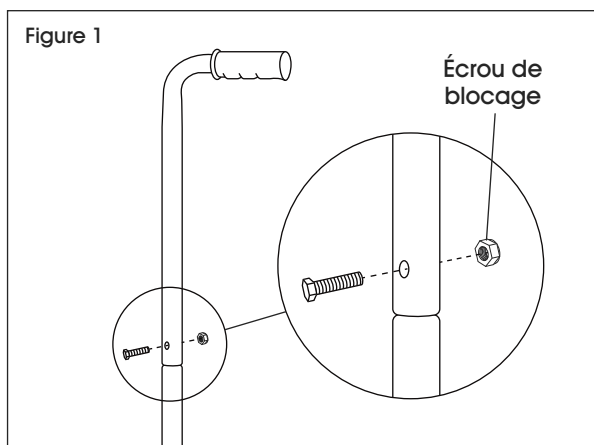

**REMARQUE :** Déterminez si la cale sera configurée pour gaucher ou droitier avant de compléter l'étape 2. Les instructions ci-dessous montrent la configuration pour droitier.

2. Fixez la poignée au support avec les vis noyées et les écrous de blocage. Serrez avec la clé de 10 mm et le tournevis cruciforme. (Voir Figure 2)

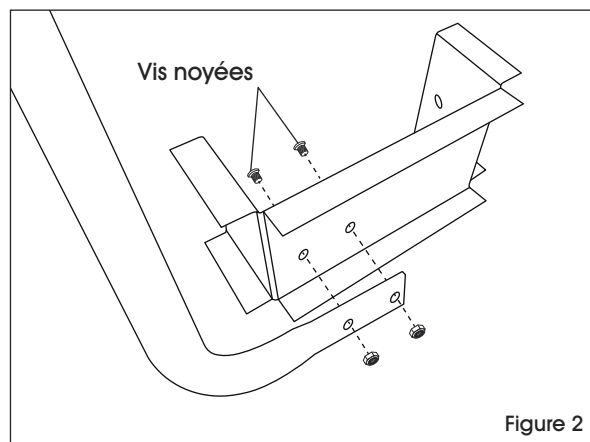

## MONTAGE SUITE

3. Placez le support à l'arrière de la cale. (Voir Figure 3)

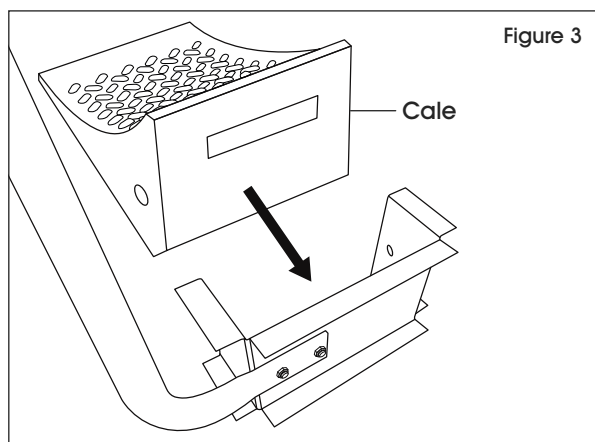

4. Alignez les trous du support et de la cale de roue. Enfoncez la tige jusqu'au côté opposé. (Voir Figure 4)

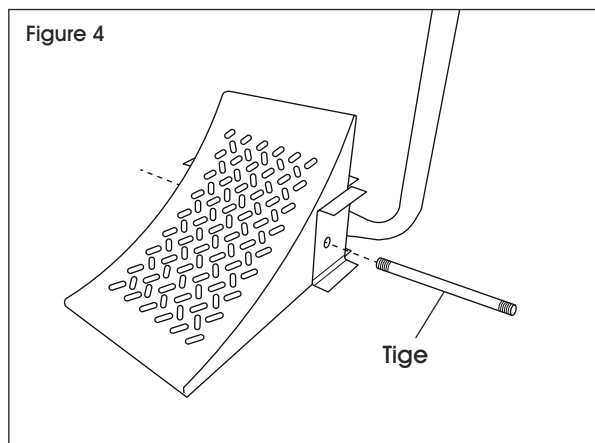

5. Fixez les deux extrémités de la tige avec une rondelle plate, une rondelle de blocage et un gros écrou de chaque côté. Serrez avec la clé de 19 mm. (Voir Figure 5)

