

# ULINE H-11622

## EXTENDED HANDLE LAMINATED WHEEL CHOCK

1-800-295-5510  
uline.com

### TOOLS NEEDED



- 11 mm Wrench
- 13 mm Wrench
- 14 mm Wrench

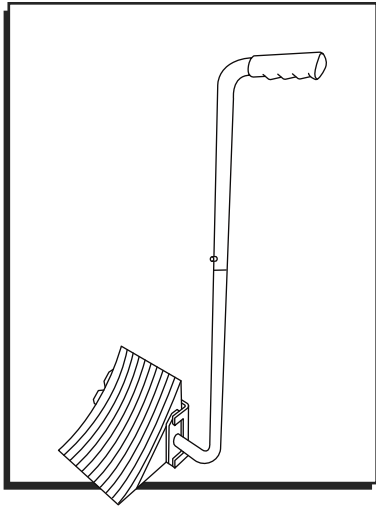

## PARTS

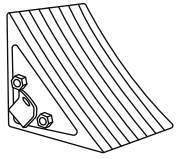

Wheel Chock x 1

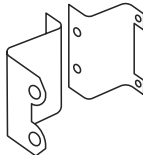

Bracket x 1

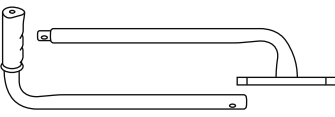

Handle x 1



Short Bolt x 2



Small Flat Washer x 2

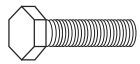

Small Bolt x 1



Small Locknut x 1



Large Flat Washer x 2

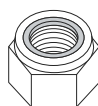

Large Locknut x 2

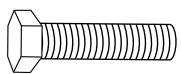

Large Bolt x 2

## ASSEMBLY

1. Fit handle pieces together and align holes. Use small bolt and locknut to secure. Tighten with 11 mm wrench. (See Figure 1)

 **NOTE:** Determine if chock will be configured left- or right-handed before completing step 2. Instructions show right-handed setup.

2. Attach handle to bracket using two short bolts and two small flat washers. Tighten with 13 mm wrench. (See Figure 2)

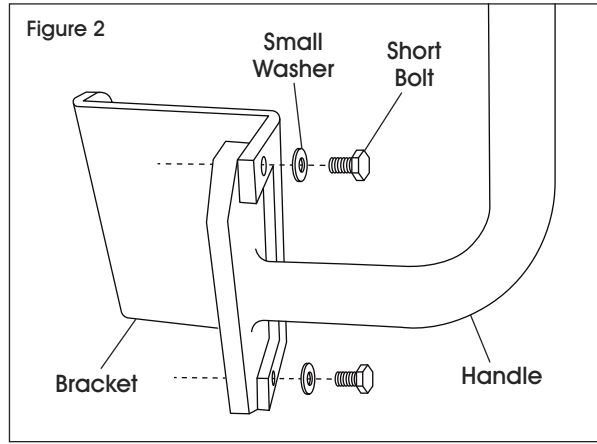
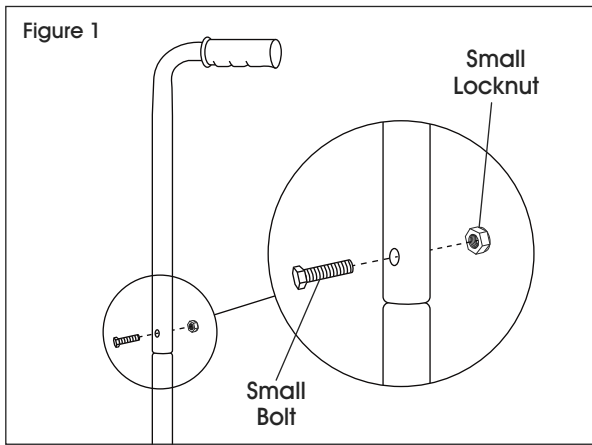

## ASSEMBLY CONTINUED

3. Place bracket around back of chock. Ensure wheel chock bolts fit inside outer bracket holes. (See Figures 3-4)

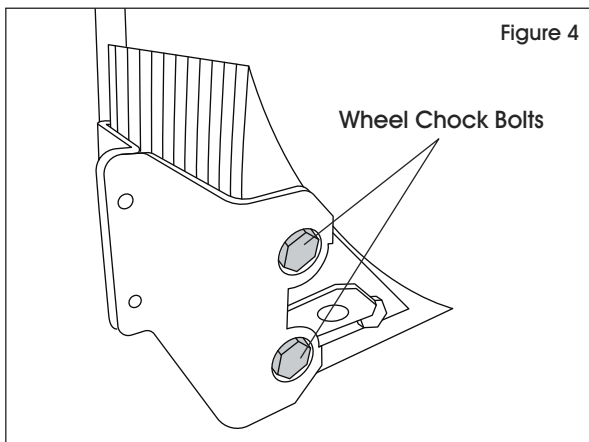
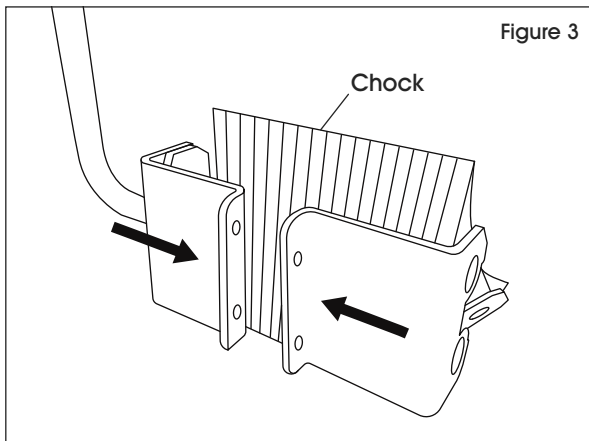

4. Secure bracket using two large bolts, two large flat washers and two large locknuts. Tighten with 14 mm wrench. (See Figure 5)

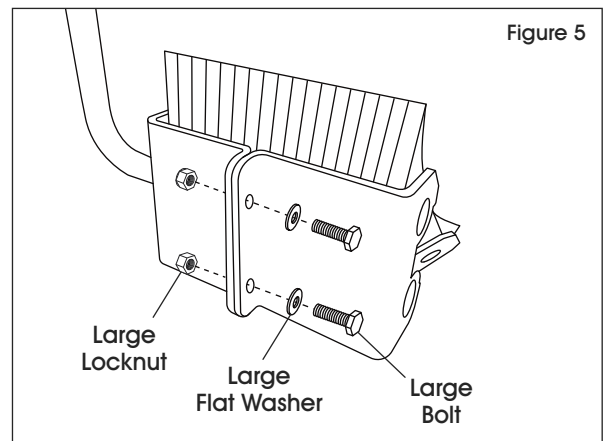

**ULINE** H-11622

# TOPE DE PLÁSTICO LAMINADO CON ASA LARGA PARA LLANTAS

800-295-5510  
uline.mx

## HERRAMIENTAS NECESARIAS



Llave Inglesa de 11 mm  
Llave Inglesa de 13 mm  
Llave Inglesa de 14 mm

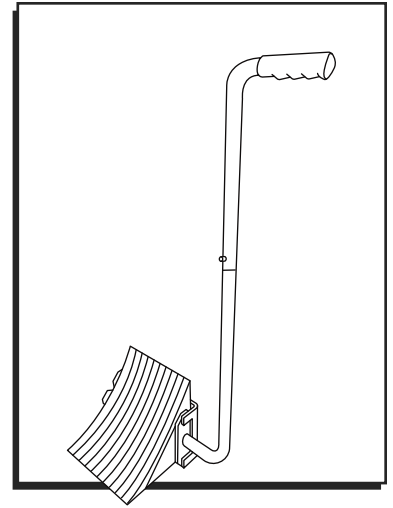

## PARTES

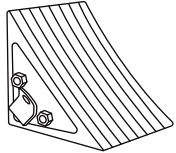

1 Tope para Llantas

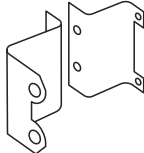

1 Soporte

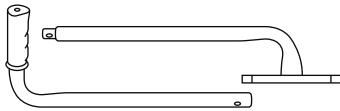

1 Asa



2 Pernos Cortos

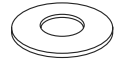

2 Rondanas Planas Chicas

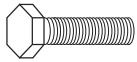

1 Perno Chico



1 Contratuerca Chica



2 Rondanas Planas Grandes

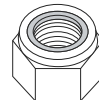

2 Contratuercas Grandes

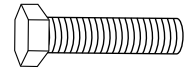

2 Pernos Grandes

## ENSAMBLE

1. Una las piezas del asa y alinee los orificios. Asegure con un perno chico y contratuerca. Apriete con una llave inglesa de 11 mm. (Vea Diagrama 1)

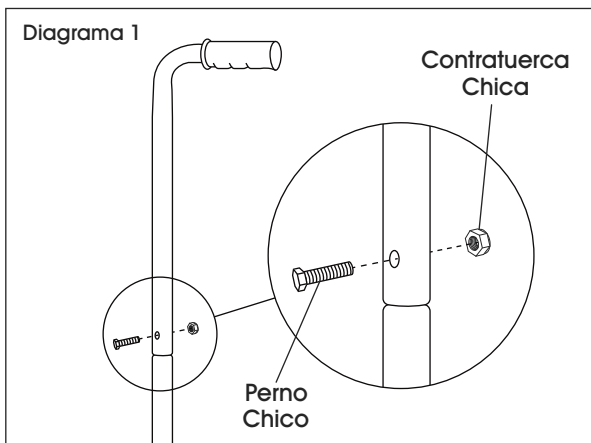

**NOTA:** Determine si el tope se configurará para zurdos o diestros antes de completar el paso 2. Las instrucciones muestran la configuración para diestros.

2. Fije el asa al soporte utilizando dos pernos cortos y dos rondanas planas chicas. Apriete con una llave inglesa de 13 mm. (Vea Diagrama 2)

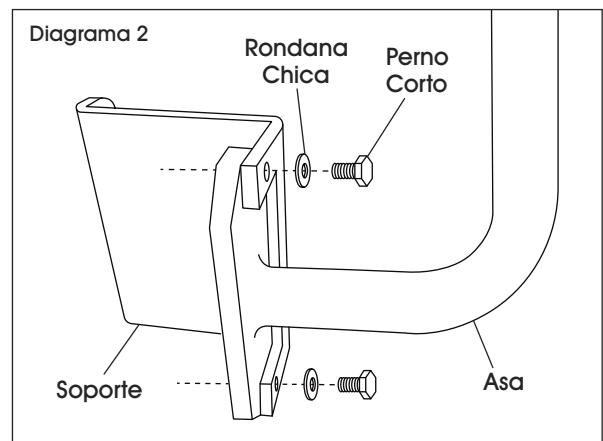

## CONTINUACIÓN DEL ENSAMBLE

3. Coloque el soporte alrededor de la parte posterior del tope. Asegúrese de que los pernos del tope para llantas se ajusten dentro de los orificios del soporte exterior. (Vea Diagramas 3-4)

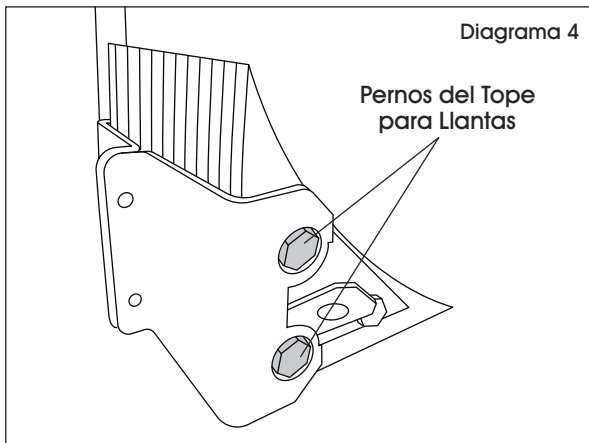
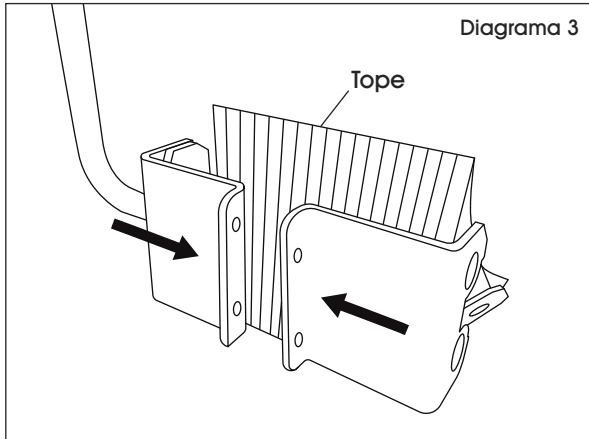

4. Asegure el soporte utilizando dos pernos grandes, dos rondanas planas grandes y dos contratuercas grandes. Apriete con una llave inglesa de 14 mm. (Vea Diagrama 5)

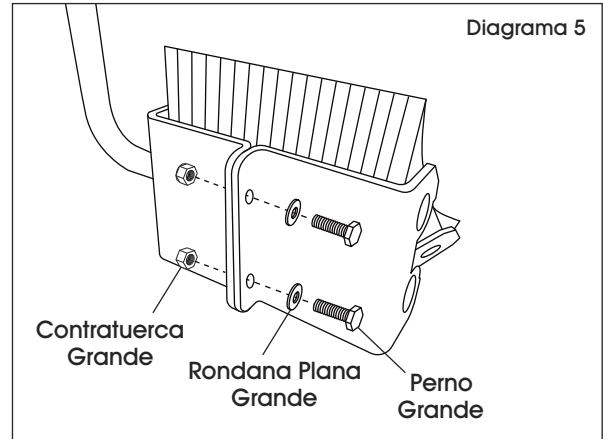

**CALE DE ROUE STRATIFIÉE  
AVEC LONGUE POIGNÉE****OUTILS REQUIS**

Clé de 11 mm  
Clé de 13 mm  
Clé de 14 mm

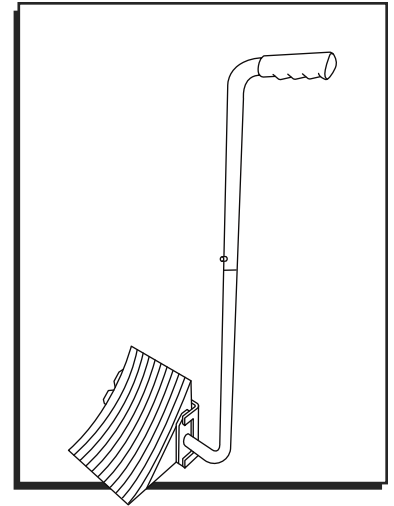
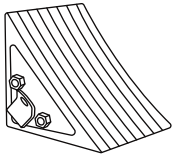
**PIÈCES**

Cale de roue x 1

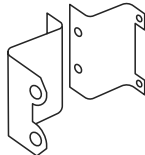

Support x 1

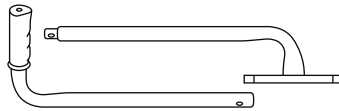

Poignée x 1



Boulon court x 2

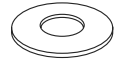

Petite rondelle plate x 2

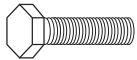

Petit boulon x 1

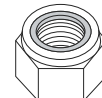
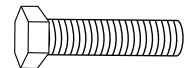

Petit écrou freiné x 1

Grande rondelle  
plate x 2Grand écrou  
freiné x 2

Grand boulon x 2

**MONTAGE**

1. Emboîtez les pièces de la poignée et alignez les trous. Fixez le tout avec un petit boulon et un petit écrou freiné. Serrez avec la clé de 11 mm. (Voir Figure 1)

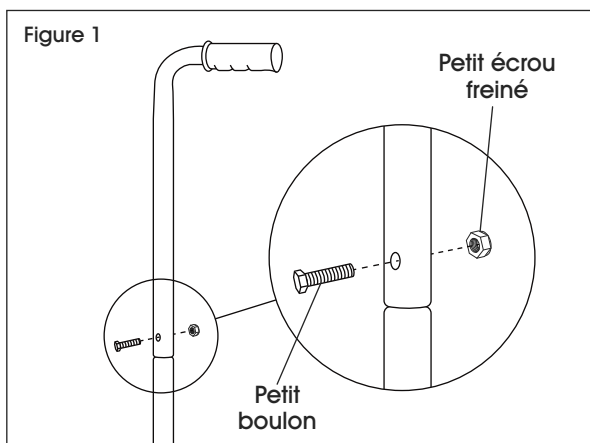

**REMARQUE :** Déterminez si la cale sera configurée pour gaucher ou droitier avant de compléter l'étape 2. Les instructions ci-dessous montrent la configuration pour droitier.

2. Fixez la poignée au support à l'aide de deux boulons courts et deux petites rondelles plates. Serrez avec la clé de 13 mm. (Voir Figure 2)

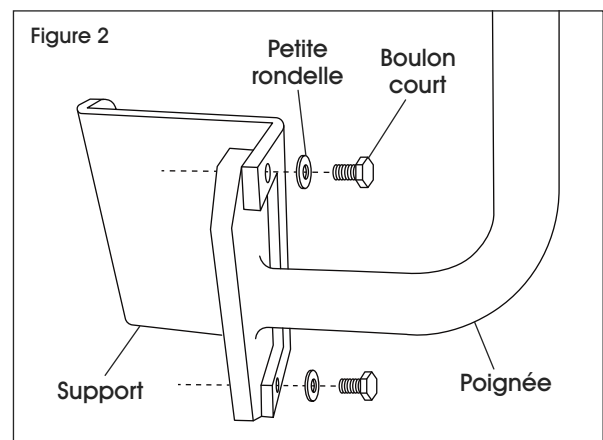

## MONTAGE SUITE

3. Placez le support à l'arrière de la cale. Assurez-vous que les boulons de la cale de roue s'insèrent dans les trous extérieurs du support. (Voir Figures 3 et 4)

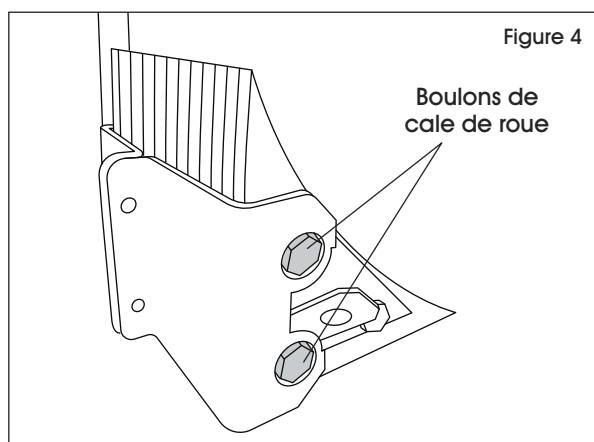
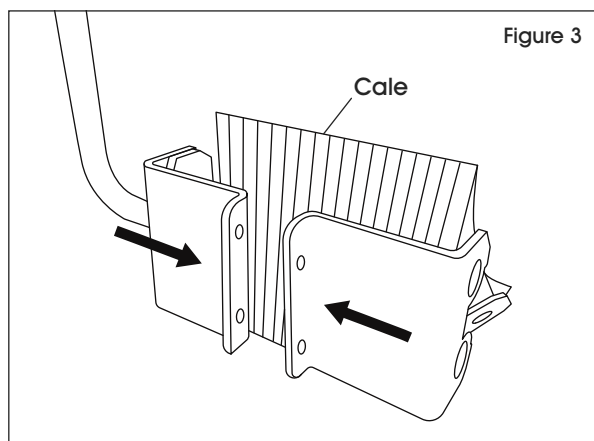

4. Fixez le support avec deux grands boulons, deux grandes rondelles plates et deux grands écrous freinés. Serrez avec la clé de 14 mm. (Voir Figure 5)

