

ULINE H-11627, H-11628 LIVE ANIMAL TRAP

1-800-295-5510
uline.com

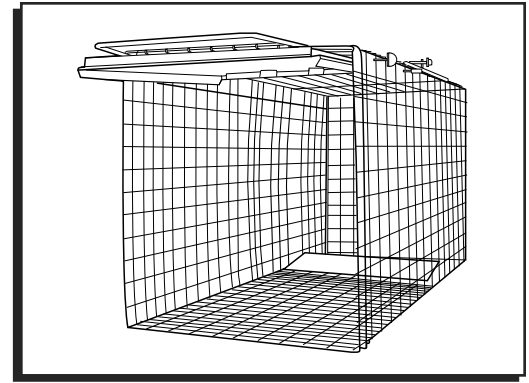

OPERATION

SETTING

1. Grab the lever from the front. (See Figure 1)

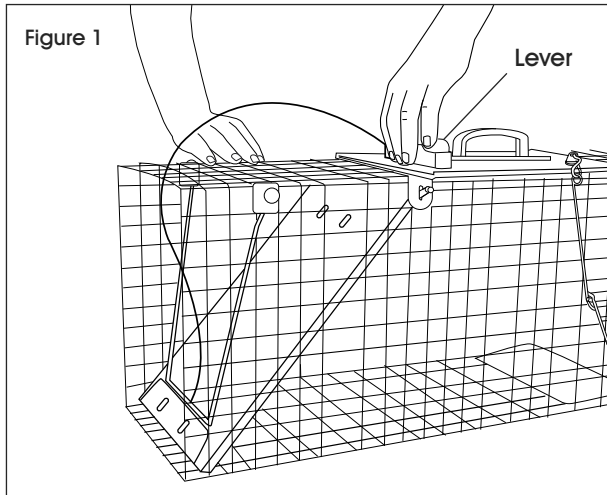

2. Pull lever back to lift door open. (See Figure 2)

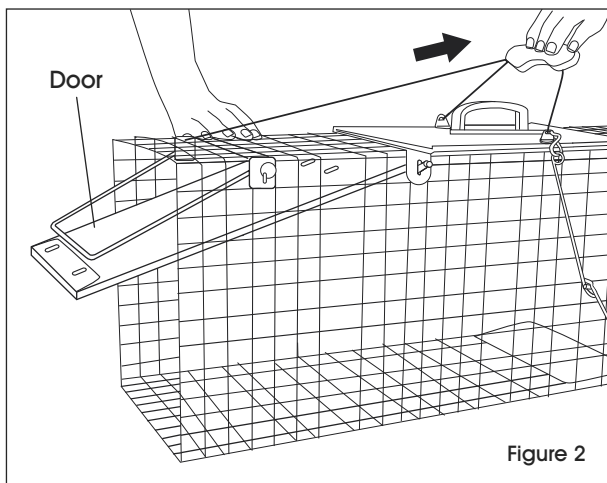

3. Door will lock into place. (See Figure 3)

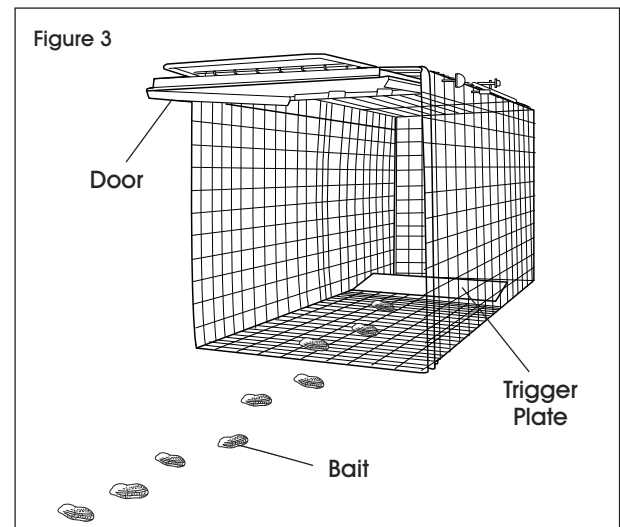

TIPS FOR BAITING

- Select a bait that is attractive to the animal.
- Wear gloves.
- Carefully position bait 2-3" from the back of the trap.

STOP IMPORTANT! Do not place bait on the trigger plate. (See Figure 3)

- Place bait in ways that force animals to interact with it.
- Create a trail of bait from the outside of trap. (See Figure 3)
- Introduce trap by baiting and propping the door open to help animals get comfortable.

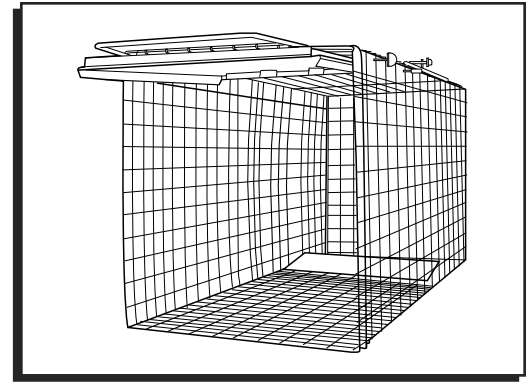

FUNCIONAMIENTO

COLOCACIÓN

1. Sujete la palanca por el frente. (Vea Diagrama 1)

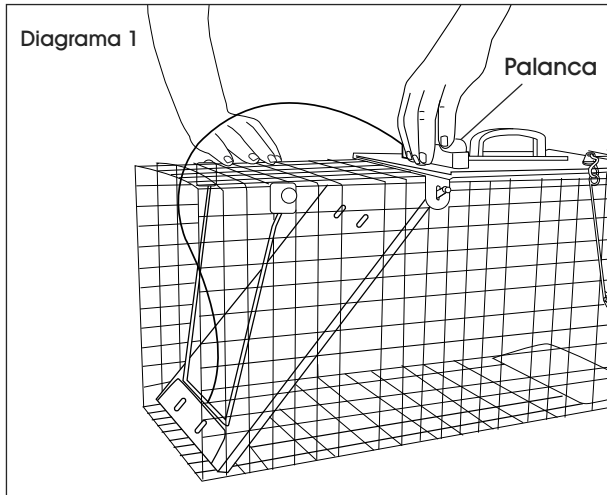

2. Jale la palanca hacia atrás para abrir la puerta. (Vea Diagrama 2)

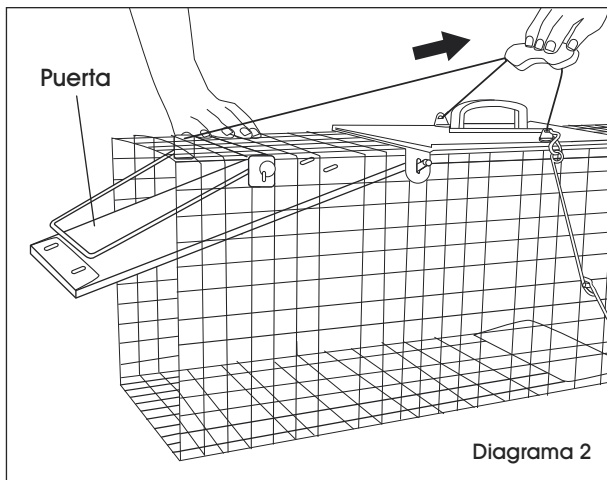

3. La puerta se fijará en su lugar. (Vea Diagrama 3)

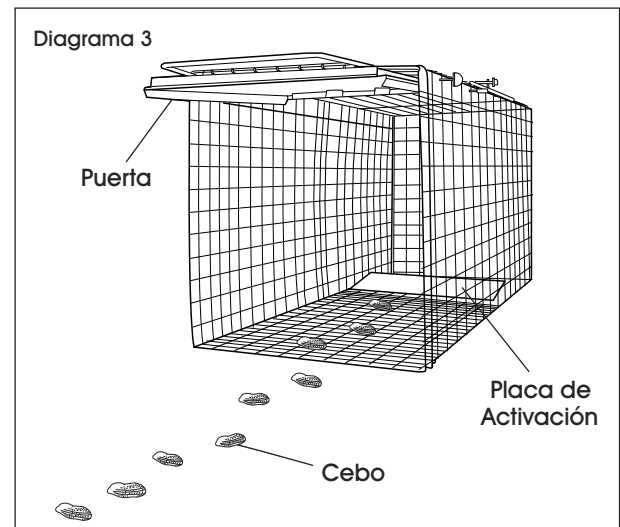

CONSEJOS PARA EL CEBO

- Elija un cebo atractivo para el animal.
- Utilice guantes.
- Coloque cuidadosamente el cebo a 5-7 cm (2-3") de la parte posterior de la trampa.

ALTO ¡IMPORTANTE! No coloque el cebo en la placa de activación. (Vea Diagrama 3)

- Coloque el cebo de forma que obligue la interacción con el animal.
- Forme un camino de cebo desde el exterior de la trampa. (Vea Diagrama 3)
- Coloque la trampa con el cebo adecuado y mantenga la puerta abierta para ayudar a que los animales se sientan en confianza.

ULINE H-11627, H-11628

PIÈGE POUR ANIMAUX VIVANTS

1 800 295-5510
uline.ca

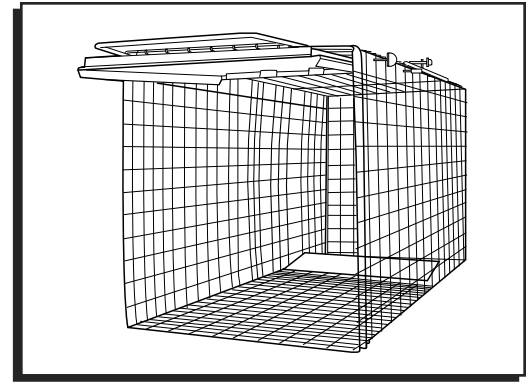

FONCTIONNEMENT

RÉGLAGE

1. Saisissez le levier par l'avant. (Voir Figure 1)

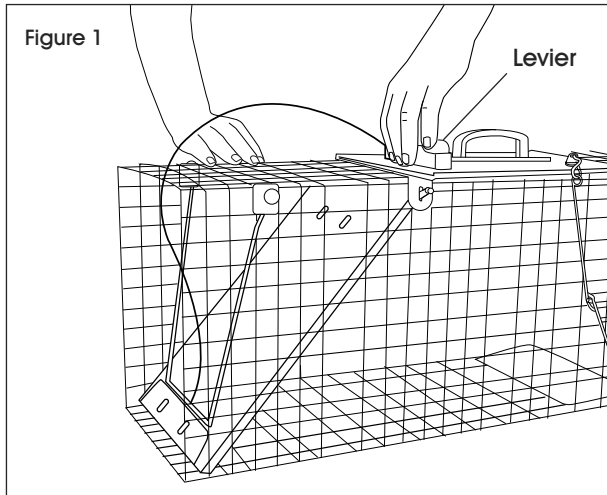

2. Tirez le levier vers l'arrière pour ouvrir la porte. (Voir Figure 2)

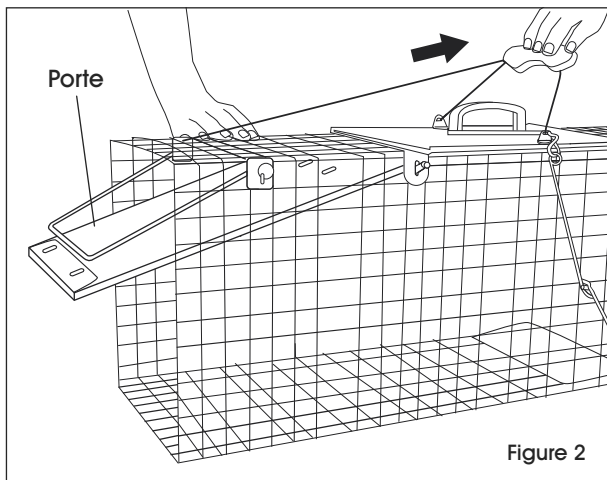

3. La porte se bloque en place. (Voir Figure 3)

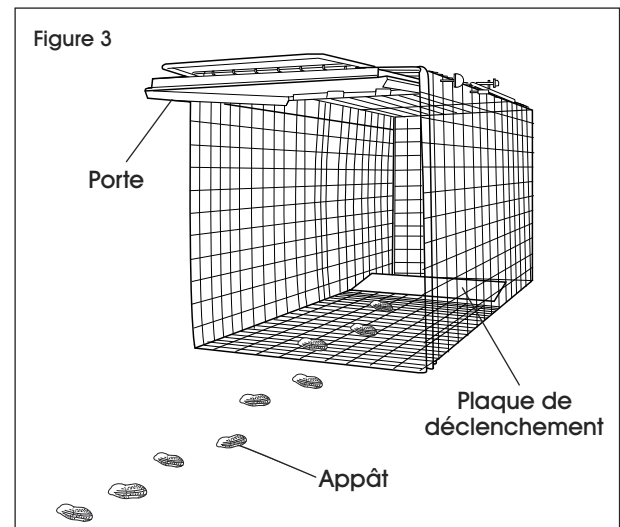

CONSEILS POUR L'APPÂTAGE

- Choisissez des appâts susceptibles d'attirer l'animal.
- Portez des gants.
- Positionnez soigneusement les appâts de 5 à 7 cm (2 à 3 po) du fond du piège.



IMPORTANT! Ne placez pas d'appâts sur la plaque de déclenchement. (Voir Figure 3)

- Placez les appâts de manière à forcer les animaux à interagir.
- Formez une ligne d'appâts à partir de l'extérieur du piège. (Voir Figure 3)
- Introduisez le piège en utilisant des appâts et en laissant la porte ouverte pour que les animaux se sentent à l'aise.