

ULINE H-11732, H-11733

METRO COLLECTION – RECEPTION DESK

1-800-295-5510
 uline.com

TOOLS NEEDED

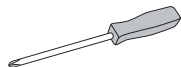

Phillips
 Screwdriver



4 mm Hex Wrench
 (included)



Two Person Assembly
 Recommended

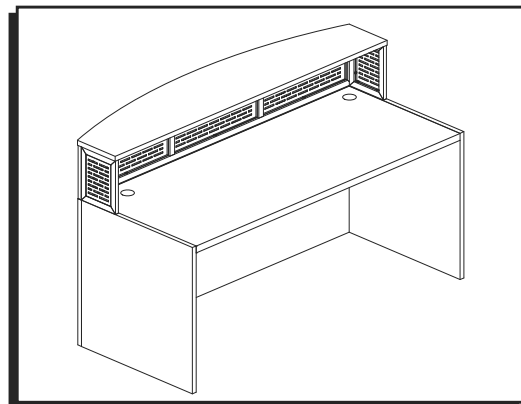

PARTS

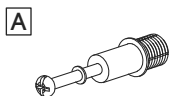

Cam Lock Pin x 16



Cam Lock x 16

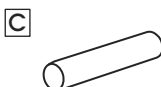

Dowel x 16



Cam Lock Cover x 16

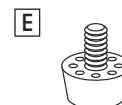

Adjustable Glide x 8

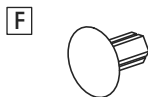

Leg Cap x 4



Grommet x 2

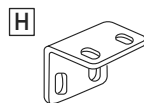

Metal Bracket x 6

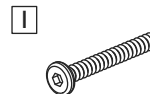

M6 x 45 mm Bolt x 18

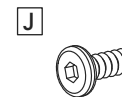

M6 x 15 mm Bolt x 24

DESK ASSEMBLY COMPONENTS

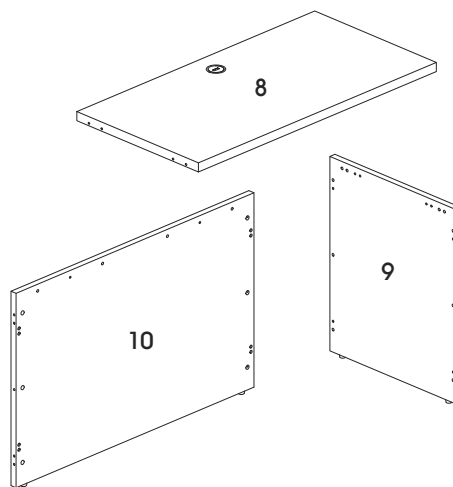
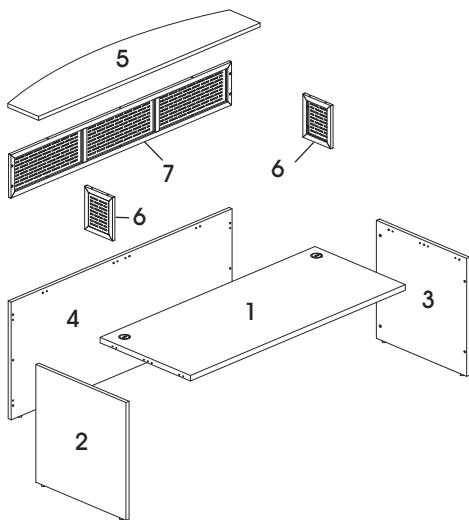

DESK PARTS

#	DESCRIPTION	QTY.
1	Desktop	1
2	Left Side Panel	1
3	Right Side Panel	1
4	Modesty Panel	1
5	Countertop Panel	1
6	Privacy Hutch Side Panel	2
7	Privacy Hutch Front Panel	1

OPTIONAL L-DESK RETURN PARTS

#	DESCRIPTION	QTY.
8	Return Desktop	1
9	Return Side Panel	1
10	Return Modesty Panel	1

ASSEMBLY



NOTE: Check that all parts are included.



NOTE: Assemble on smooth, non-marring surface to avoid scratching. Use Allen wrench to tighten bolts. Use Phillips screwdriver to tighten cam lock pins and cam locks.



IMPORTANT! Ensure arrow is pointing toward edge of panel before inserting into panel's hole. Turn cam lock 1/4 to the right to lock.

IMPORTANT! FUNCTION OF CAM LOCK

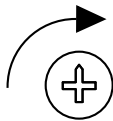

**1/4 RIGHT TURN
FOR LOCKING**

Ensure the arrow is pointing toward edge of panel before inserting into the panel's hole.



IMPORTANT! Cam lock pins must be tightened once inserted into panel. To tighten, grasp lower part of cam lock pin and tighten using a Phillips screwdriver.

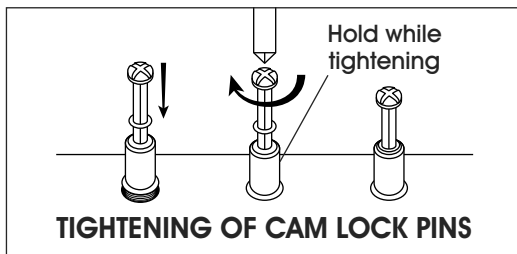

1. Install three cam lock pins (A), four dowels (C) and two floor glides (E) into each side panel (2, 3). (See Figure 1)

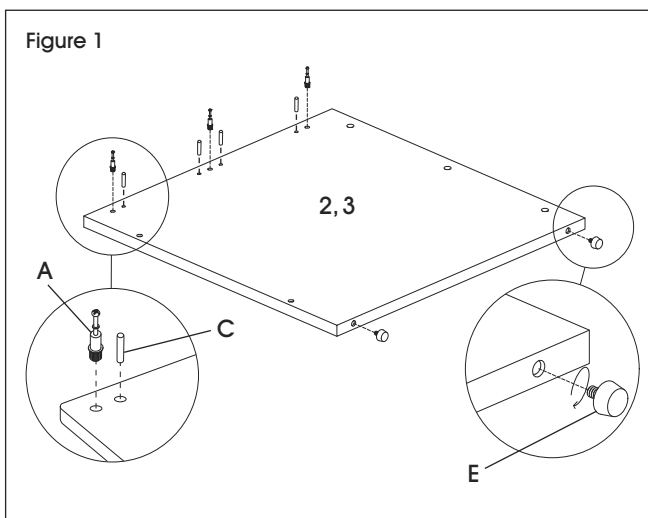

2. Insert six cam locks (B) into desktop (1). Fit side panels (2, 3) together with desktop (1) and use a Phillips screwdriver to turn each cam lock clockwise until it locks. (See Figure 2)



NOTE: Cam lock covers (D) can be applied once cam locks are tightened for finished look.

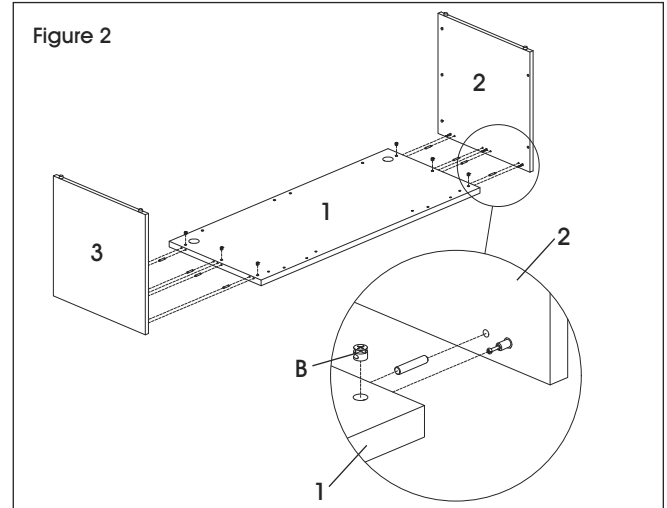

3. Install 10 cam lock pins (A), eight dowels (D) and four floor glides (E) in the modesty panel (4). (See Figure 3)

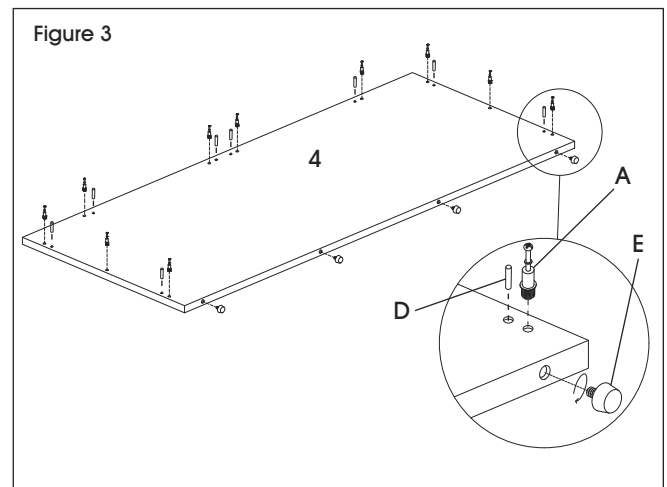

ASSEMBLY CONTINUED

- Install 10 cam locks (B) in the desktop (1) and side panels (2, 3). Attach the modesty panel (4) to the assembled desktop and side panels. (See Figure 4)

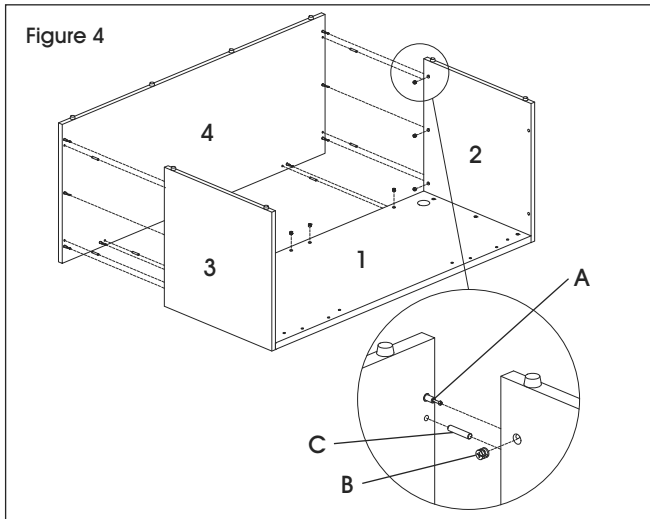

- Place countertop panel (5) upside down with holes facing up. With second person, position privacy hutch on top of the countertop panel and use seven M6 x 45 mm bolts (I) to attach. (See Figure 7)

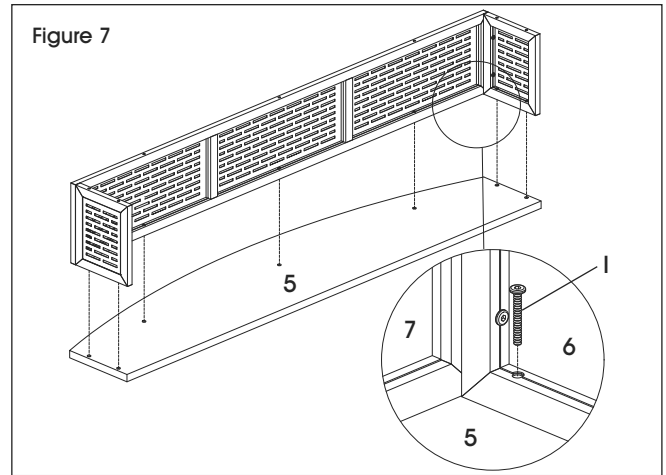

- Install six metal brackets (H) to desk shell using 24 M6 x 15 mm bolts (J). With second person, place assembled desk shell upright. (See Figure 5)

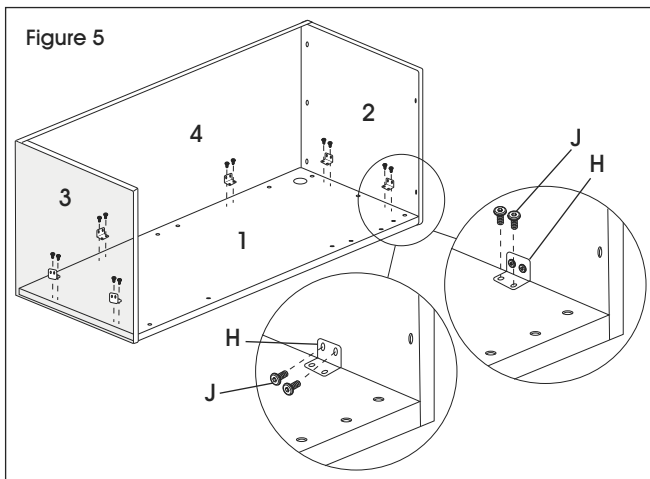

- With second person, turn assembled transaction counter upright. Use seven M6 x 45 mm bolts (I) to secure to the assembled desk shell. Apply leg caps (F) for finished look. (See Figure 8)

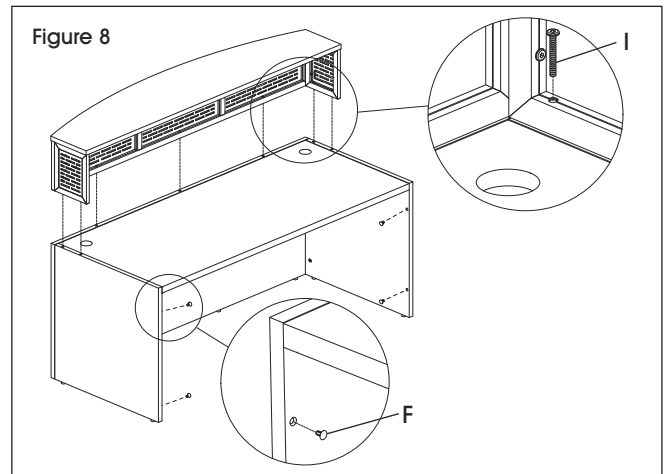

- Attach privacy hutch side panels (6) to front panel (7) using four M6 x 45 mm bolts (I). (See Figure 6)

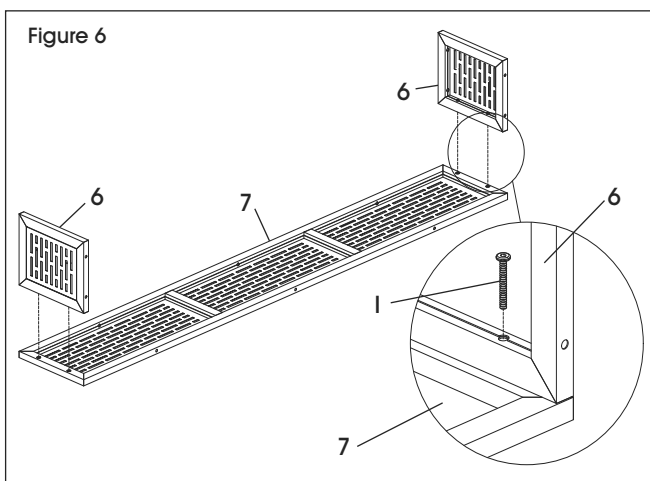

- Insert grommets (G) into desktop. (See Figure 9)

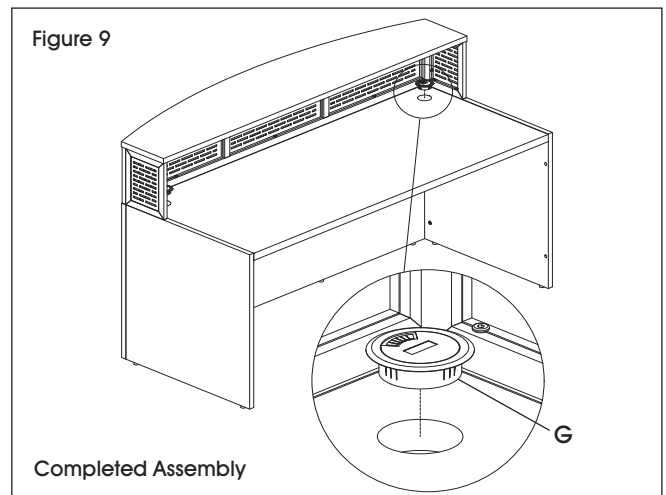

L-DESK RETURN ASSEMBLY PARTS

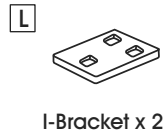
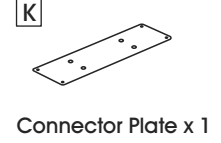
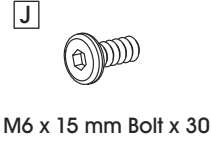
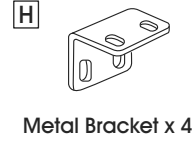
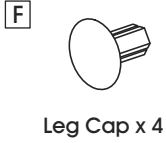
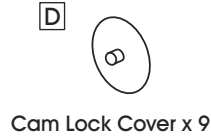
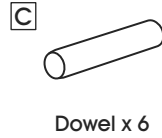
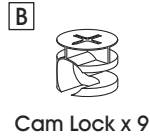

L-DESK ASSEMBLY



NOTE: Determine whether the L-desk will be set up right-hand or left-hand configuration. This will impact how the return is assembled. Assembly of a right-hand L-desk is shown in the following figures.

1. Install four cam lock pins (A), two dowels (C) and two floor glides (E) into return modesty panel (10). (See Figure 10)

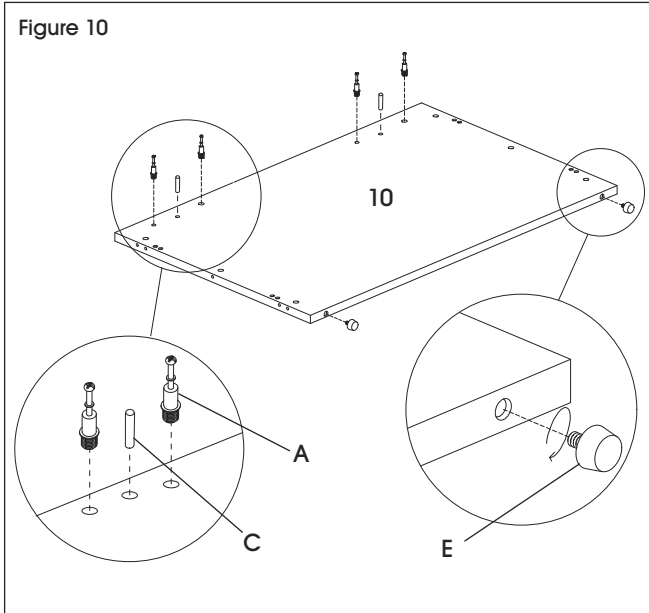

2. Install four cam locks (B) in return desktop (8). Attach return desktop (8) to return modesty panel (10). (See Figure 11)

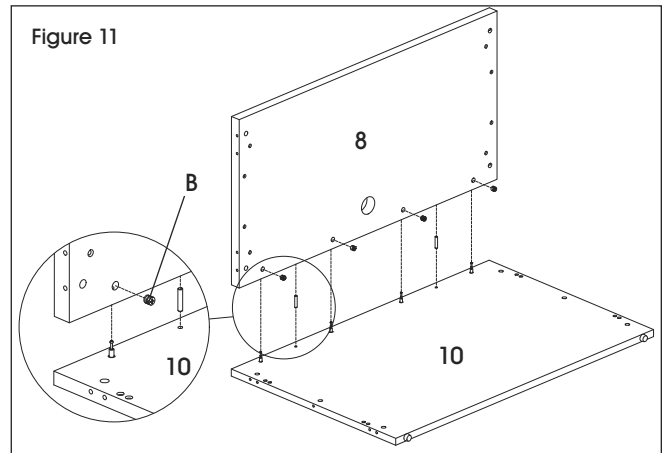

3. Insert five cam lock pins (A), four dowels (C) and two adjustable glides (E) into return side panel (9). (See Figure 12)

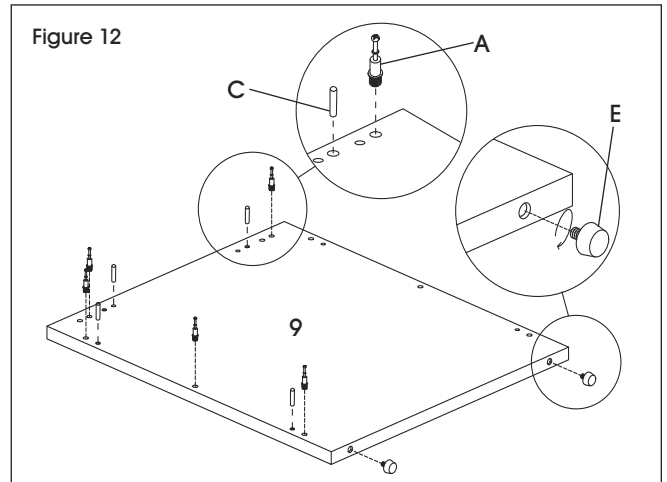

L-DESK ASSEMBLY CONTINUED

4. Insert five cam locks (B) to return desktop (8) and return modesty panel (10). Attach return side panel to return modesty panel and return desktop. Turn each cam lock (B) clockwise until it locks. (See Figure 13)

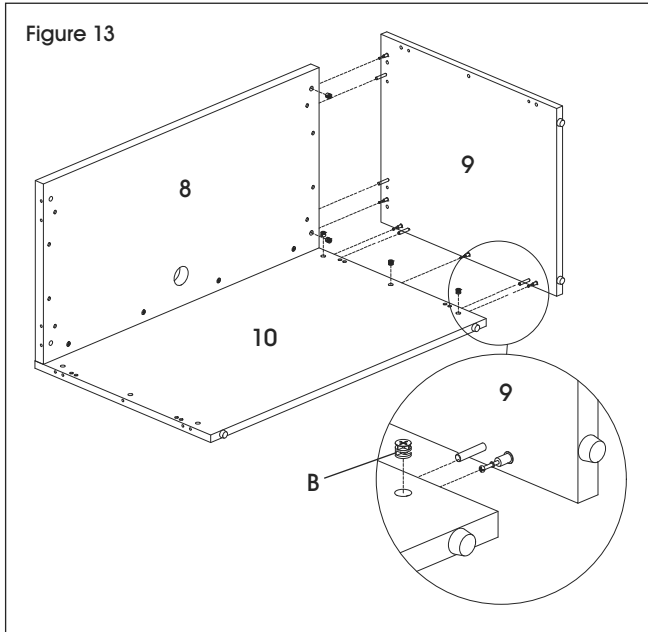

5. Install four metal brackets (H) to the return shell (8, 9, 10) using 16 M6 x 15 mm bolts (J). (See Figure 14)

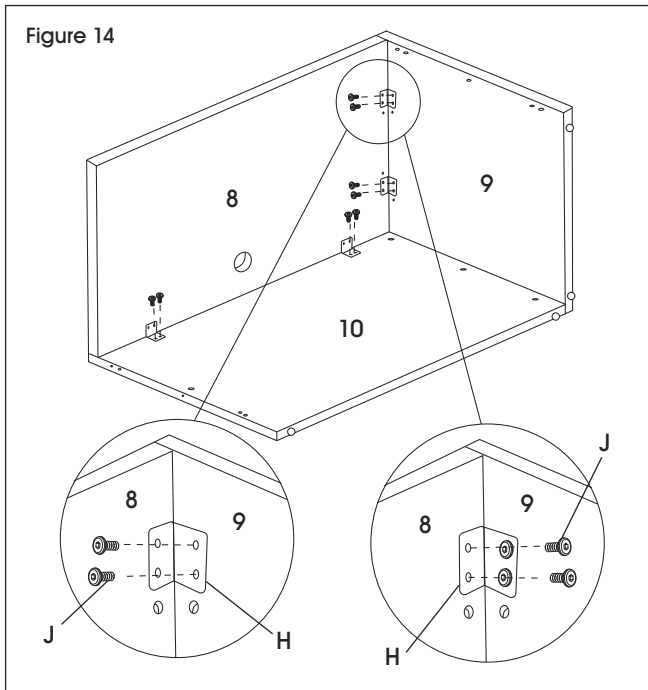

6. Install connector plate (K) to return desktop (8) using four M6 x 15 mm bolts (J). (See Figure 15)

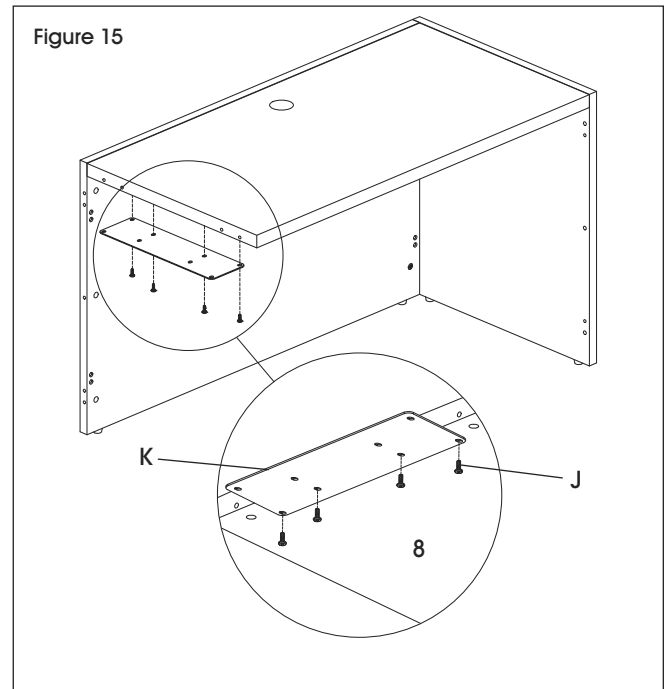

7. Install two I-Brackets (L) to return modesty panel (10) using four M6 x 15 mm bolts (J). (See Figure 16)

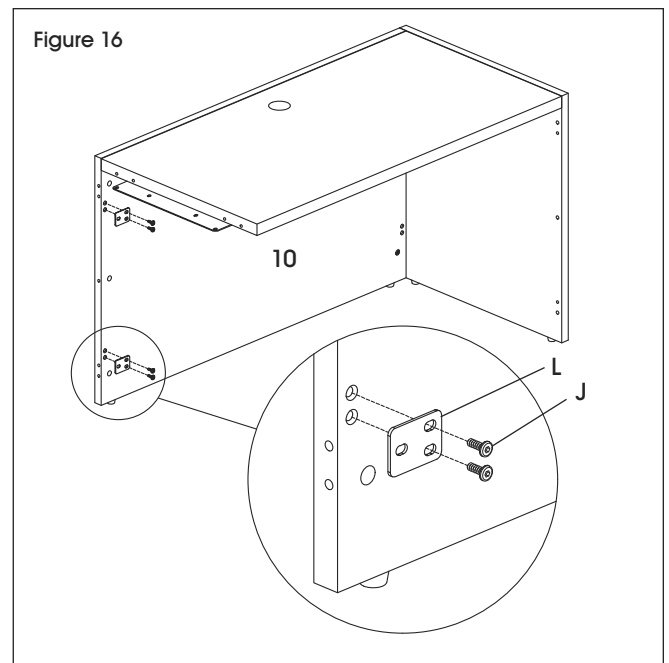

L-DESK ASSEMBLY CONTINUED

8. Cover exposed holes using hole caps (M, N and O), and leg caps (F). Insert grommet (G) into return top. (See Figure 17)

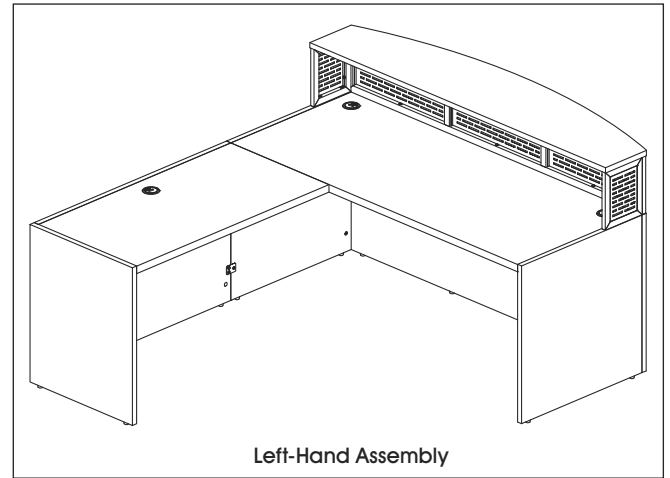
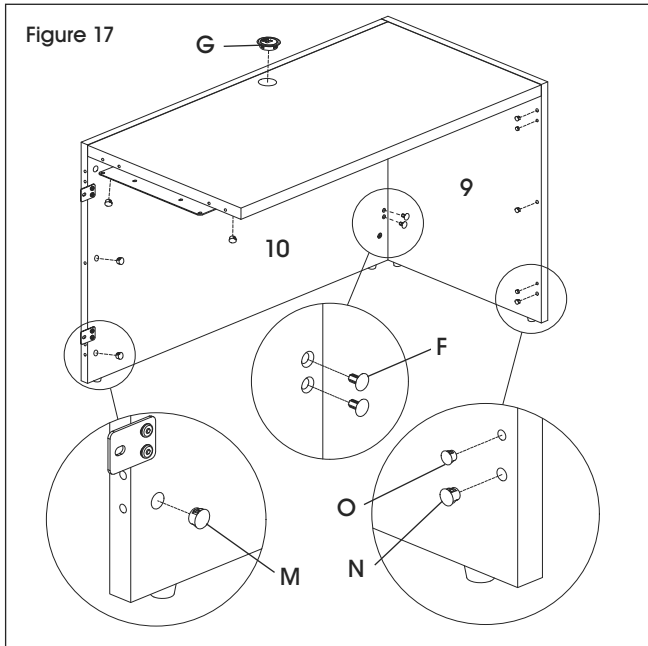

9. With second person, position L-Desk return next to assembled desk. Attach connector plate (K) to desktop (I) with four M6 x 15 mm bolts (J). Attach I-Brackets (L) to desk side panel with two M6 x 15 mm bolts (J). (See Figure 18)

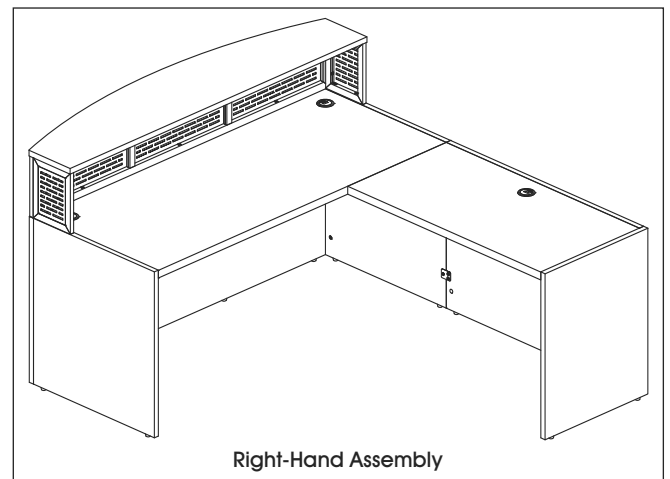
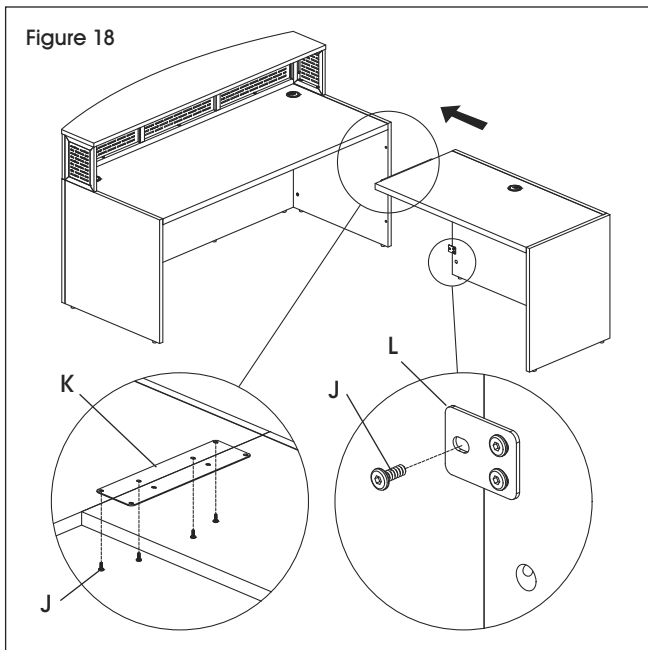

ULINE

1-800-295-5510
uline.com

ULINE H-11732, H-11733

COLECCIÓN METROPOLITANA – ESCRITORIO DE RECEPCIÓN

800-295-5510
uline.mx

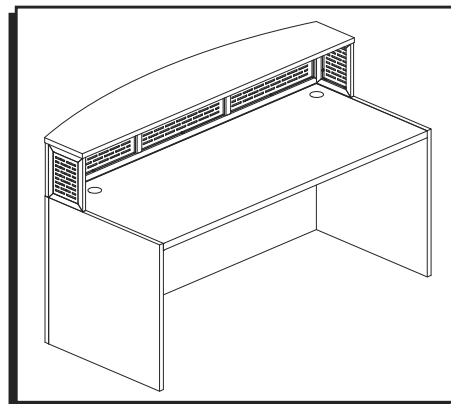

HERRAMIENTAS NECESARIAS

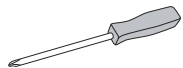

Desarmador
de Cruz



Llave Hexagonal
de 4 mm (incluida)



Se Recomienda Armar
Entre Dos Personas

PARTES

A

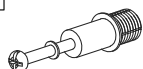

16 Pasadores para
Tuercas Minifix

B



16 Tuercas Minifix

C



16 Taquetes

D



16 Cubiertas para
Tuercas Minifix

E



8 Tapas Niveladoras

F



4 Tapas para Pata

G



2 Ojales

H

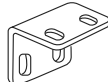

6 Soportes de Metal

I



18 Pernos M6 x 45 mm

J



24 Pernos M6 x 15 mm

COMPONENTES DE ENSAMBLE DEL ESCRITORIO

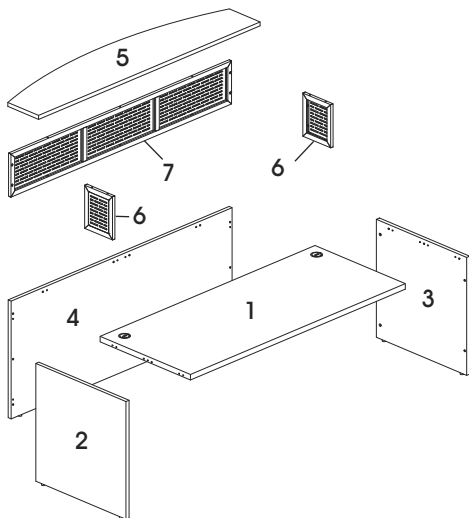

PARTES DEL ESCRITORIO

#	DESCRIPCIÓN	CANT.
1	Cubierta	1
2	Panel Lateral Izquierdo	1
3	Panel Lateral Derecho	1
4	Recato	1
5	Cubierta del Mostrador	1
6	Panel Lateral para Mostrador Alto de Privacidad	2
7	Panel Frontal para Mostrador Alto de Privacidad	1

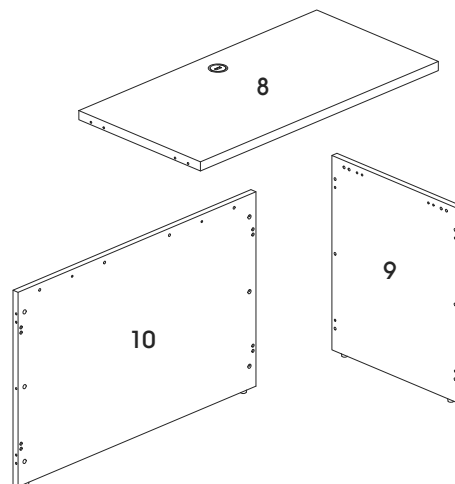



PARTES PARA RETORNO OPCIONAL DE ESCRITORIO EN L

#	DESCRIPCIÓN	CANT.
8	Cubierta del Retorno	1
9	Panel Lateral del Retorno	1
10	Recato del Retorno	1

ENSAMBLE

 **NOTA:** Revise que todas las partes estén incluidas.

 **NOTA:** Ensamble sobre una superficie lisa que no deje marcas para evitar rayones. Utilice la llave Allen para apretar los pernos. Use un desarmador de cruz para apretar los pasadores para tuercas minifix y las tuercas minifix.

 **¡IMPORTANTE!** Asegúrese de que la flecha apunte hacia el borde del panel antes de introducirla en el orificio del panel. Gire la tuerca minifix 1/4 a la derecha para asegurarla.

¡IMPORTANTE! FUNCIÓN DE LA TUERCA MINIFIX



Asegúrese de que la flecha apunte hacia el borde del panel antes de insertarla en el orificio.

 **¡IMPORTANTE!** Los pasadores para tuercas minifix se deben apretar una vez se inserten en el panel. Para apretarlos, sostenga la parte inferior del pasador y apriete con el desarmador de cruz.

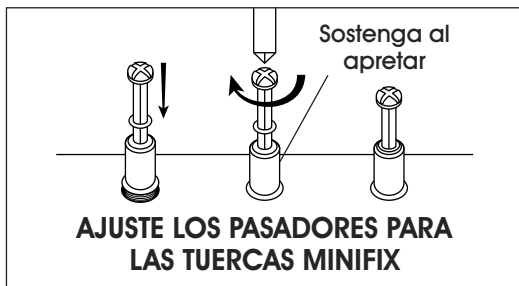

1. Instale tres pasadores para tuercas minifix (A), cuatro taquetes (C) y dos tapas niveladoras (E) en cada panel lateral (2, 3). (Vea Diagrama 1)

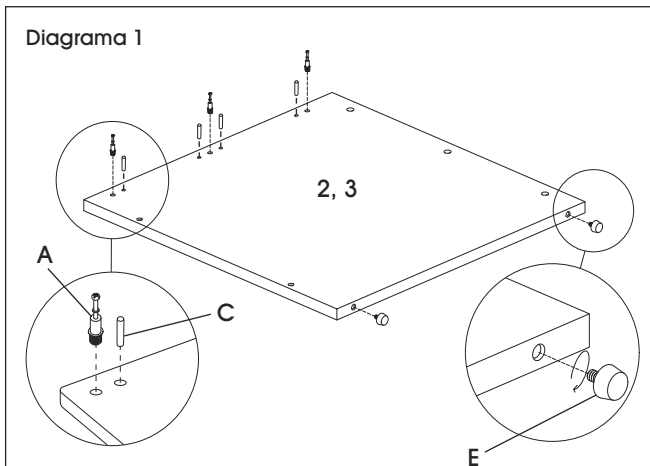

2. Inserte seis tuercas minifix (B) en la cubierta (1). Junte los paneles laterales (2, 3) con la cubierta (1) y utilice un desarmador de cruz para girar cada tuerca minifix en el sentido de las manecillas del reloj hasta que se bloqueen. (Vea Diagrama 2)

 **NOTA:** Puede colocar las cubiertas para tuercas minifix (D) una vez que las haya apretado para dar una apariencia terminada.

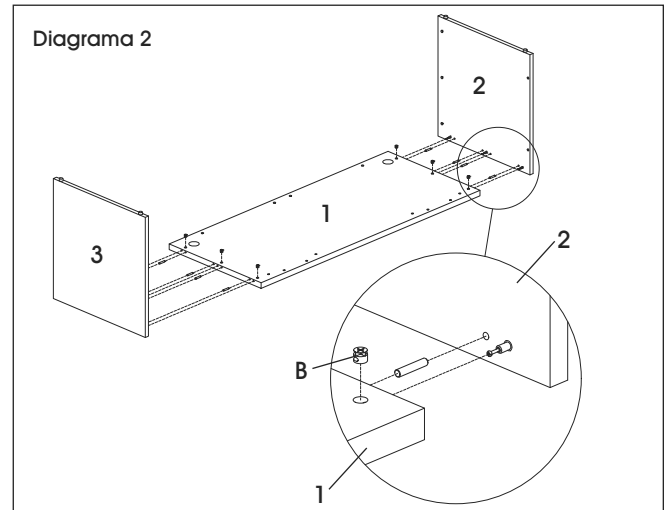

3. Instale 10 pasadores para tuercas minifix (A), ocho taquetes (D) y cuatro tapas niveladoras (E) en el recato (4). (Vea Diagrama 3)

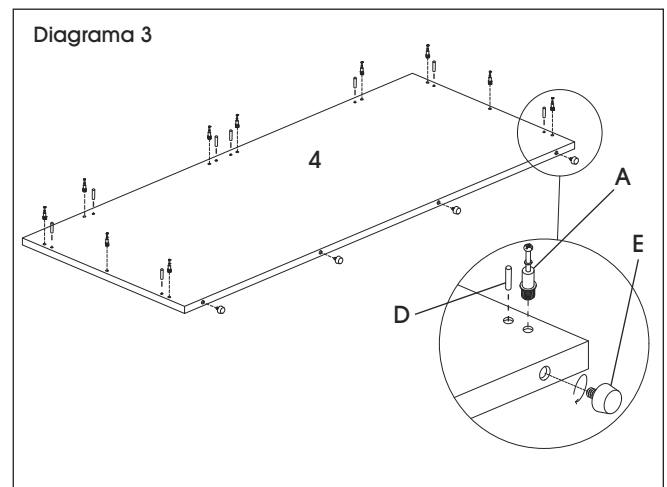

CONTINUACIÓN DE ENSAMBLE

4. Instale 10 tuercas minifix (B) en la cubierta (1) y los paneles laterales (2, 3). Fije el recato (4) al ensamble de la cubierta y los paneles laterales. (Vea Diagrama 4)

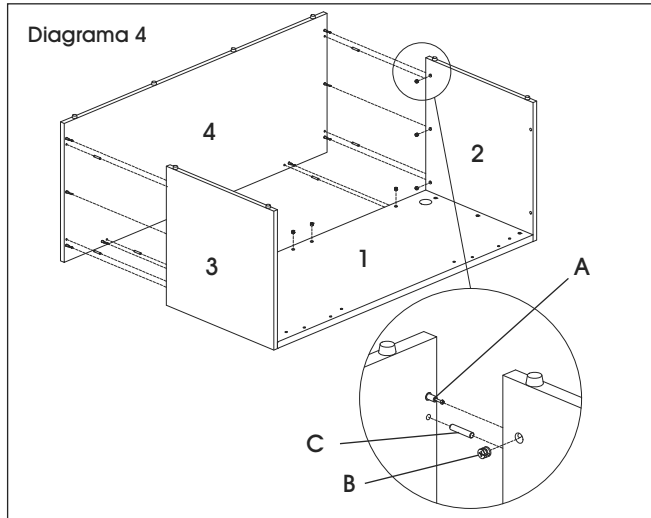

5. Instale seis soportes de metal (H) al armazón del escritorio usando los 24 pernos M6 x 15 mm (J). Con ayuda de una segunda persona, enderece el armazón del escritorio. (Vea Diagrama 5)

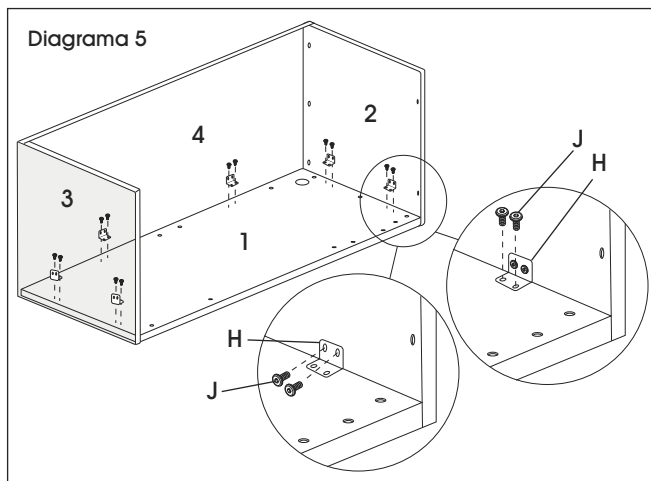

6. Instale los paneles laterales para mostrador alto de privacidad (6) al panel frontal (7) usando cuatro pernos M6 x 45 mm (I). (Vea Diagrama 6)

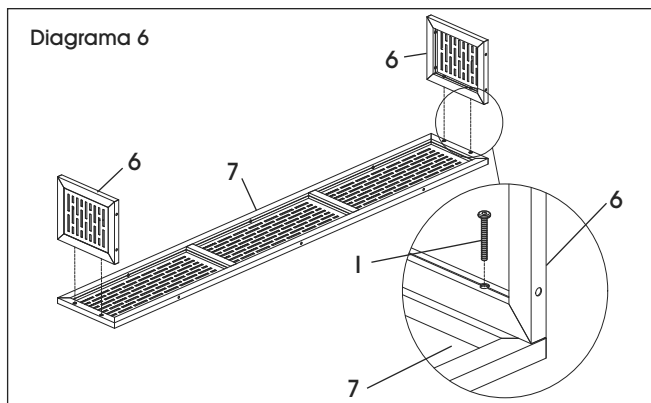

7. Coloque la cubierta del mostrador (5) boca abajo con los orificios hacia arriba. Con ayuda de una segunda persona, coloque el mostrador alto de privacidad sobre la cubierta del mostrador y use siete pernos M6 x 45 mm (I) para fijarlo. (Vea Diagrama 7)

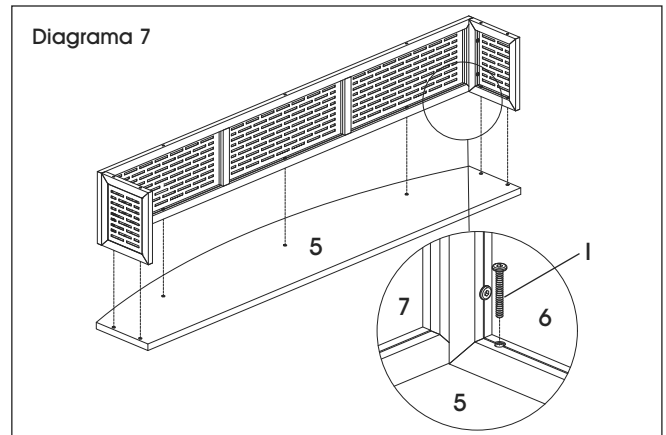

8. Con ayuda de una segunda persona, enderece el mostrador ensamblado. Utilice siete pernos M6 x 45 mm (I) para asegurar el mostrador a la cubierta del armazón del escritorio. Aplique las tapas de las patas (F) para una apariencia terminada. (Vea Diagrama 8)

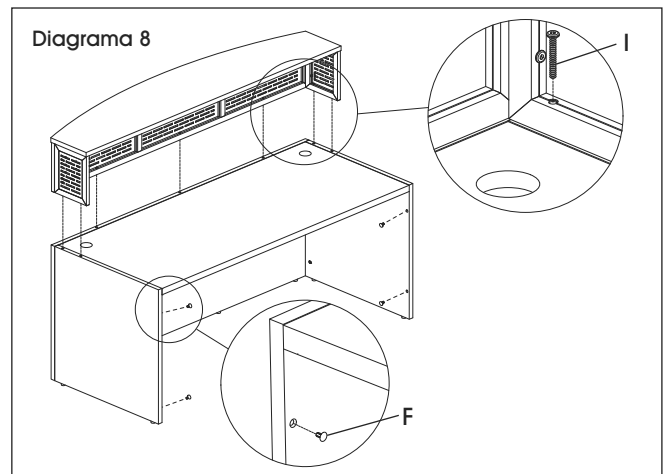

9. Inserte los ojales (G) en la cubierta del escritorio. (Vea Diagrama 9)

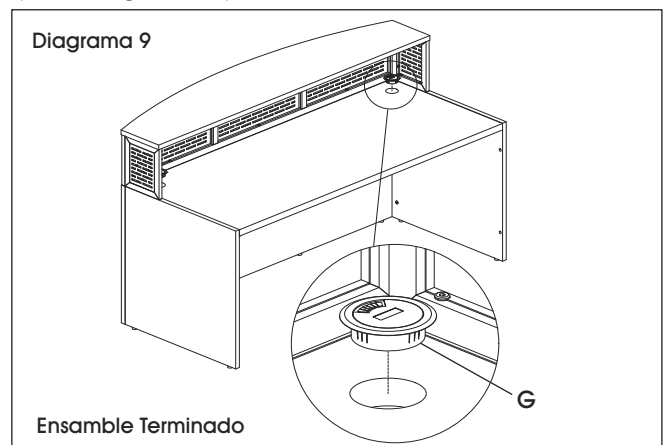

PARTS PARA EL ENSAMBLE DEL RETORNO DEL ESCRITORIO EN L

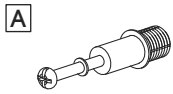

9 Pasadores para Tuercas Minifix



9 Tuercas Minifix

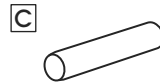

6 Taquetes



9 Cubiertas para Tuercas Minifix

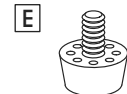

4 Tapas Niveladoras

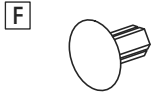

4 Tapas para Pata



1 Ojal

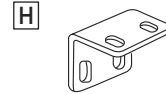

4 Soportes de Metal

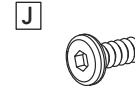

30 Pernos M6 x 15 mm

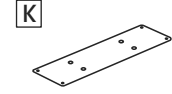

1 Placa Conectora

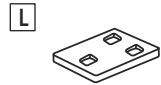

2 Soportes en L



5 Tapas para Orificio para Tuercas Minifix



3 Tapas para Orificio para Tuercas Minifix



2 Tapas para Orificio para Taquetes

ENSAMBLE DEL ESCRITORIO EN L

ALTO

NOTA: Determine si el escritorio L estará configurado para zurdos o diestros. Esto impactará el ensamble del retorno. Se muestra el ensamble de un escritorio en L para diestros en los siguientes diagramas.

1. Instale cuatro pasadores para tuercas minifix (A), dos taquetes (C) y dos tapas niveladoras (E) en el recato del retorno (10). (Vea Diagrama 10)

Diagrama 10

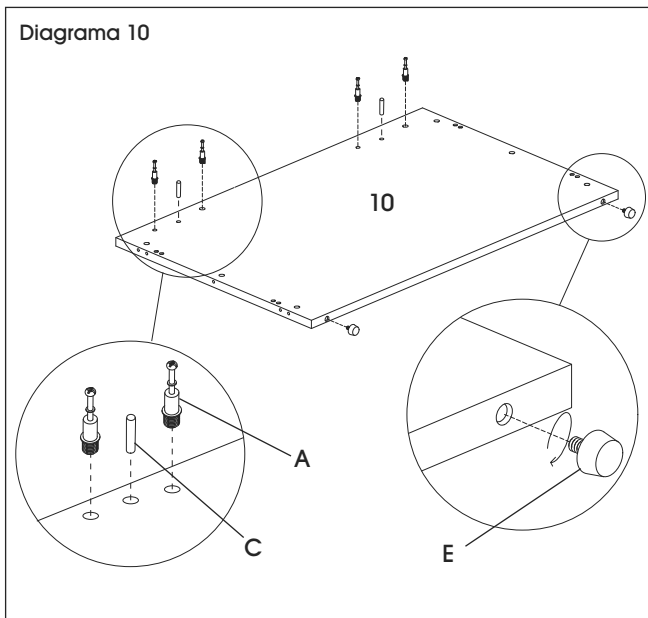

2. Instale cuatro tuercas minifix (B) en la cubierta del retorno (8). Fije la cubierta del retorno (8) al recato del retorno (10). (Vea Diagrama 11)

Diagrama 11

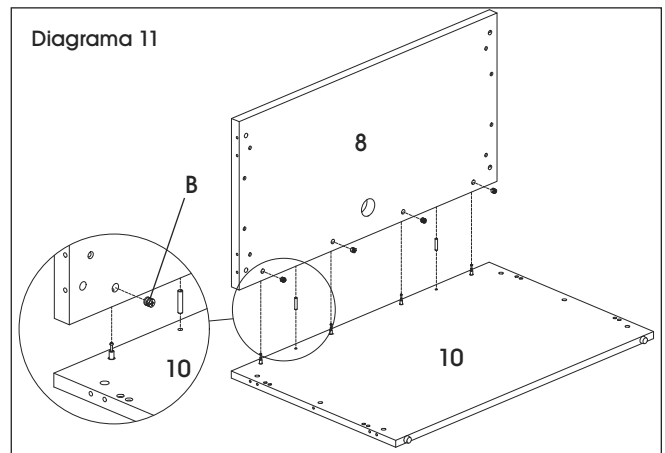

3. Instale cinco pasadores para tuercas minifix (A), cuatro taquetes (C) y dos tapas niveladoras (E) en cada panel lateral del retorno (9). (Vea Diagrama 12)

Diagrama 12

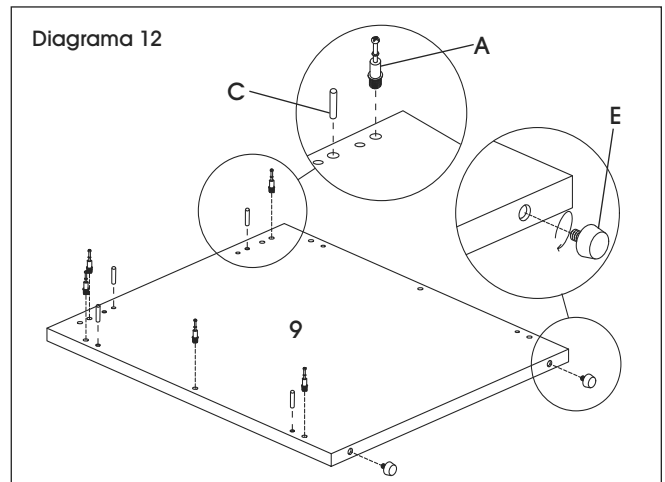

CONTINUACIÓN DEL ENSAMBLE DEL ESCRITORIO EN L

4. Inserte cinco tuercas minifix (B) en la cubierta del retorno (8) y el panel de retorno del recato (10). Fije el panel lateral del retorno al recato del retorno y la cubierta del retorno. Gire cada tuerca minifix (B) en el sentido de las manecillas del reloj hasta que se bloqueen. (Vea Diagrama 13)

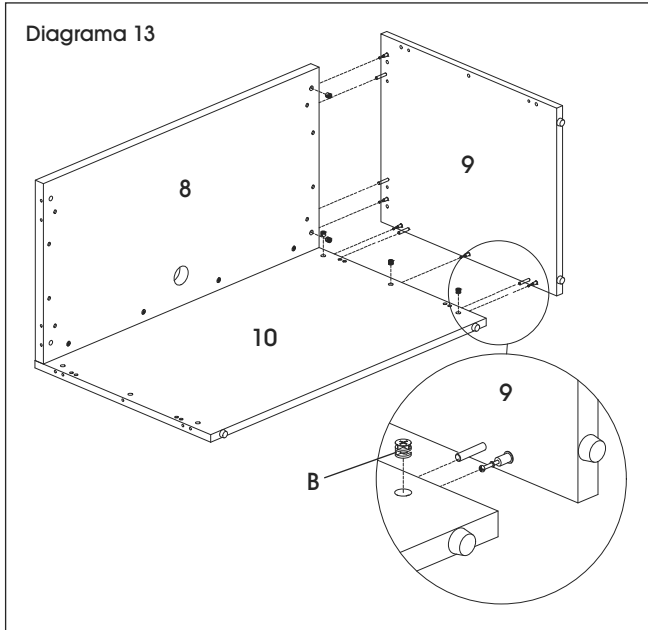

5. Instale cuatro soportes de metal (H) al armazón del retorno (8, 9, 10) usando 16 pernos M6 x 15 mm (J). (Vea Diagrama 14)

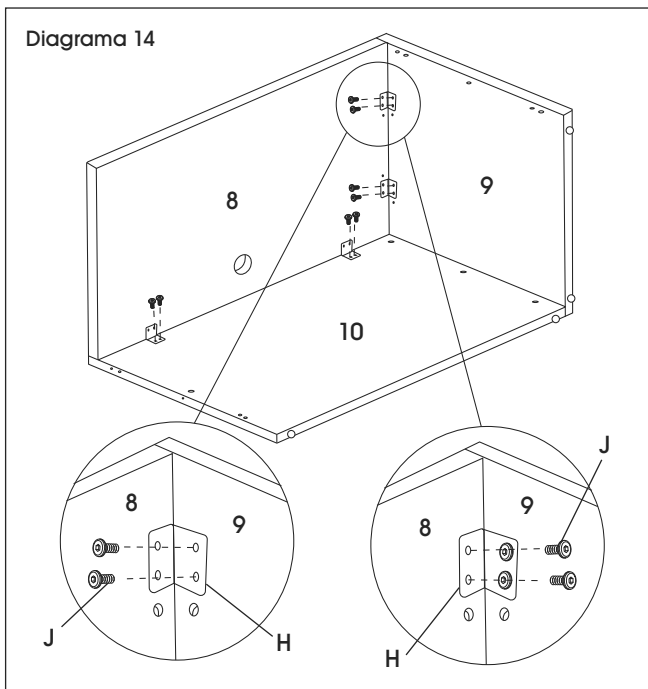

6. Instale la placa conectora (K) a la cubierta del retorno (8) con cuatro pernos M6 x 15 mm (J). (Vea Diagrama 15)

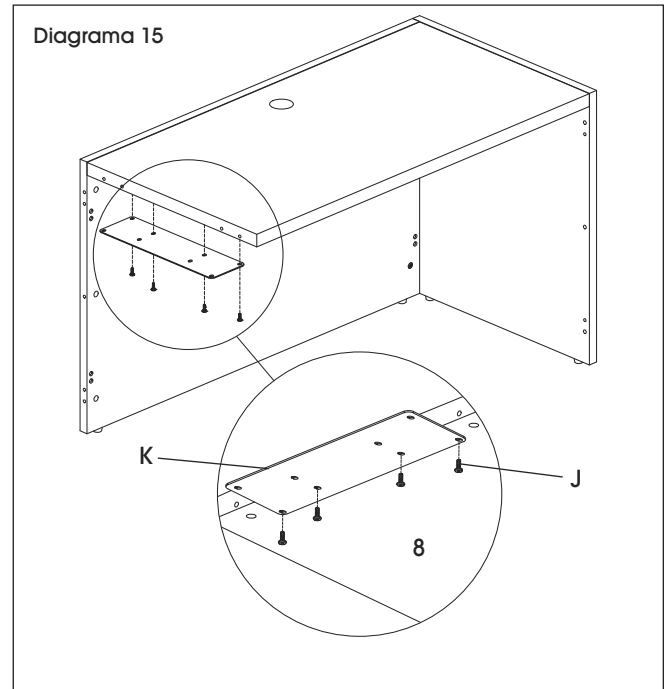

7. Instale dos Soportes en I (L) al armazón del retorno del recato (10) usando cuatro pernos M6 x 15 mm (J). (Vea Diagrama 16)

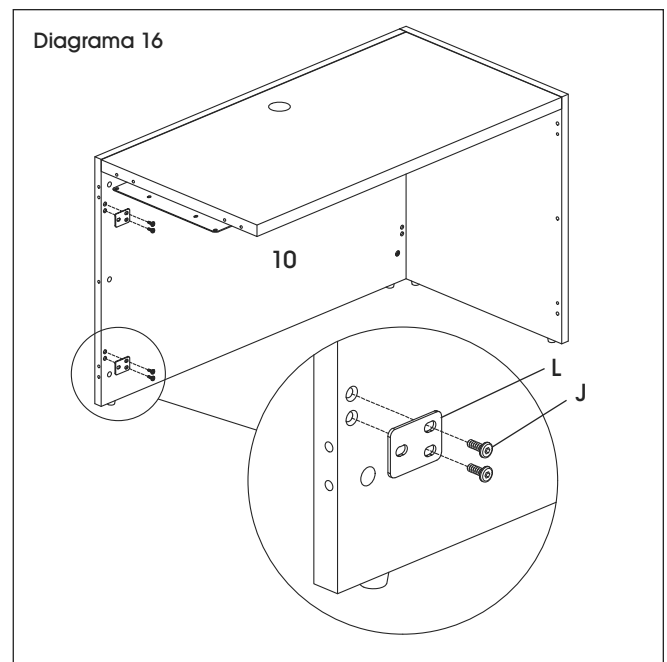

CONTINUACIÓN DEL ENSAMBLE DEL ESCRITORIO EN L

8. Cubra los orificios expuestos con tapas para orificio (M, N, y O) y las tapas de las patas (F). Inserte el ojal (G) en la cubierta del retorno. (Vea Diagrama 17)

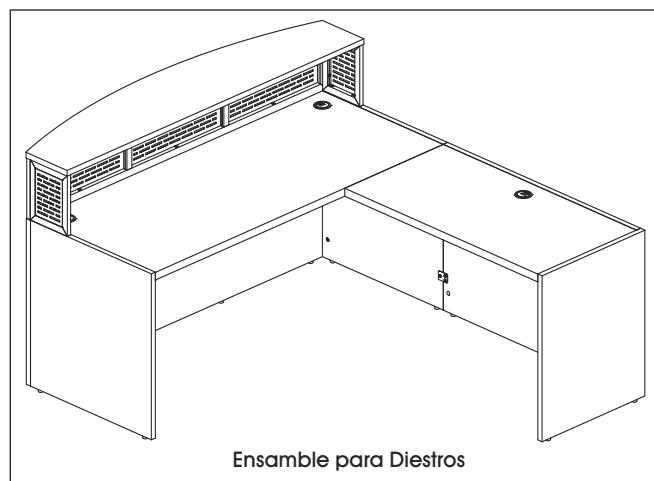
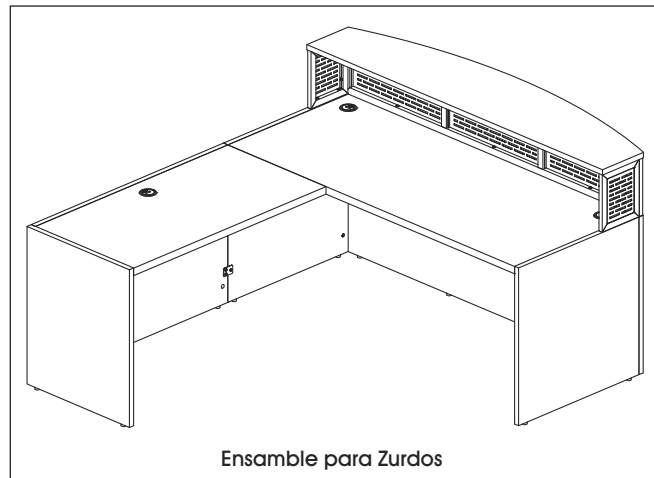
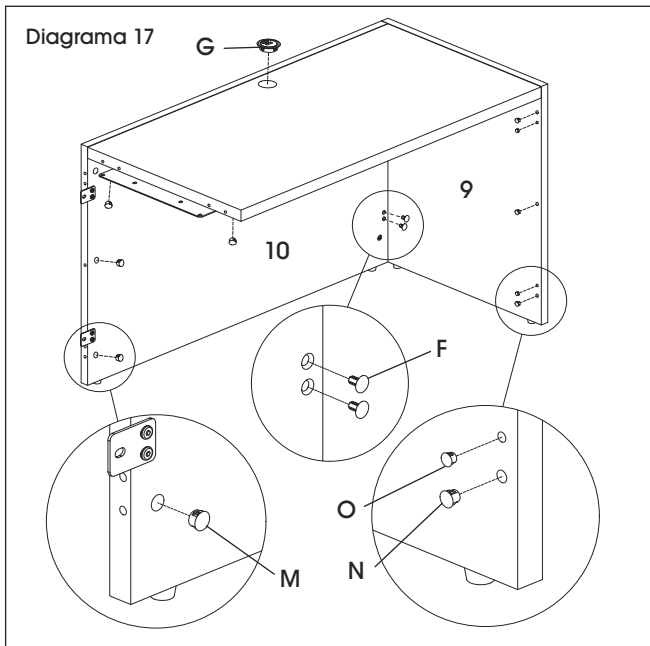

9. Con ayuda de una segunda persona, coloque el retorno del Escritorio en L al lado del escritorio ensamblado. Fije la placa conectora (K) al escritorio (1) con cuatro pernos M6 x 15 mm (J). Instale los Soportes en I (L) al panel lateral del escritorio con dos pernos M6 x 15 mm (J). (Vea Diagrama 18)

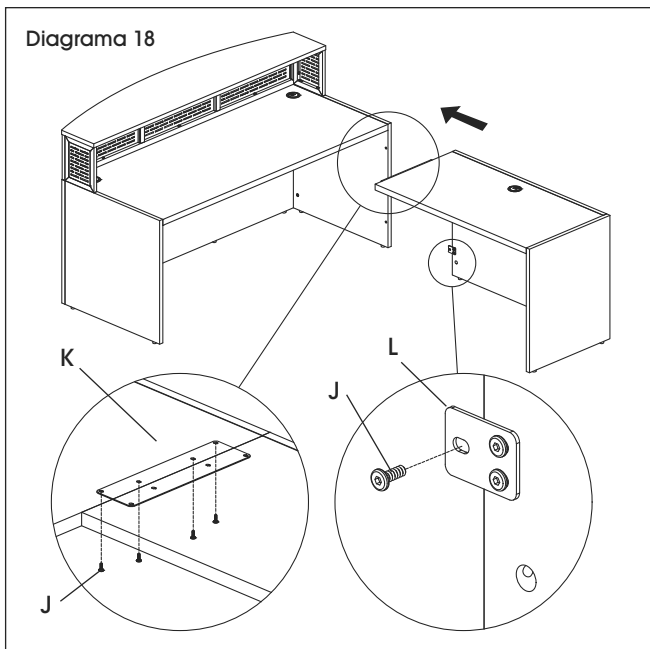

ULINE H-11732, H-11733

COLLECTION METRO – BUREAU DE RÉCEPTION

1 800 295-5510
uline.ca

OUTILS REQUIS

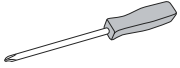

Tournevis
cruziforme



Clé hexagonale
de 4 mm (inclus)



Montage à deux
personnes recommandé

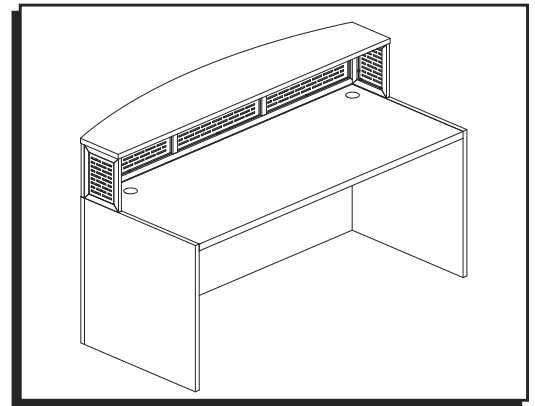

PIÈCES

A

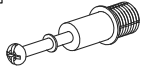

Goujon d'excentrique x 16

B



Excentrique x 16

C

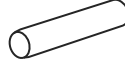

Cheville x 16

D



Cache pour
excentrique x 16

E



Patin de nivellement
x 8

F



Capuchon de pied
x 4

G



Passe-fil x 2

H



Support
métallique x 6

I

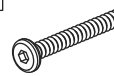

Boulon M6 x 45 mm
x 18

J



Boulon M6 x 15 mm
x 24

ÉLÉMENTS POUR LE MONTAGE DU BUREAU

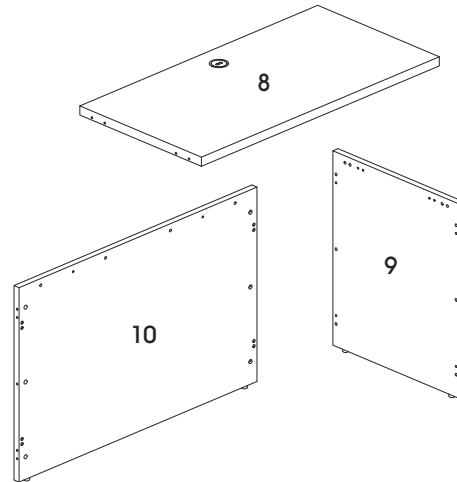
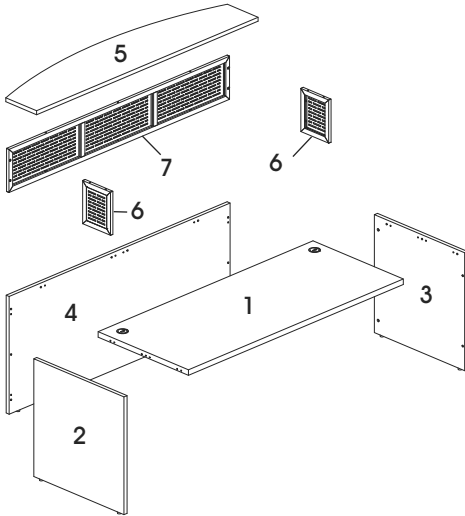

PIÈCES DU BUREAU

#	DESCRIPTION	QTÉ
1	Dessus de bureau	1
2	Panneau latéral gauche	1
3	Panneau latéral droit	1
4	Panneau cache-jambes	1
5	Panneau de comptoir	1
6	Panneau de séparation latéral pour huche	2
7	Panneau de séparation avant pour huche	1

PIÈCES DU RETOUR DE BUREAU EN L OPTIONNEL

#	DESCRIPTION	QTÉ
8	Dessus du retour de bureau	1
9	Panneau latéral du retour	1
10	Panneau cache-jambes du retour	1

MONTAGE



REMARQUE : Vérifiez que toutes les pièces sont incluses.



REMARQUE : Montez le bureau sur une surface lisse qui ne marque pas afin d'éviter les rayures. Utilisez la clé Allen pour serrer les boulons. Utilisez un tournevis cruciforme pour serrer les goujons d'excentrique et les excentriques.



IMPORTANT! Vérifiez que la flèche pointe vers le bord du panneau avant d'insérer l'excentrique dans le trou du panneau. Tournez l'excentrique de 1/4 de tour vers la droite pour le verrouiller.

IMPORTANT! FONCTIONNEMENT DES EXCENTRIQUES

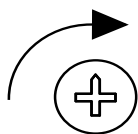

1/4 DE TOUR VERS LA DROITE POUR VERROUILLER

Vérifiez que la flèche pointe vers le bord du panneau avant de l'insérer dans le trou du panneau.



IMPORTANT! Les goujons d'excentrique doivent être serrés après insertion dans le panneau. Pour les serrer, saisissez la partie inférieure du goujon et serrez avec un tournevis cruciforme.

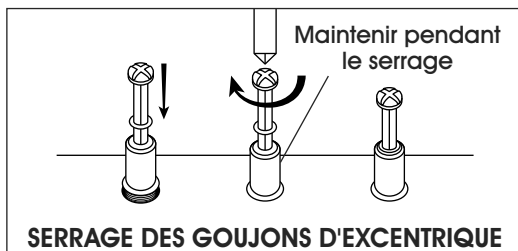

1. Installez trois goujons d'excentrique (A), quatre chevilles (C) et deux patins de nivellement (E) dans chaque panneau latéral (2, 3). (Voir Figure 1)

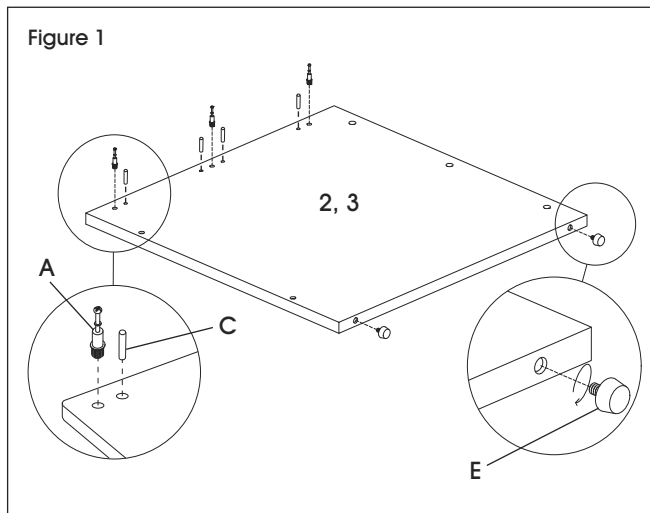

2. Insérez six excentriques (B) dans le dessus de table (1). Fixez les panneaux latéraux (2, 3) au dessus de table (1), puis tournez chaque excentrique dans le sens horaire avec un tournevis cruciforme jusqu'à ce qu'il se verrouille. (Voir Figure 2)



REMARQUE : Une fois les excentriques serrés, les caches pour excentrique (D) peuvent être installés pour donner un aspect fini.

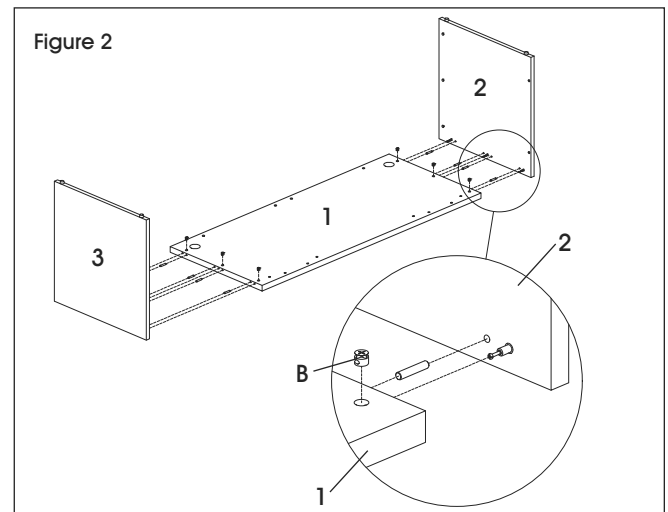

3. Installez 10 goujons d'excentrique (A), huit chevilles (D) et quatre patins de nivellement (E) dans le panneau cache-jambes (4). (Voir Figure 3)

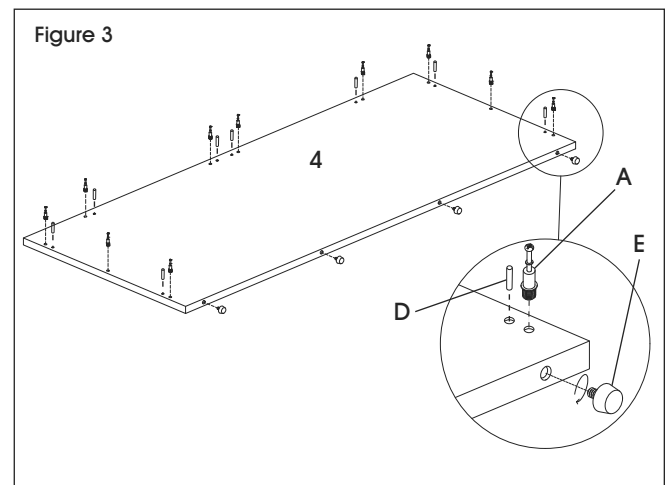

MONTAGE SUITE

4. Installez 10 excentriques (B) dans le dessus de table (1) et les panneaux latéraux (2, 3). Fixez le panneau cache-jambes (4) à l'ensemble du dessus de table et des panneaux latéraux. (Voir Figure 4)

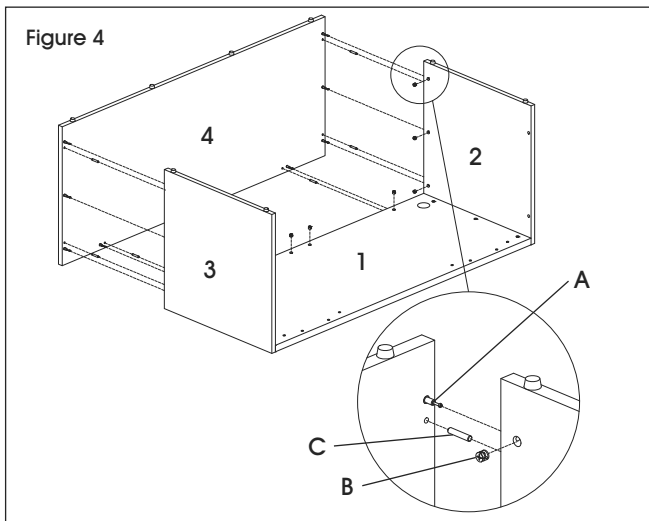

5. Installez six supports métalliques (H) sur le bureau monté à l'aide de 24 boulons M6 x 15 mm (J). À deux, mettez le bureau assemblé à l'endroit. (Voir Figure 5)

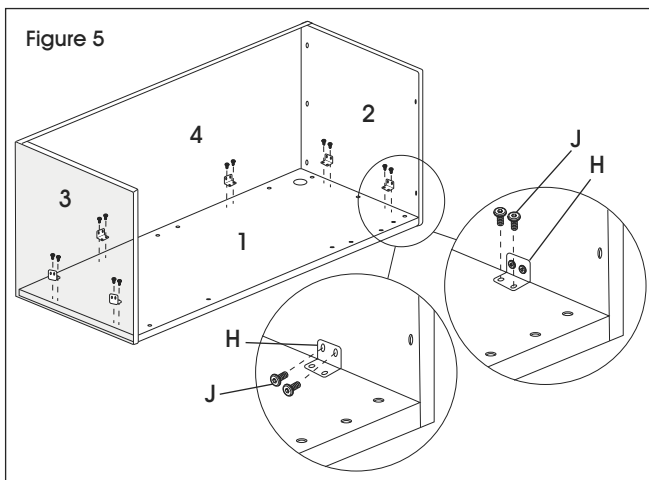

6. Fixez les panneaux de séparation latéraux de la huche (6) au panneau avant (7) à l'aide de quatre boulons M6 x 45 mm (I). (Voir Figure 6)

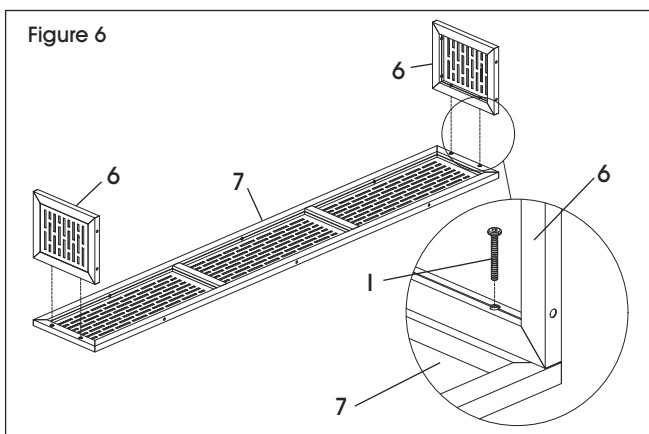

7. Placez le panneau de comptoir (5) à l'envers avec les trous vers le haut. À deux, placez la huche de séparation sur le panneau de comptoir et utilisez sept boulons M6 x 45 mm (I) pour la fixer. (Voir Figure 7)

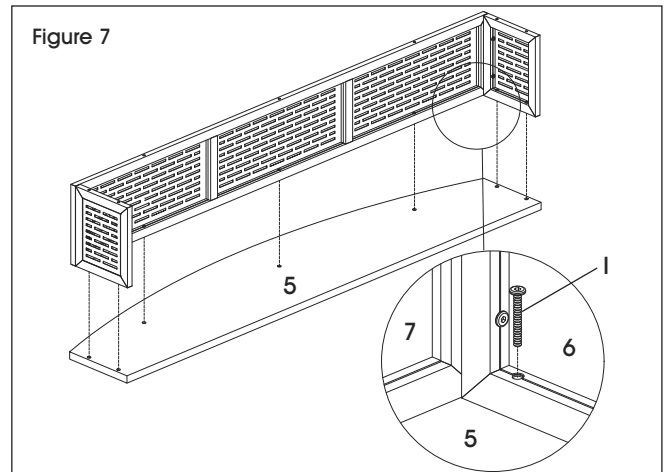

8. À deux, tournez le guichet monté à l'endroit. Fixez-le au bureau monté avec sept boulons M6 x 45 mm (I). Installez les capuchons de pied (F) pour donner un aspect fini. (Voir Figure 8)

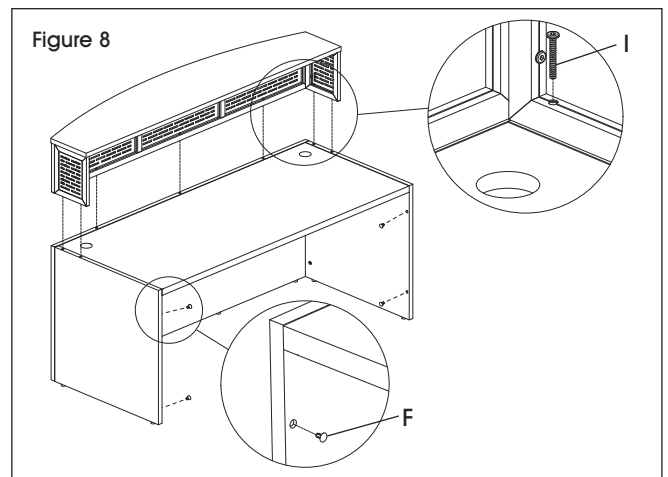

9. Insérez les passe-fils (G) dans le dessus de bureau. (Voir Figure 9)

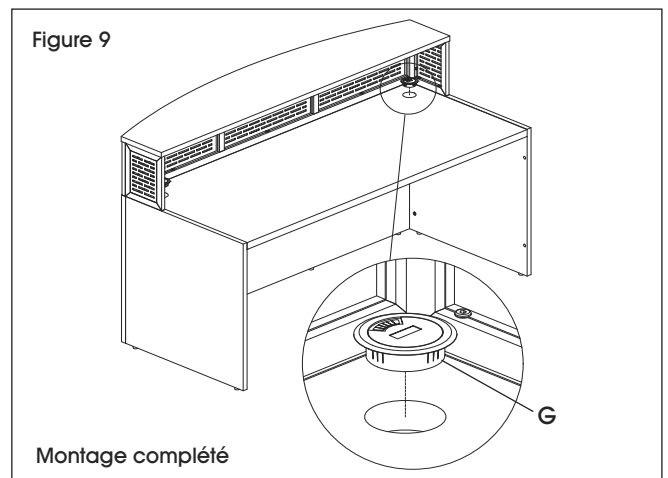

PIÈCES POUR LE MONTAGE DU RETOUR DE BUREAU EN L

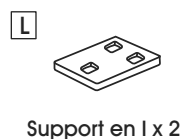
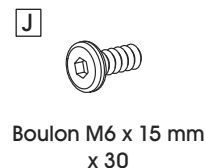
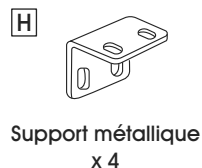
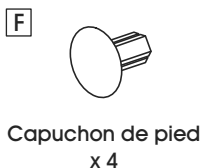
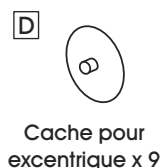
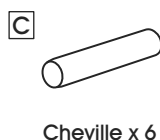
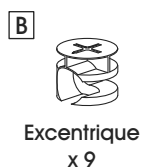
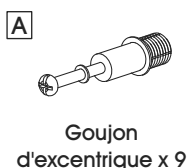

MONTAGE DU BUREAU EN L



REMARQUE : Déterminez si le bureau en L sera configuré à droite ou à gauche. Cela aura un impact sur la façon dont le retour est monté. Le montage du bureau en L avec configuration à droite est indiqué dans les illustrations suivantes.

1. Installez quatre goujons d'excentrique (A), deux chevilles (C) et deux patins de nivellement (E) dans le panneau cache-jambes du retour (10). (Voir Figure 10)

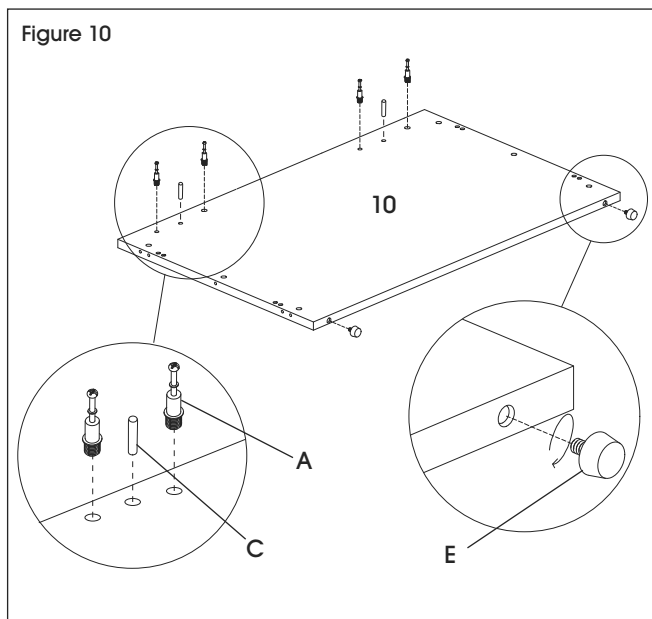

2. Installez quatre excentriques (B) sur le bureau de retour (8). Fixez le bureau de retour (8) au panneau de fond de retour (10). (Voir Figure 11)

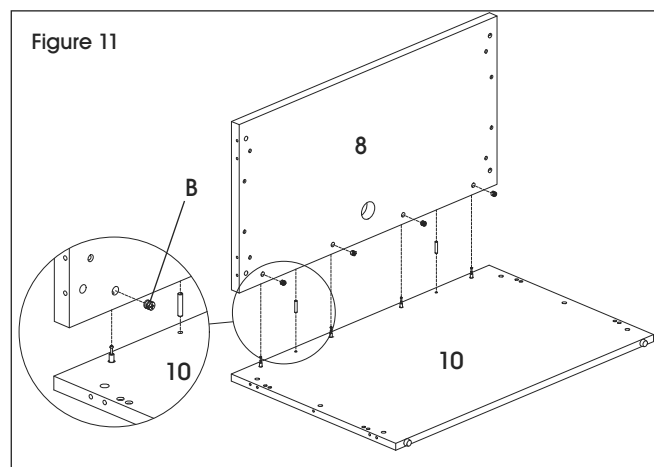

3. Insérez cinq goujons d'excentrique (A), quatre chevilles (C) et deux patins de nivellement (E) dans le panneau latéral du retour (9). (Voir Figure 12)

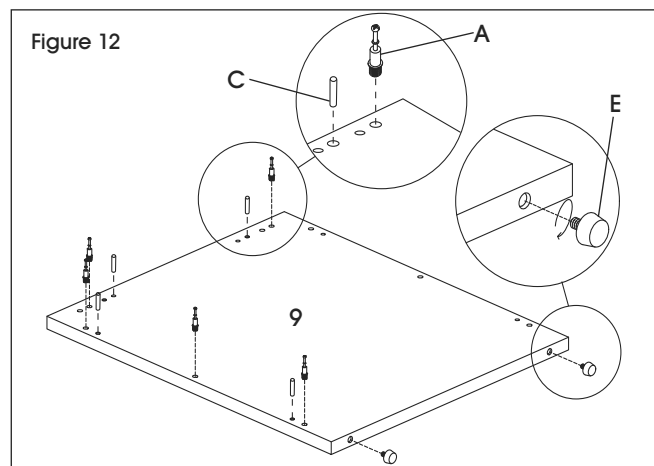

MONTAGE DU BUREAU EN L SUITE

4. Insérez cinq excentriques (B) dans le retour de bureau (8) et le panneau cache-jambes (10). Fixez le panneau latéral du retour au panneau cache-jambes du retour et au dessus du retour de bureau. Tournez chaque excentrique (B) dans le sens horaire jusqu'à ce qu'il se verrouille. (Voir Figure 13)

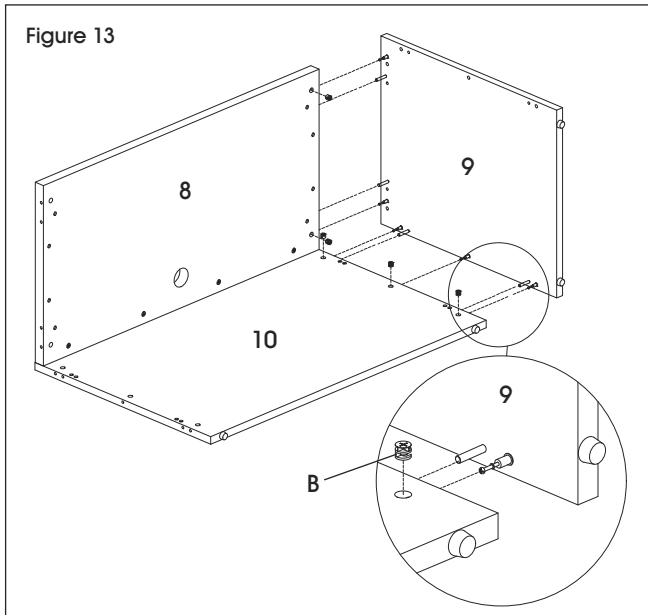

5. Installez quatre supports métalliques (H) sur le retour monté (8, 9, 10) à l'aide de 16 boulons M6 x 15 mm (J). (Voir Figure 14)

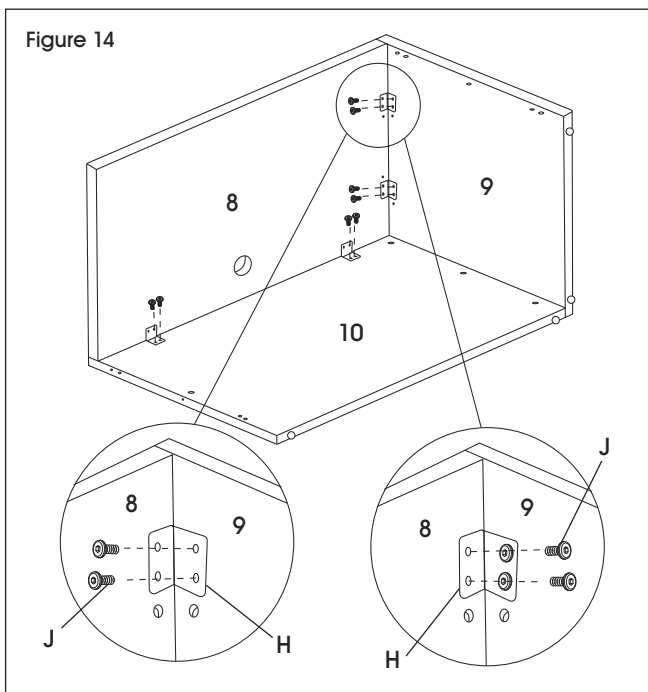

6. Fixez la plaque de connexion (K) sur le dessus du retour de bureau (8) avec quatre boulons M6 x 15 mm (J). (Voir Figure 15)

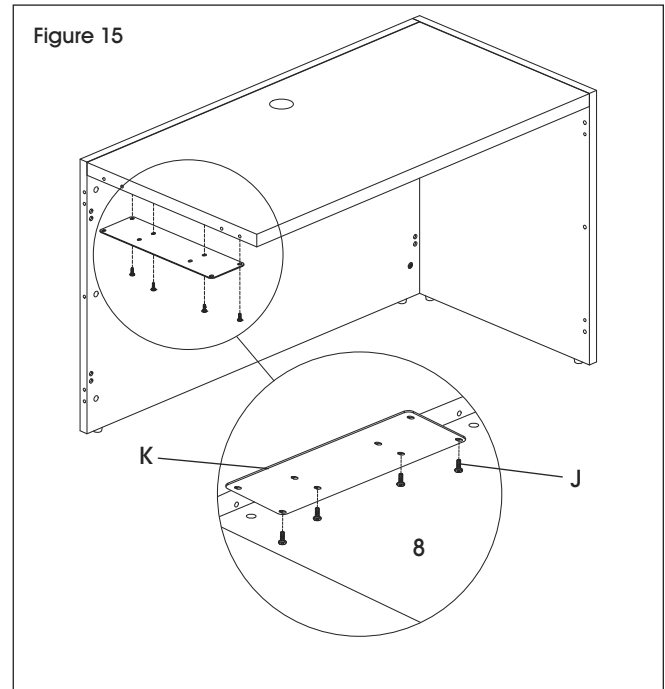

7. Installez deux supports en L (L) sur le panneau cache-jambes du retour (10) à l'aide de quatre boulons M6 x 15 mm (J). (Voir Figure 16)

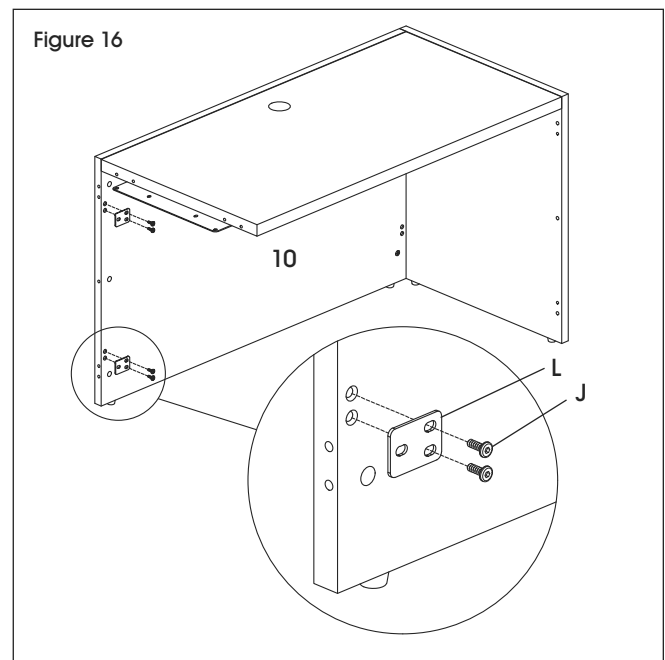

MONTAGE DU BUREAU EN L SUITE

8. Recouvrez les trous à découvert à l'aide de caches pour trou (M, N et O) et de capuchons de pied (F). Insérez le passe-fil (G) dans le dessus du retour. (Voir Figure 17)

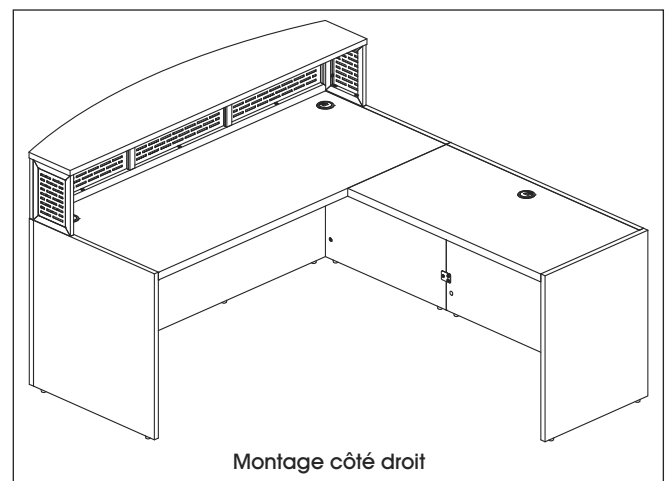
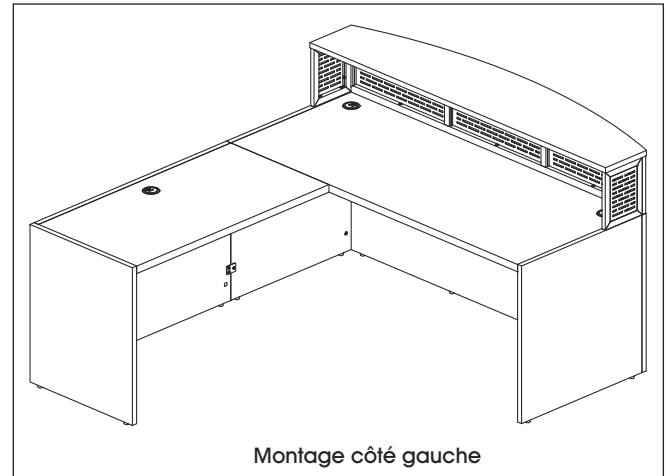
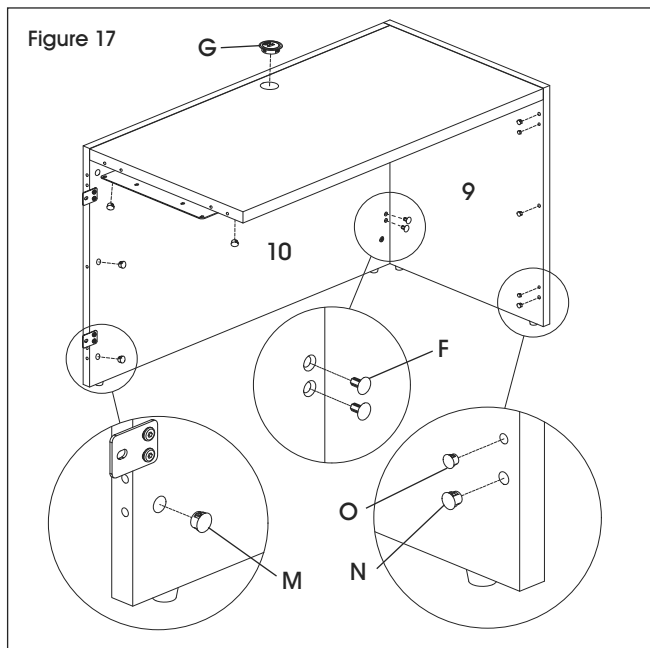

9. À deux, placez le retour de bureau en L à côté du bureau monté. Fixez la plaque de connexion (K) sur le dessus du bureau (1) avec quatre boulons M6 x 15 mm (J). Fixez les supports en I (L) au panneau latéral du bureau à l'aide de deux boulons M6 x 15 mm (J). (Voir Figure 18)

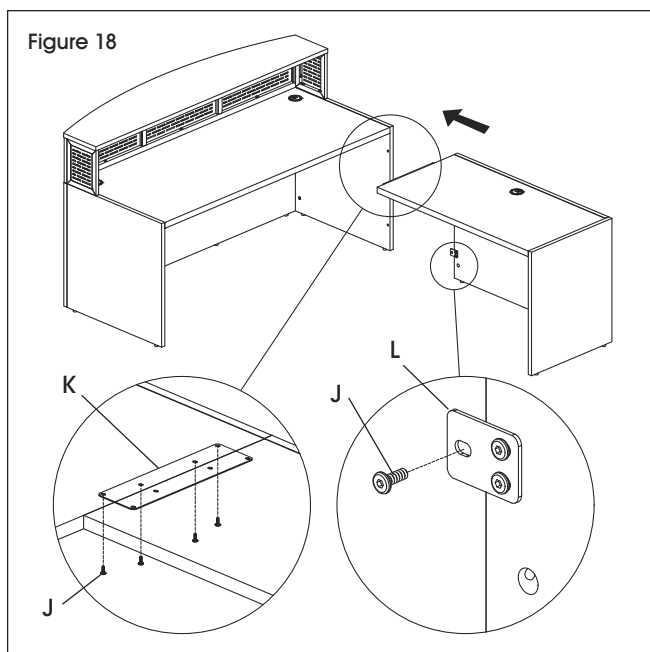

ULINE

1 800 295-5510

uline.ca