

# ULINE H-11829

## DOWNTOWN COLLECTION

### BREAKROOM CART

1-800-295-5510  
uline.com

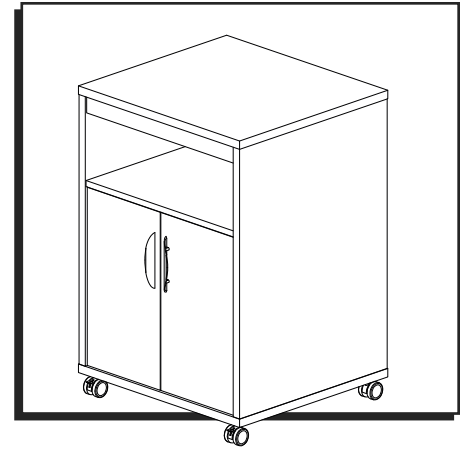

### TOOLS NEEDED

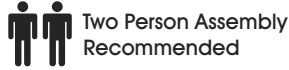
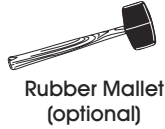
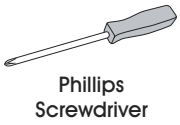

## PARTS

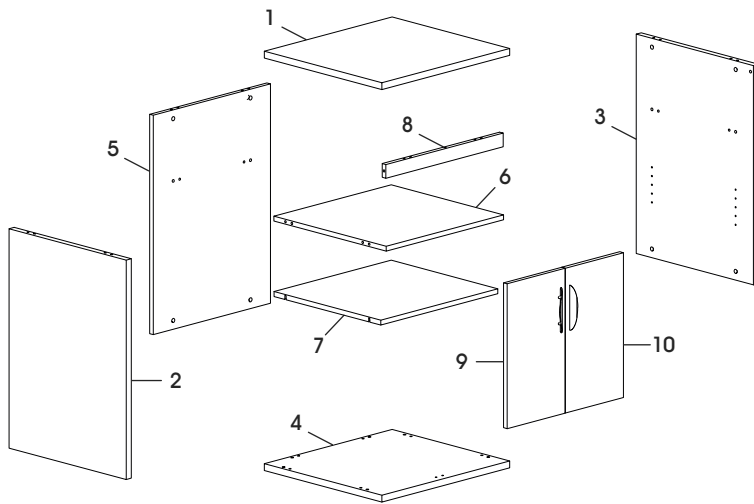

### PARTS

#	DESCRIPTION	QTY.
1	Top Panel	1
2	Left Side Panel	1
3	Right Side Panel	1
4	Bottom Panel	1
5	Back Panel	1
6	Upper Shelf	1
7	Lower Shelf	1
8	Top Rail Panel	1
9	Left Door	1
10	Right Door	1

## HARDWARE

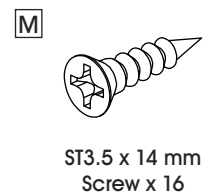
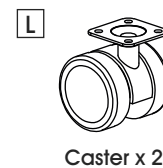
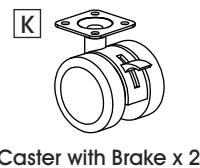
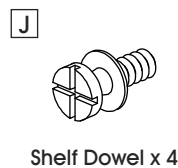
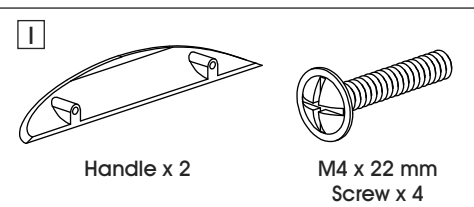
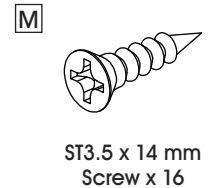
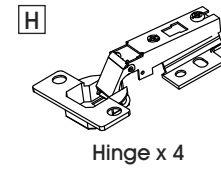
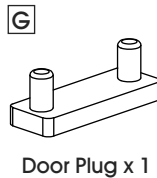
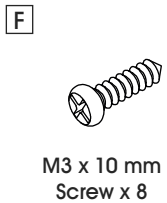
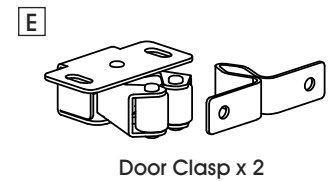
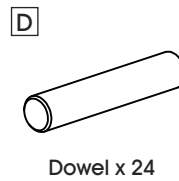
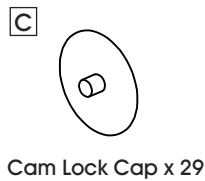
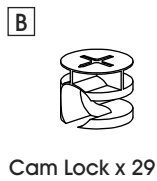
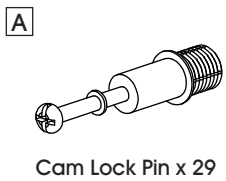

# ASSEMBLY

 **NOTE:** Assemble unit on a smooth, non-marring surface to prevent scratching. Check that all parts are included.

 **IMPORTANT!** Turn cam lock 1/4 to the right to lock.

## IMPORTANT! FUNCTION OF CAM LOCK



Ensure the arrow is pointing toward edge of panel before inserting into the panel's hole.

 **IMPORTANT!** Cam lock pins must be tightened once inserted into panel. To tighten cam lock pins, grasp lower part of cam lock pin and tighten using a Phillips screwdriver.

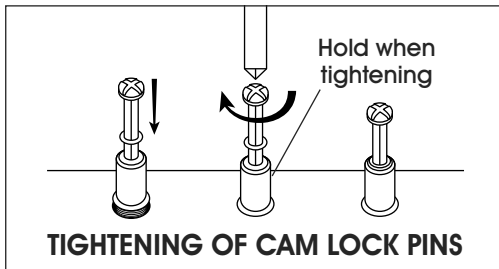

 **NOTE:** Use Phillips screwdriver to tighten cam locks, cam lock pins and screws.

 **NOTE:** Cam lock caps can be applied once cam locks are tightened for a finished look.

1. Install two cam lock pins (A), two cam locks (B) and two dowels (D) in corresponding holes in back panel (5) and upper shelf (6). Attach shelf to back panel as shown. Tighten cam locks using Phillips screwdriver. (See Figure 1)

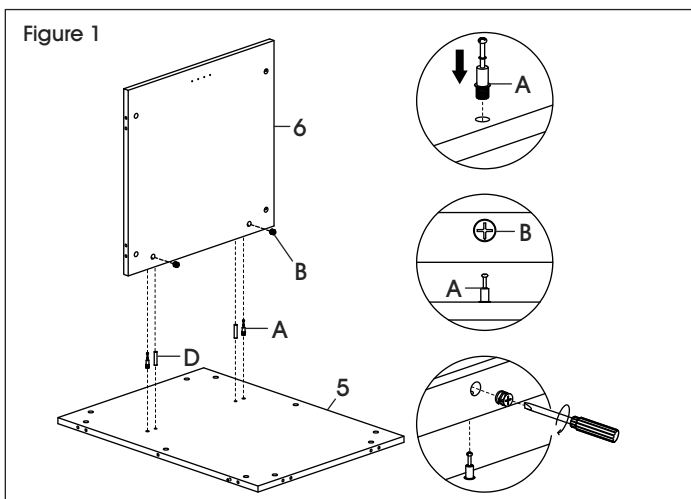

2. Install 12 cam lock pins (A) into corresponding holes in side panels (2, 3). (See Figure 2)

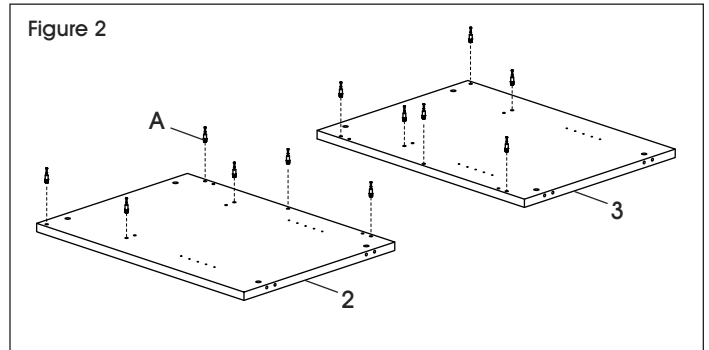

3. Attach left side panel (2) to back panel (5) and upper shelf (6) with five cam locks (B) and four dowels (D). Tighten cam locks. (See Figure 3)

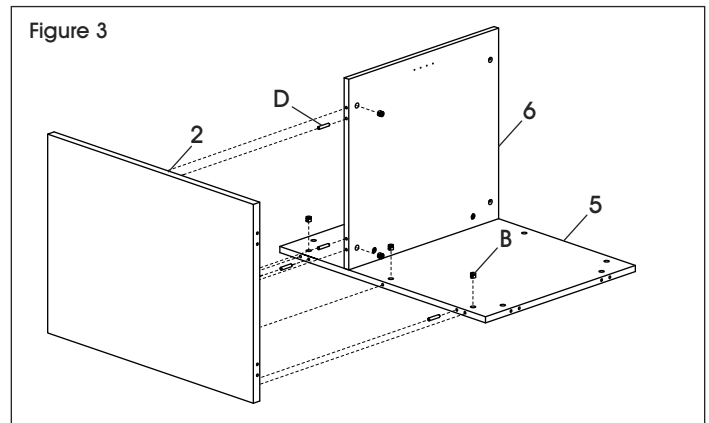

4. Attach top rail panel (8) to left side panel (2) with one cam lock (B). Tighten cam lock. (See Figure 4)

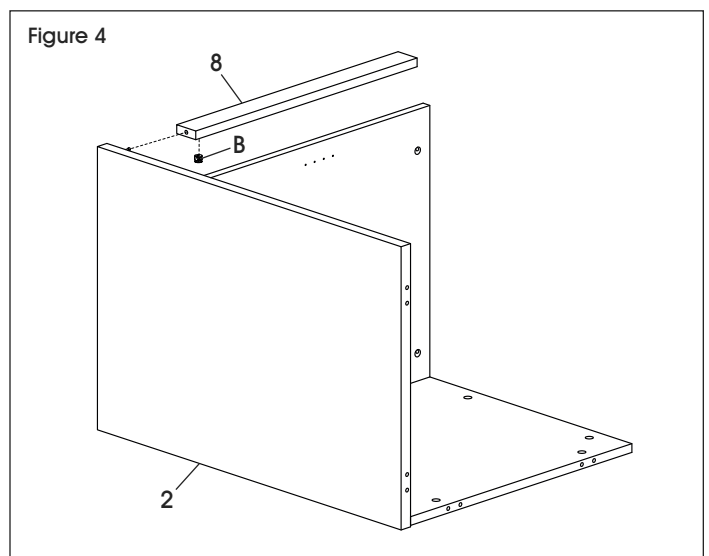

## ASSEMBLY CONTINUED

5. Attach right side panel (3) to previously assembled panels with four dowels (D) and six cam locks (B). Tighten cam locks. (See Figure 5)

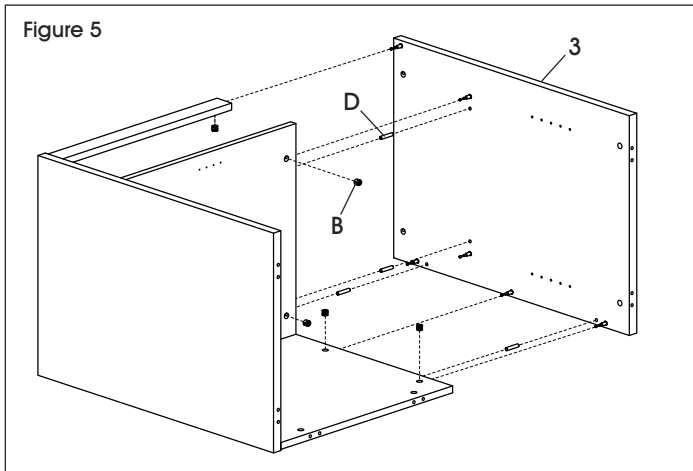

7. Install nine cam locks (B) and attach top panel (1) to previously assembled panels. Tighten cam locks. (See Figure 7)

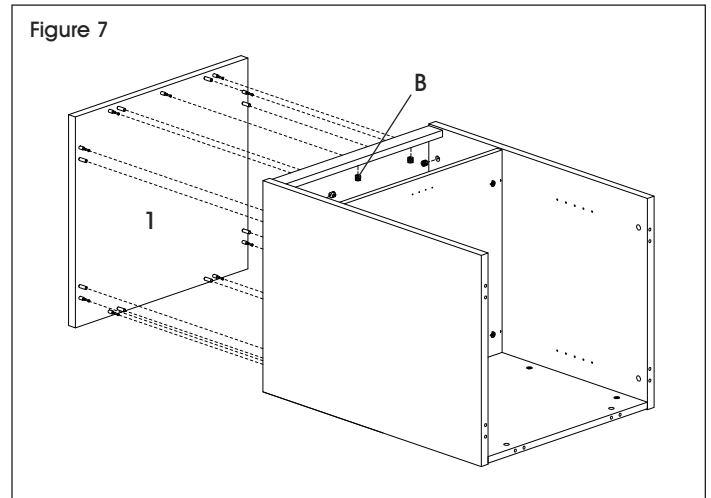

6. Install nine cam lock pins (A) and eight dowels (D) into top panel (1). (See Figure 6)

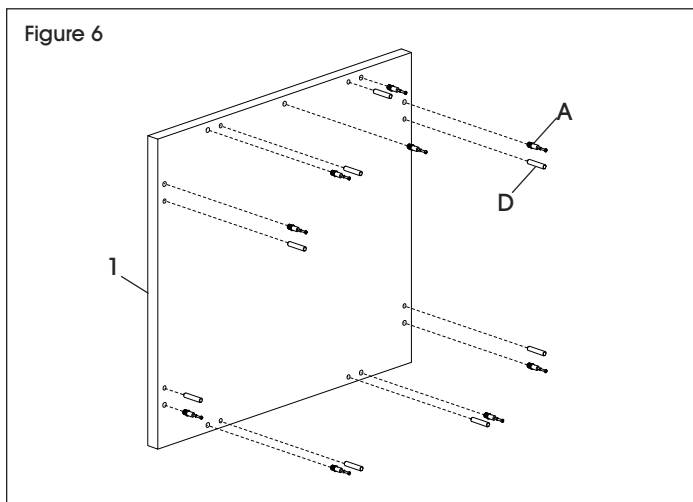

8. Install six cam lock pins (A) and six dowels (D) to bottom panel (4). (See Figure 8)

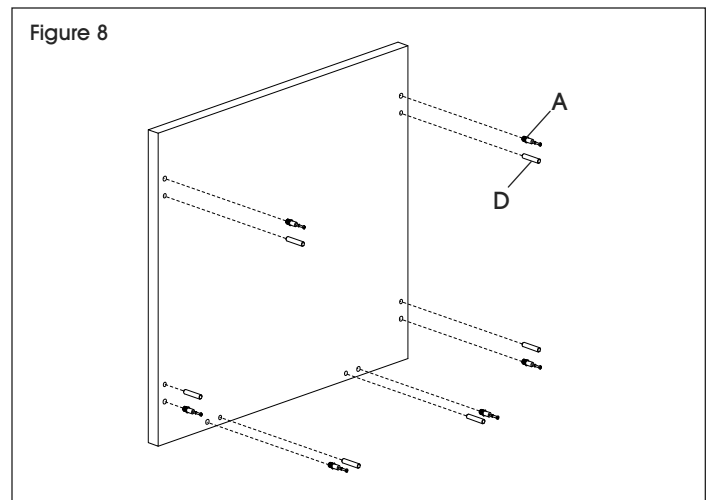

## ASSEMBLY CONTINUED

9. Install six cam locks (B) and attach bottom panel (4) to previously assembled panels. Tighten cam locks. (See Figure 9)

Figure 9

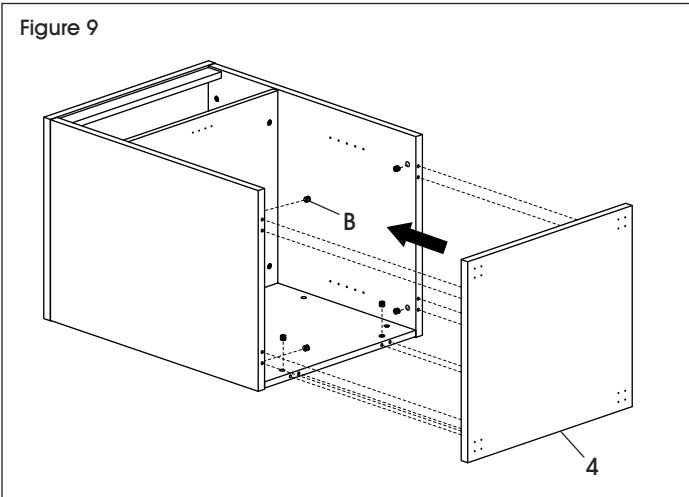

10. Attach casters with brake (K) to front of bottom panel (4) and casters without brake to back of bottom panel using four ST3.5 x 14 mm screws (M) per caster. (See Figure 10)

Figure 10

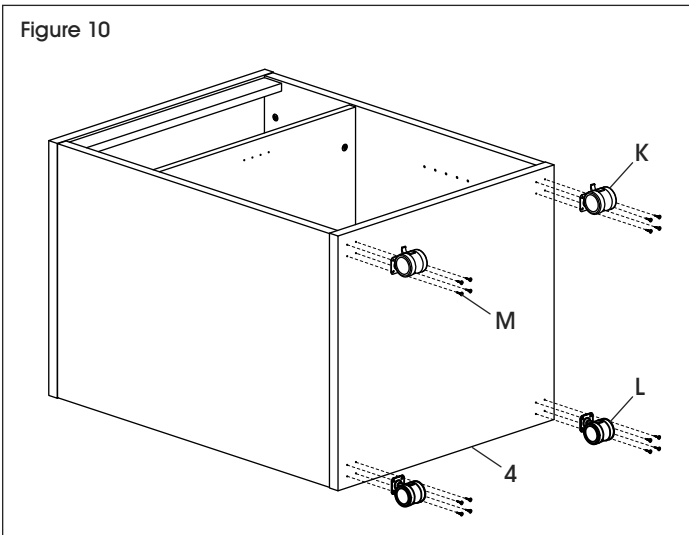

11. Install door clasp claw (E) onto bottom of upper shelf (6) using two M3 x 10 mm screws (F). (See Figure 11)

Figure 11

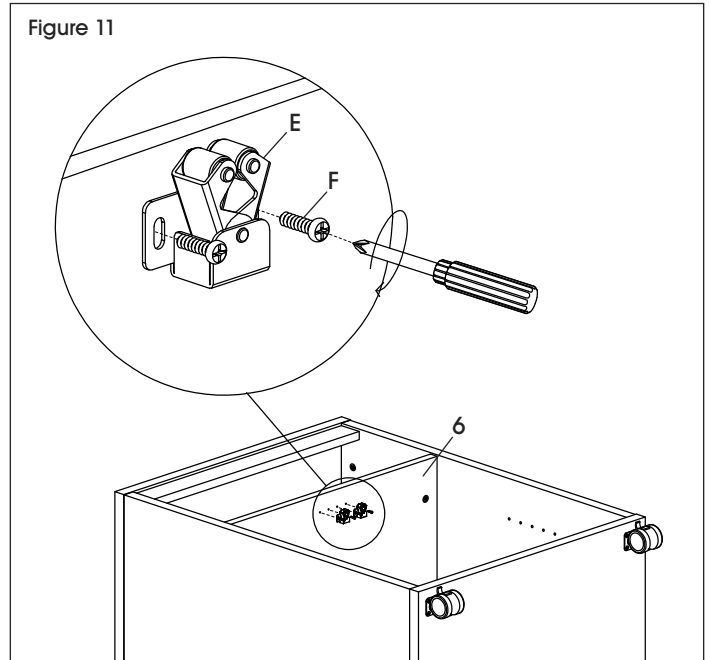

12. Install two shelf dowels (J) at desired height in side panel. Repeat for opposite side panel. Insert lower shelf (7). (See Figure 12)

Figure 12

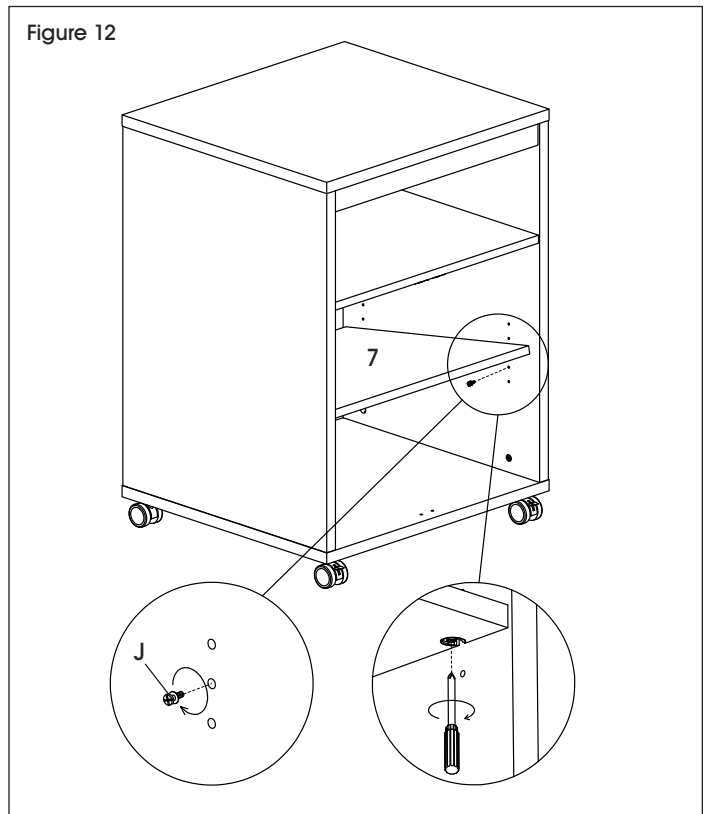

## ASSEMBLY CONTINUED

13. Install door plug (G) on bottom panel (4).  
Use a rubber mallet if necessary. (See Figure 13)

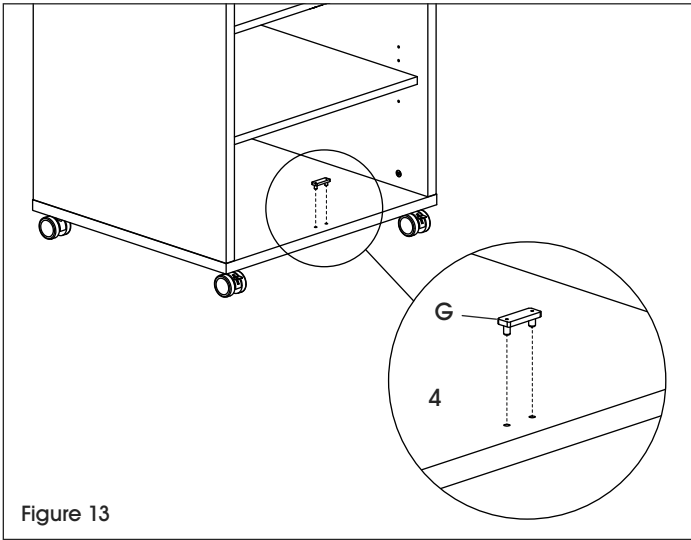

14. Install cam lock caps (C) on all cam locks.  
(See Figure 14)

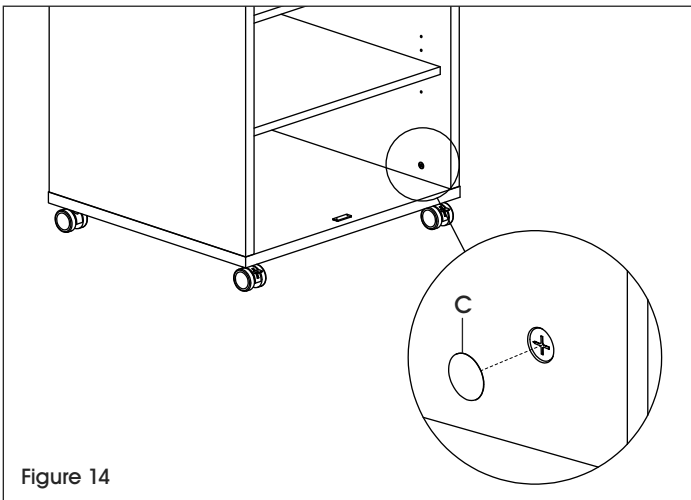

15. Install hinges (H) onto door (9) using four M4 x 10 mm screws (H). Install door handle (I) using two M4 x 22 mm screws (I). Repeat for remaining door. (See Figure 15)

 **NOTE:** Ensure handles face the correct direction with handle opening facing out when doors are closed.

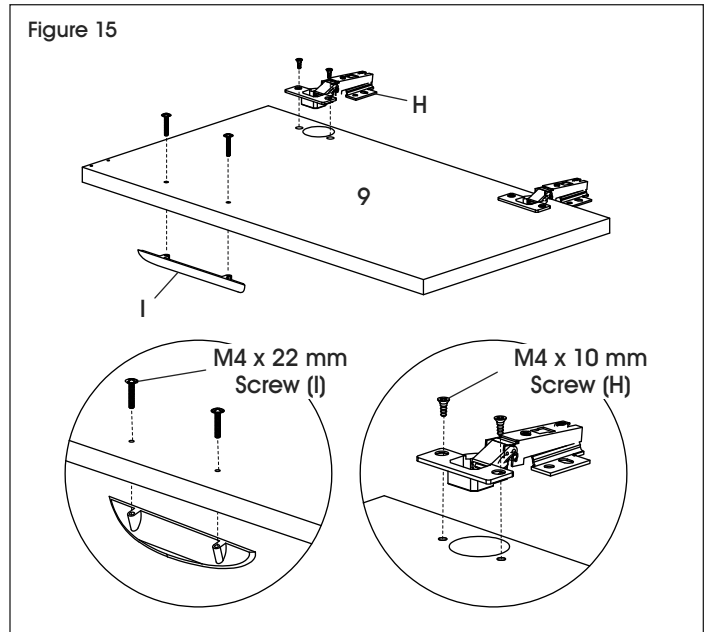

16. Install door clasp prongs onto door panel (9) using two M3 x 10 mm screws (F). Repeat for remaining door. (See Figure 16)

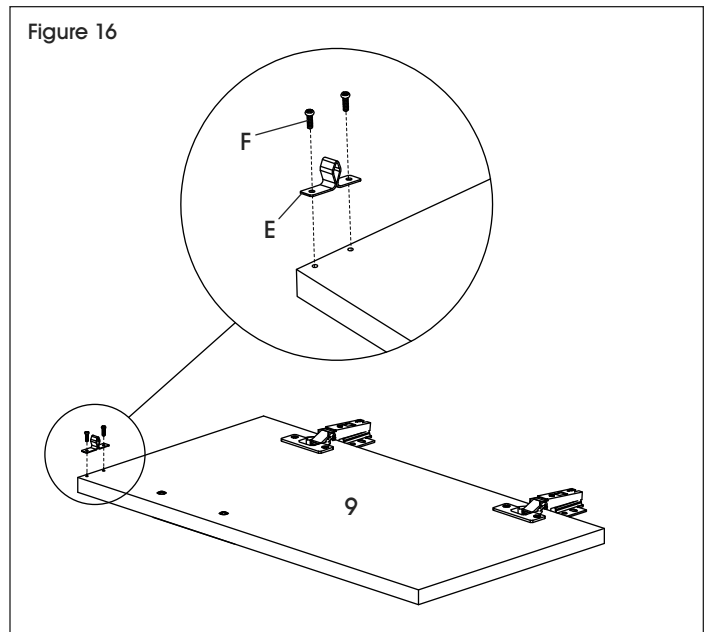

## ASSEMBLY CONTINUED

17. Attach doors (9, 10) to cart using eight ST3.5 x 14 mm screws (M) per door. (See Figure 17)

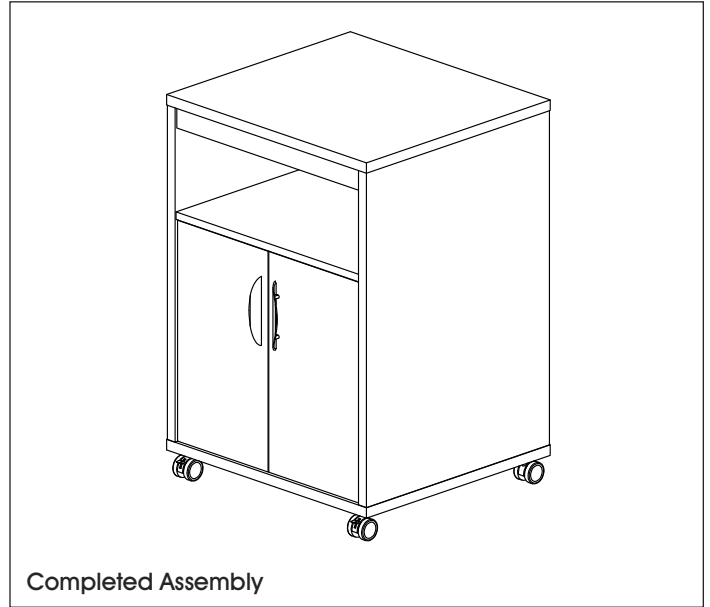
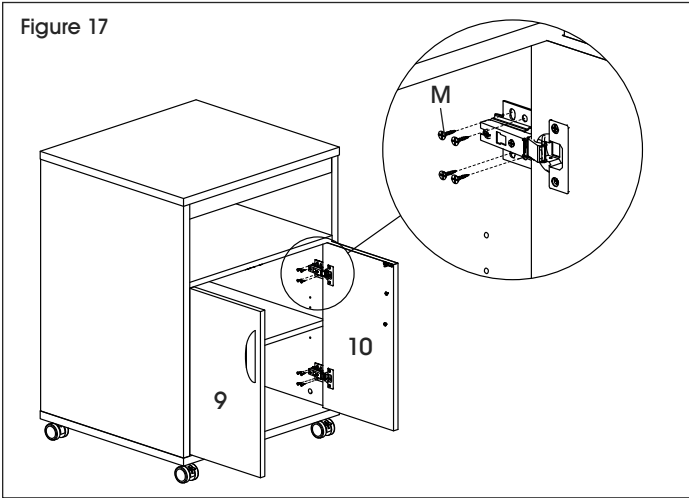

18. Adjust the height, depth and gap of doors as needed. Assembly is now complete. (See Figure 18)

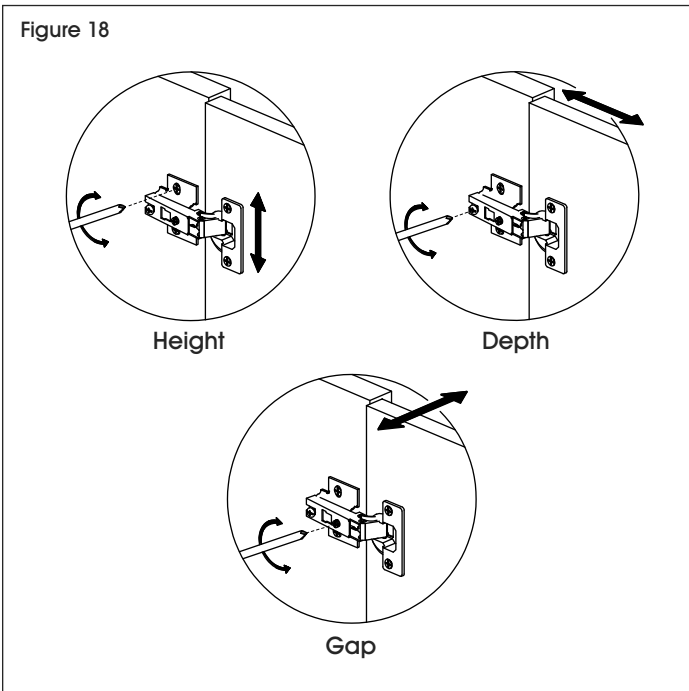

**ULINE H-11829**  
**COLECCIÓN URBANA**  
 CARRITO DE ÁREAS DE DESCANSO

800-295-5510  
 uline.mx

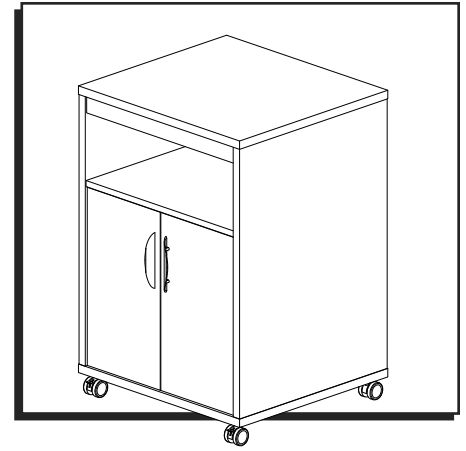

Se recomienda Armar Entre Dos Personas

**PARTES**

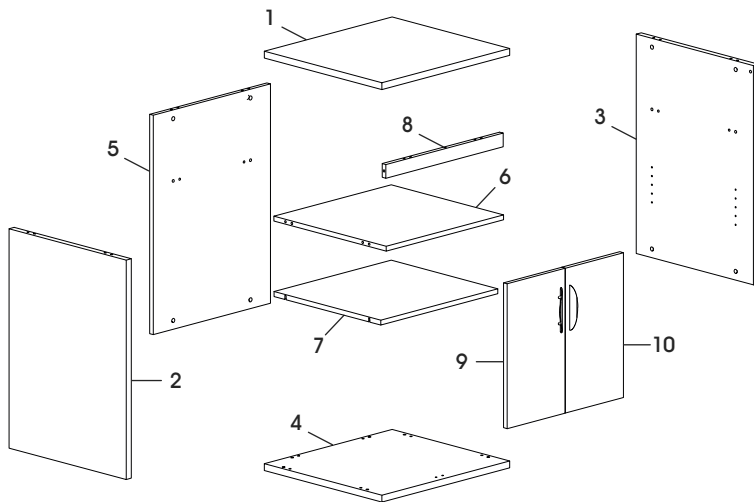

**PARTES**

#	DESCRIPCIÓN	CANT.
1	Panel Superior	1
2	Panel Lateral Izquierdo	1
3	Panel Lateral Derecho	1
4	Panel Inferior	1
5	Panel Posterior	1
6	Repisa Superior	1
7	Repisa Inferior	1
8	Panel de Riel Superior	1
9	Puerta Izquierda	1
10	Puerta Derecha	1

**TORNILLERÍA**

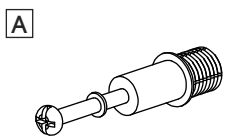

29 Pasadores para Tuercas Minifix

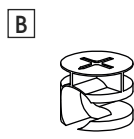

29 Tuercas Minifix

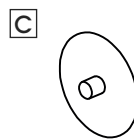

29 Tapas para Tuercas Minifix

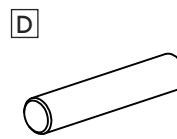

24 Taquetes

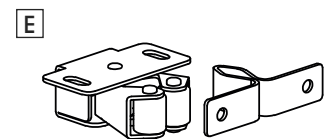

2 Broches para Puerta

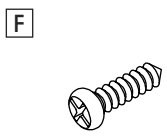

8 Tornillos M3 x 10 mm

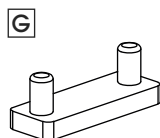

1 Tapón para Puerta

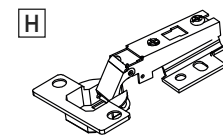

4 Bisagras



8 Tornillos M4 x 10 mm

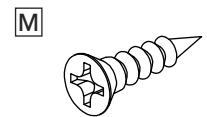

16 Tornillos ST3.5 x 14 mm

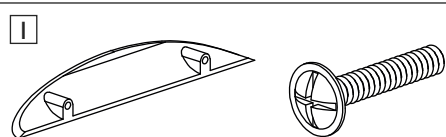

2 Asas

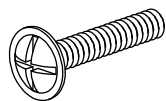

4 Tornillos M4 x 22 mm

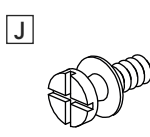

4 Taquetes para Repisa

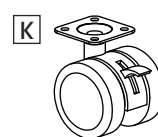

2 Ruedas Giratorias con Freno

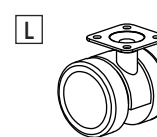

2 Ruedas

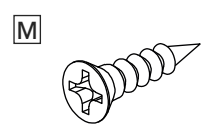

16 Tornillos ST3.5 x 14 mm

# ENSAMBLE

 **NOTA:** Ensamble la unidad sobre una superficie lisa que no deje marcas para evitar rayones. Verifique que todas las partes estén incluidas.

 **¡IMPORTANTE!** Gire la tuerca minifix 1/4 a la derecha para asegurarla.

## ¡IMPORTANTE! FUNCIÓN DE LA TUERCA MINIFIX

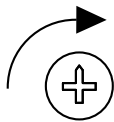

**GIRE 1/4 A LA DERECHA PARA ASEGURARLA**

Asegúrese de que la flecha apunte hacia el borde del panel antes de insertarla al orificio.

 **¡IMPORTANTE!** Los pasadores para tuercas minifix se deben apretar una vez que se inserten al panel. Para apretar los pasadores, sostenga la parte inferior del pasador y apriete con el desarmador de cruz.

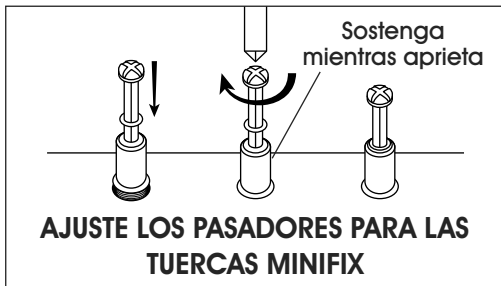

 **NOTA:** Utilice un desarmador de cruz para apretar los tornillos, las tuercas y pasadores minifix.

 **NOTA:** Puede colocar las tapas de las tuercas minifix una vez que haya apretado las tuercas para darle una apariencia terminada.

1. Instale dos pasadores para tuercas minifix (A), dos tuercas minifix (B) y dos taquetes (D) en los orificios correspondientes del panel posterior (5) y repisa superior (6). Fije la repisa al panel posterior como se muestra. Apriete todas las tuercas minifix utilizando el desarmador de cruz. (Vea Diagrama 1)

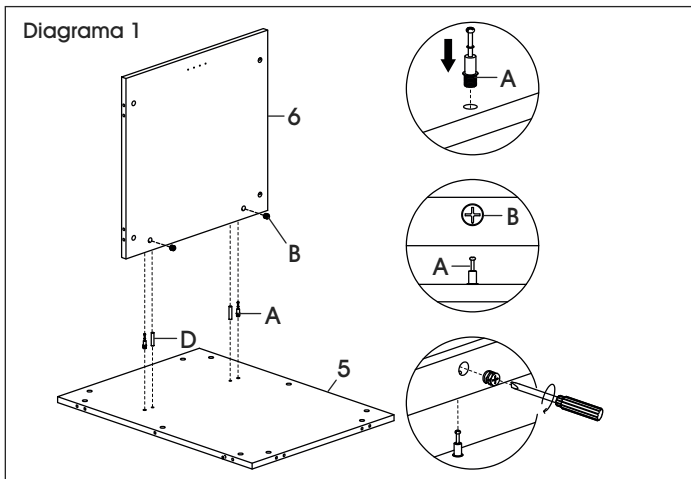

2. Instale 12 pasadores para tuercas minifix (A) en los paneles laterales (2, 3). (Vea Diagrama 2)

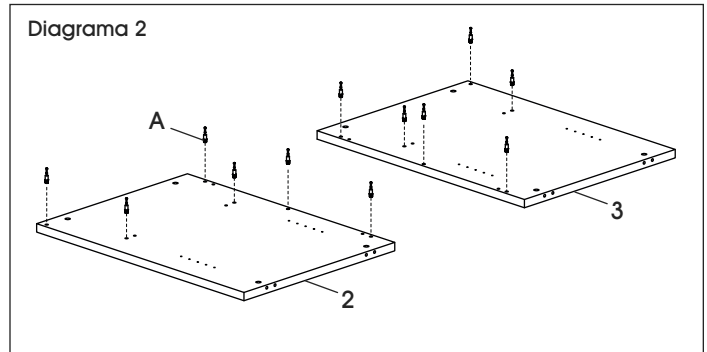

3. Fije el panel lateral izquierdo (2) al panel posterior (5) y la repisa superior (6) con cinco tuercas minifix (B) y cuatro taquetes (D). Apriete las tuercas minifix. (Vea Diagrama 3)

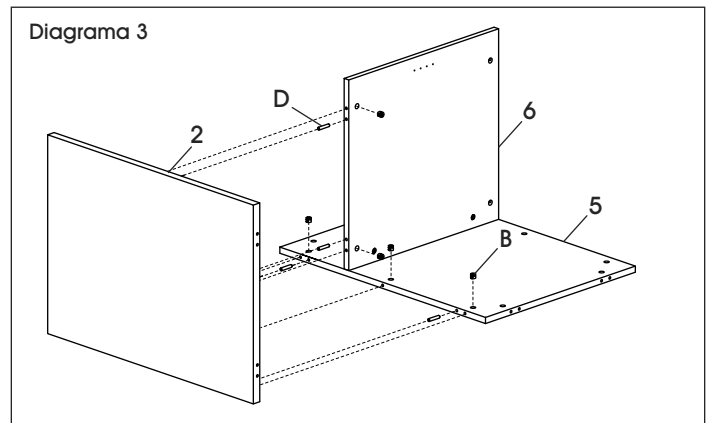

4. Fije el panel del riel superior (8) al panel lateral izquierdo (2) con una tuerca minifix (B). Apriete la tuerca minifix. (Vea Diagrama 4)

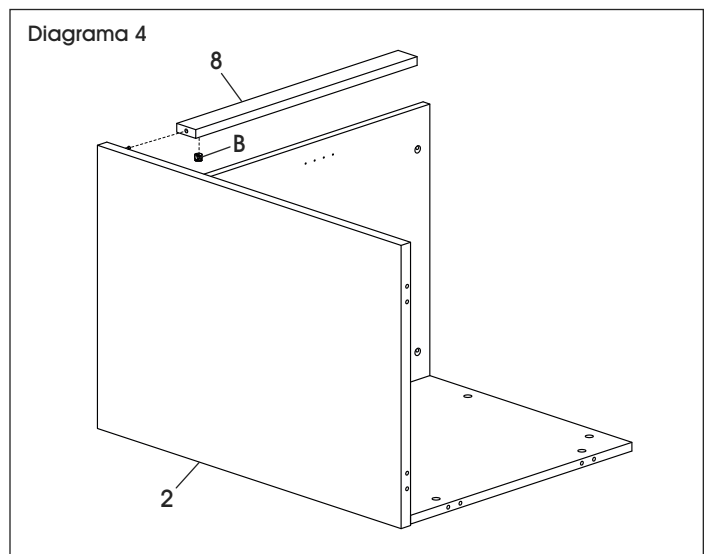



## CONTINUACIÓN DEL ENSAMBLE

5. Fije el panel lateral derecho (3) a los paneles anteriormente ensamblados con cuatro taquetes (D) y seis tuercas minifix (B). Apriete las tuercas minifix. (Vea Diagrama 5)

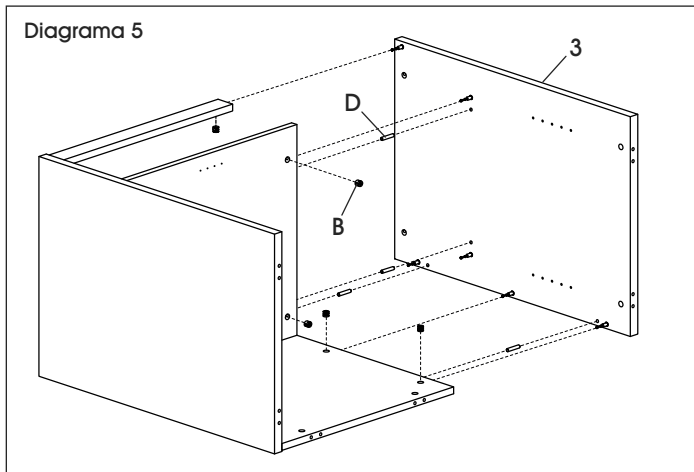

7. Instale nueve tuercas minifix (B) y fije el panel superior (1) a los paneles anteriormente ensamblados. Apriete las tuercas minifix. (Vea Diagrama 7)

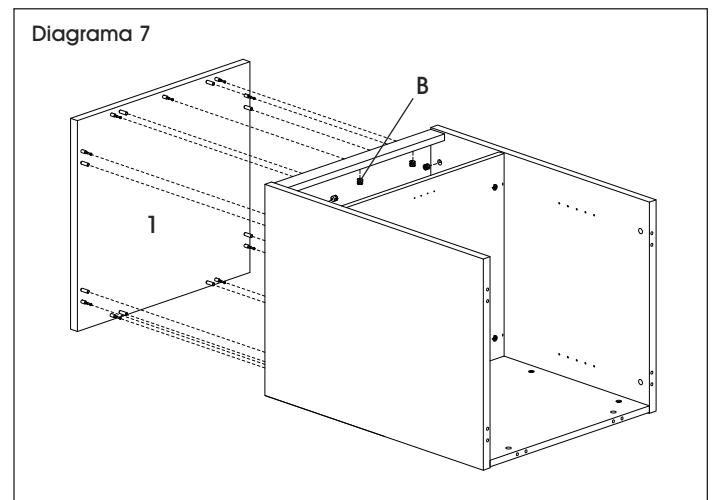

6. Instale nueve pasadores para tuercas minifix (A) y ocho taquetes (D) al panel superior (1). (Vea Diagrama 6)

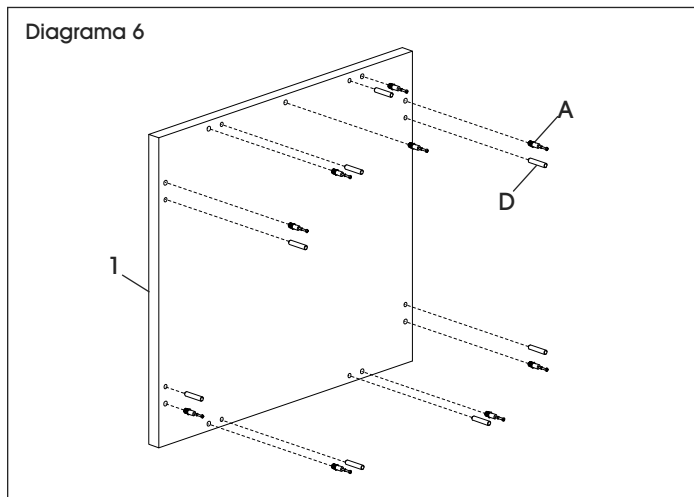

8. Instale seis pasadores para tuercas minifix (A) y ocho taquetes (D) al panel inferior (4). (Vea Diagrama 8)

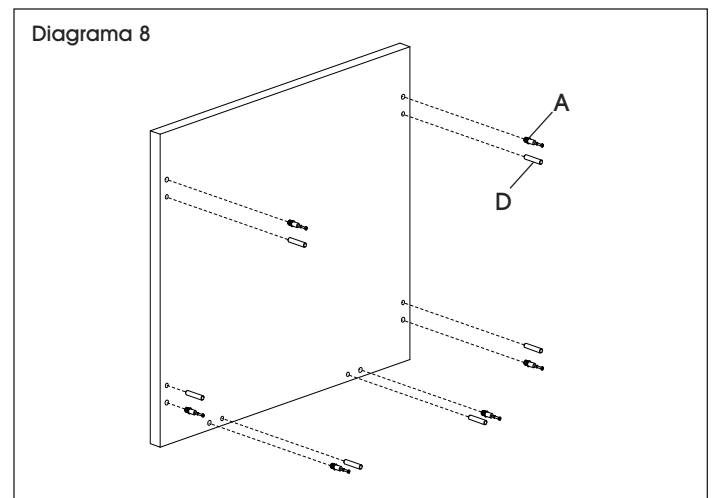

## CONTINUACIÓN DEL ENSAMBLE

9. Instale seis tuercas minifix (B) y fije el panel inferior (4) a los paneles anteriormente ensamblados. Apriete las tuercas minifix. (Vea Diagrama 9)

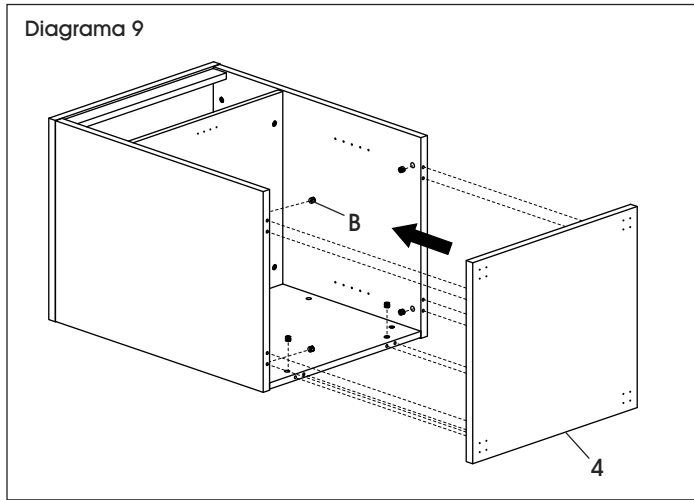

10. Fije las ruedas con freno (K) a la parte frontal del panel inferior (4) y las ruedas sin freno a la parte posterior con cuatro tornillos ST3.5 x 14 mm (M) por rueda. (Vea Diagrama 10)

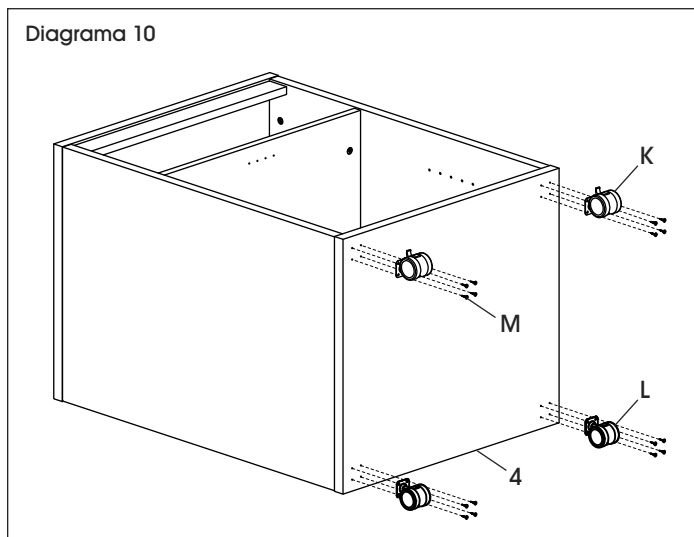

11. Instale el gancho de los broches para puerta (E) en la parte inferior de la repisa superior (6) con dos tornillos M3 x 10 mm (F). (Vea Diagrama 11)

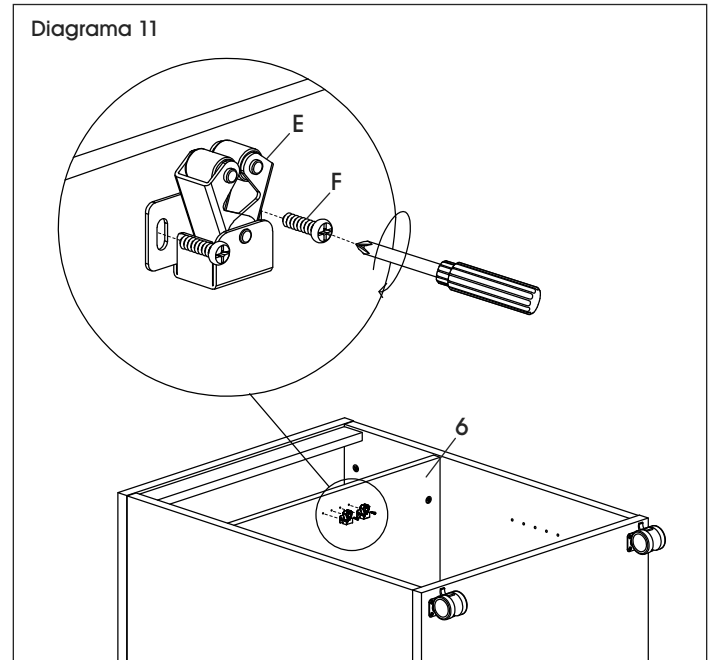

12. Instale dos taquetes para repisas (J) a la altura deseada al panel lateral. Repita la operación con el panel lateral opuesto. Inserte la repisa inferior (7). (Vea Diagrama 12)

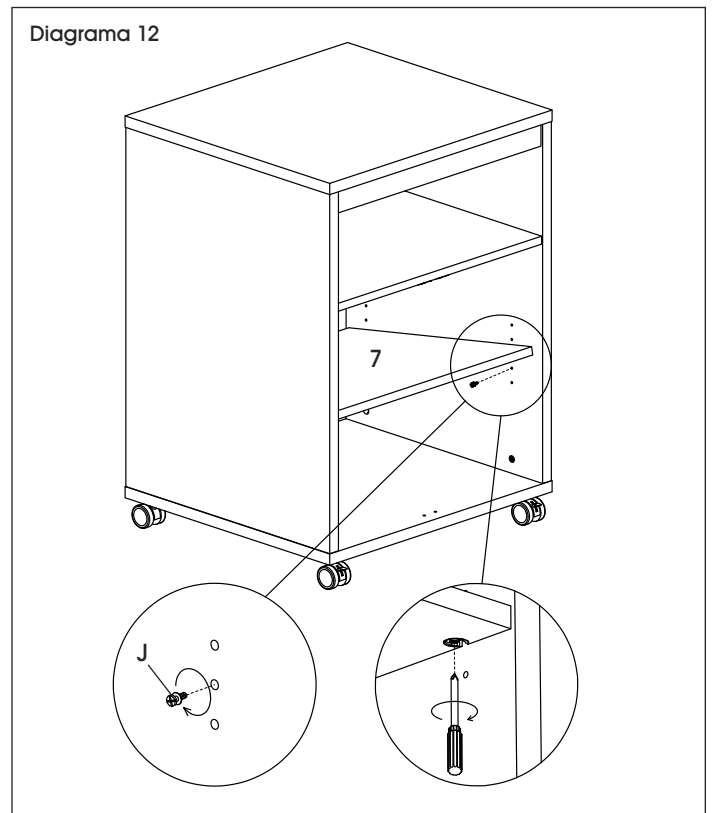

## CONTINUACIÓN DEL ENSAMBLE

13. Instale el tapón para puerta (G) en el panel inferior (4).  
Utilice un mazo de caucho de ser necesario.  
(Vea Diagrama 13)

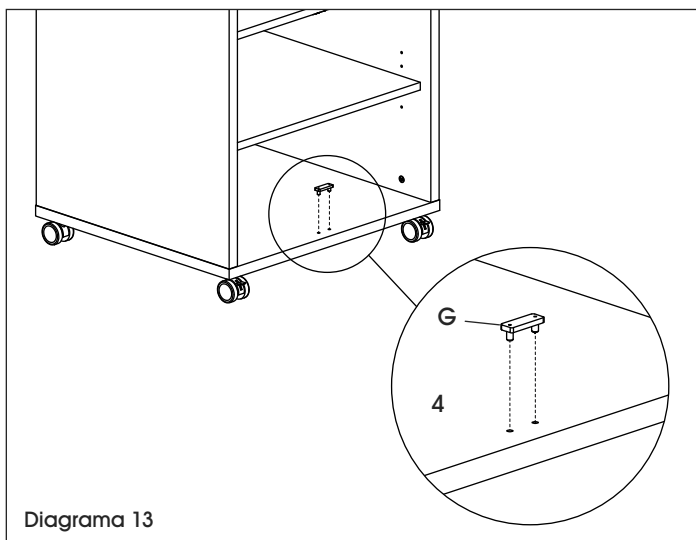

14. Instale tapas (C) en todas las tuercas minifix.  
(Vea Diagrama 14)

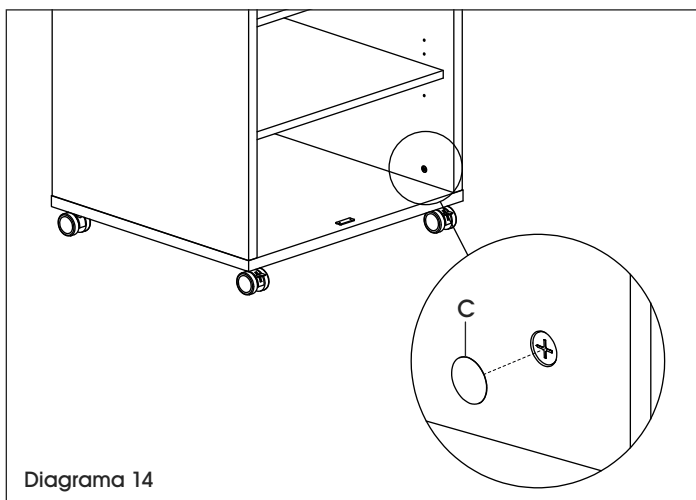

15. Instale bisagras (H) en la puerta (9) utilizando cuatro tornillos M4 x 10 mm (H). Instale el asa de la puerta (I) con dos tornillos M4 x 22 mm (I). Repita con la puerta restante. (Vea Diagrama 15)



**NOTA:** Asegúrese de que las asas apunten en el sentido correcto con la abertura del asa hacia afuera cuando las puertas estén cerradas.

Diagrama 15

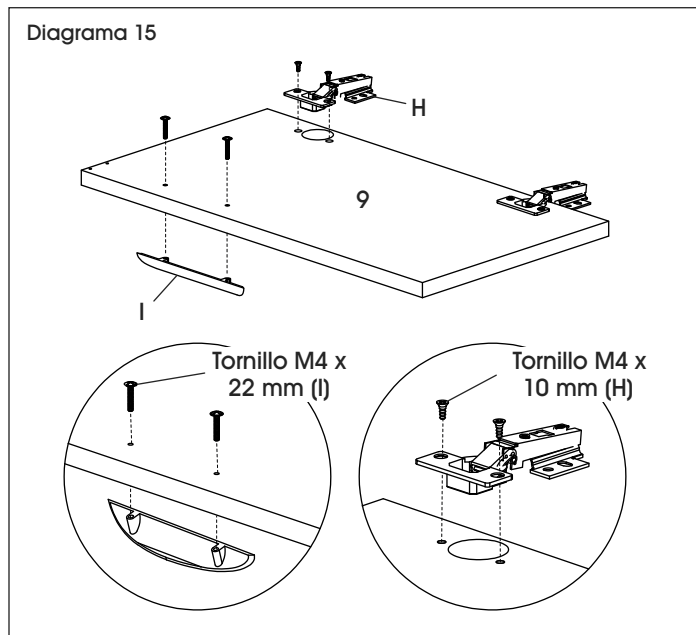

16. Instale las clavijas del broche para puerta al panel de la puerta (9) con dos tornillos M3 x 10 mm (F). Repita con la puerta restante. (Vea Diagrama 16)

Diagrama 16

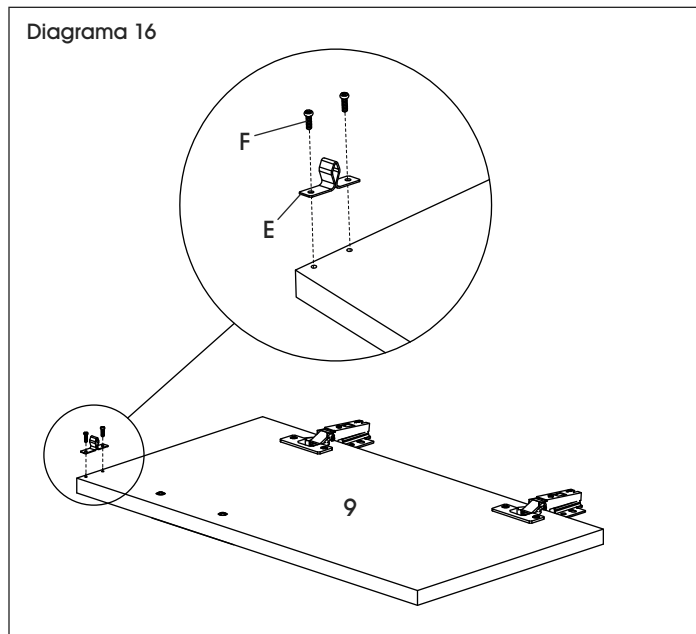

## CONTINUACIÓN DEL ENSAMBLE

17. Fije las puertas (9, 10) al carrito con ocho tornillos ST3.5 x 14 mm (M) por puerta. (Vea Diagrama 17)

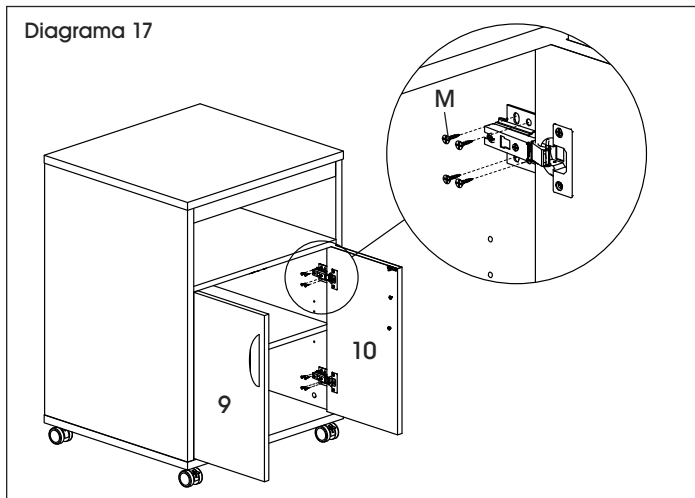

Ensamble Terminado

18. Ajuste el alto, profundidad y espacio de las puertas según sea necesario. El ensamble ya está terminado. (Vea Diagrama 18)

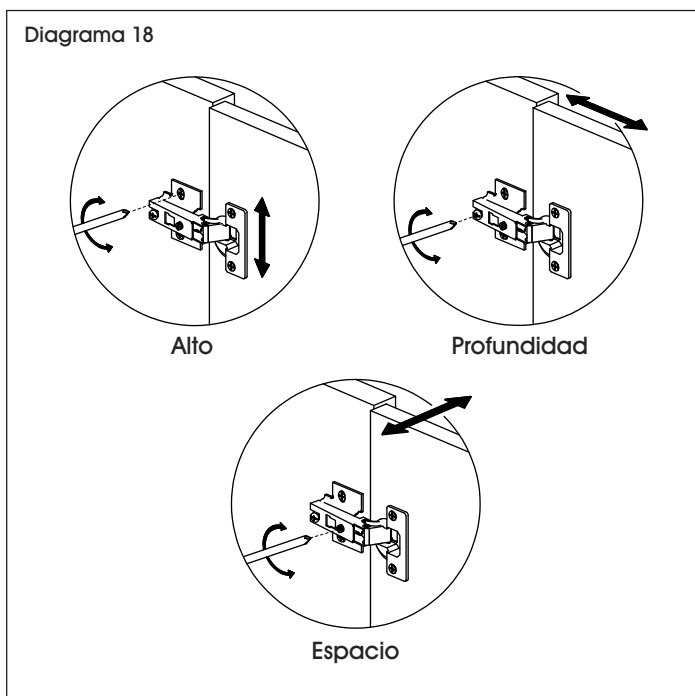

# ULINE H-11829

## COLLECTION DOWNTOWN

CHARIOT DE SALLE DE REPOS

1 800 295-5510

uline.ca

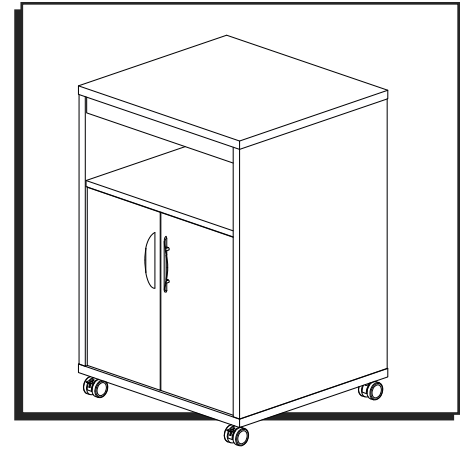

### OUTILS REQUIS

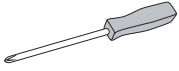

Tournevis  
cruziforme



Maillet en caoutchouc  
(optionnel)



Montage à deux  
personnes recommandé

### PIÈCES

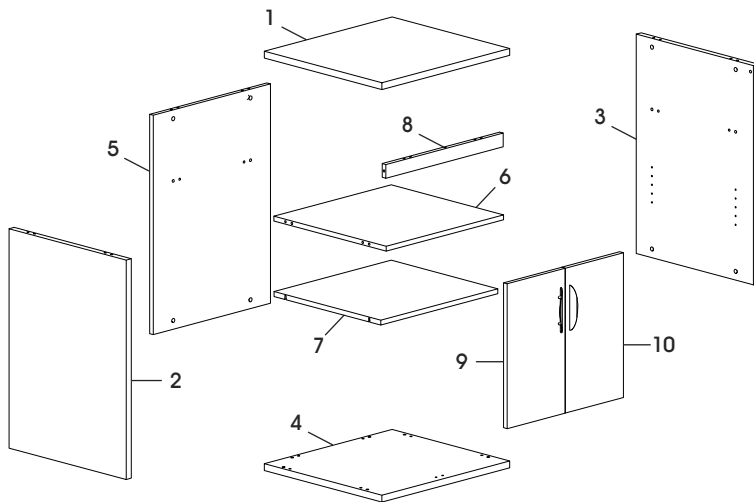

### PIÈCES

#	DESCRIPTION	QTÉ
1	Panneau supérieur	1
2	Panneau latéral gauche	1
3	Panneau latéral droit	1
4	Panneau inférieur	1
5	Panneau arrière	1
6	Tablette supérieure	1
7	Tablette inférieure	1
8	Panneau de lisse supérieure	1
9	Porte gauche	1
10	Porte droite	1

### MATÉRIEL DE FIXATION

A

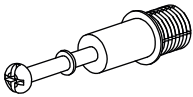

Goujon d'excentrique x 29

B



Excentrique x 29

C



Cache pour  
excentrique x 29

D

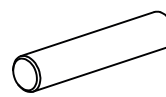

Cheville x 24

E



Fermeur de porte x 2

F

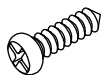

Vis M3 x 10 mm  
x 8

G

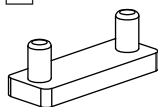

Bouchon de porte x 1

H

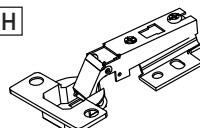

Charnière x 4

M



Vis M4 x 10 mm x 8

M

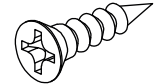

Vis ST3.5 x 14 mm  
x 16

I

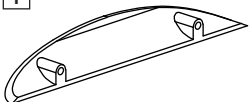

Poignée x 2

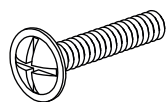

Vis M4 x 22 mm x 4

J

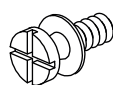

Cheville de  
tablette x 4

K

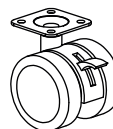

Roulette  
avec frein x 2

L

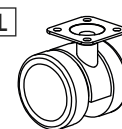

Roulette x 2

M

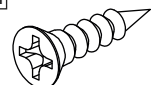

Vis ST3.5 x 14 mm  
x 16

# MONTAGE

 **REMARQUE :** Montez le meuble sur une surface lisse qui ne marque pas afin d'éviter les rayures. Vérifiez que toutes les pièces sont incluses.

 **IMPORTANT!** Tournez l'excentrique de 1/4 de tour vers la droite pour le verrouiller.

## IMPORTANT! FONCTIONNEMENT DES EXCENTRIQUES



Vérifiez que la flèche pointe vers le bord du panneau avant de l'insérer dans le trou du panneau.

 **IMPORTANT!** Les goujons d'excentrique doivent être serrés après insertion dans le panneau. Pour serrer les goujons d'excentrique, saisissez la partie inférieure du goujon d'excentrique et serrez à l'aide d'un tournevis cruciforme.

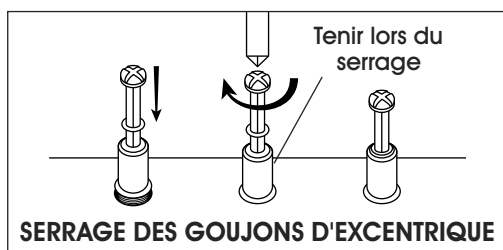

 **REMARQUE :** Utilisez le tournevis cruciforme pour serrer les excentriques, les goujons d'excentrique et les vis.

 **REMARQUE :** Une fois que les excentriques ont été serrés, les caches pour excentrique peuvent être installés pour donner un aspect fini.

1. Insérez deux goujons d'excentrique (A), deux excentriques (B) et deux chevilles (D) dans les trous correspondants du panneau arrière (5) et de la tablette supérieure (6). Fixez la tablette au panneau arrière comme l'illustre la figure ci-dessous. Serrez tous les excentriques avec le tournevis cruciforme. (Voir Figure 1)

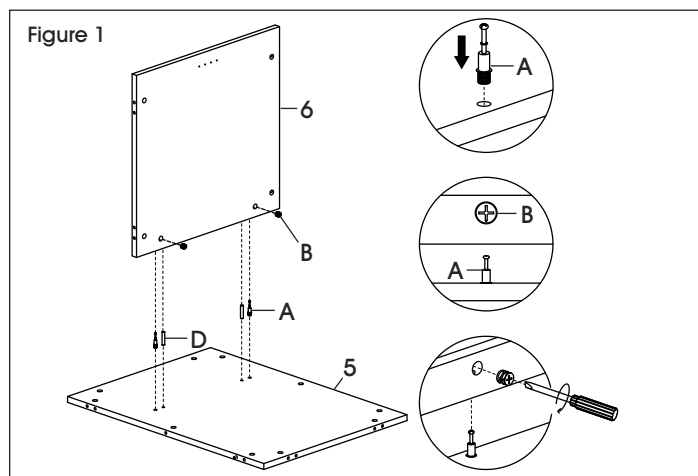

2. Installez 12 goujons d'excentrique (A) dans les trous correspondants des panneaux latéraux (2 et 3). (Voir Figure 2)

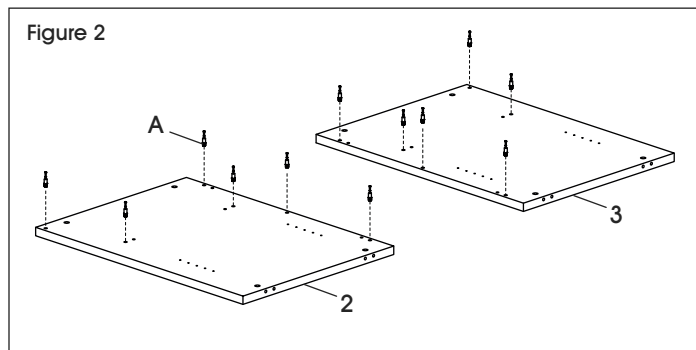

3. Fixez le panneau latéral gauche (2) au panneau arrière (5) et à la tablette supérieure (6) avec cinq excentriques (B) et quatre chevilles (D). Serrez les excentriques. (Voir Figure 3)

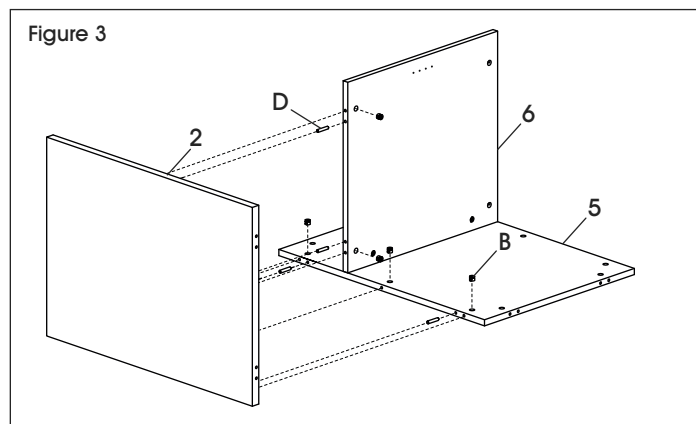

4. Fixez le panneau de lisse supérieure (8) au panneau latéral gauche (2) avec un excentrique (B). Serrez l'excentrique. (Voir Figure 4)

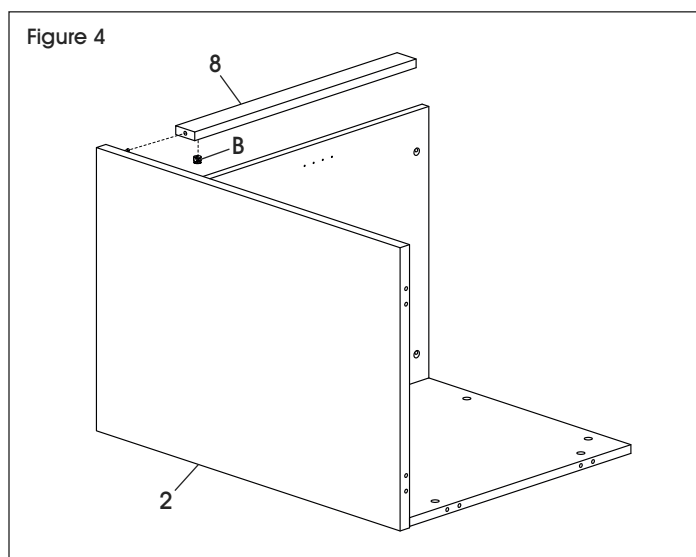

## MONTAGE SUITE

5. Fixez le panneau latéral droit (3) aux panneaux précédemment assemblés avec quatre chevilles (D) et six excentriques (B). Serrez les excentriques. (Voir Figure 5)

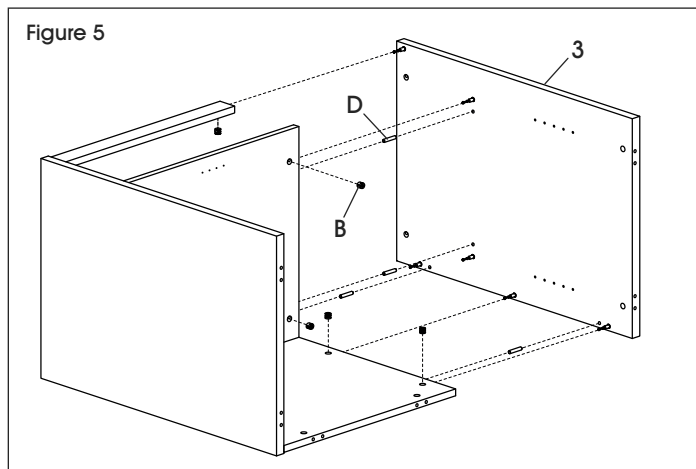

7. Installez neuf excentriques (B) et fixez le panneau supérieur (1) aux panneaux précédemment montés. Serrez les excentriques. (Voir Figure 7)

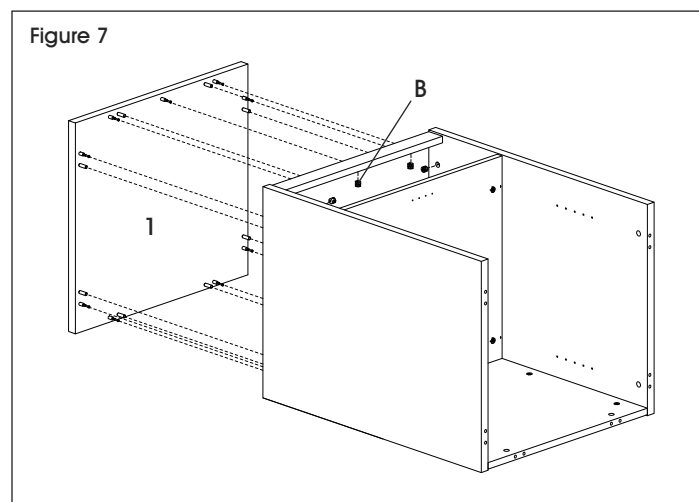

6. Installez neuf goujons d'excentrique (A) et huit chevilles (D) dans le panneau supérieur (1). (Voir Figure 6)

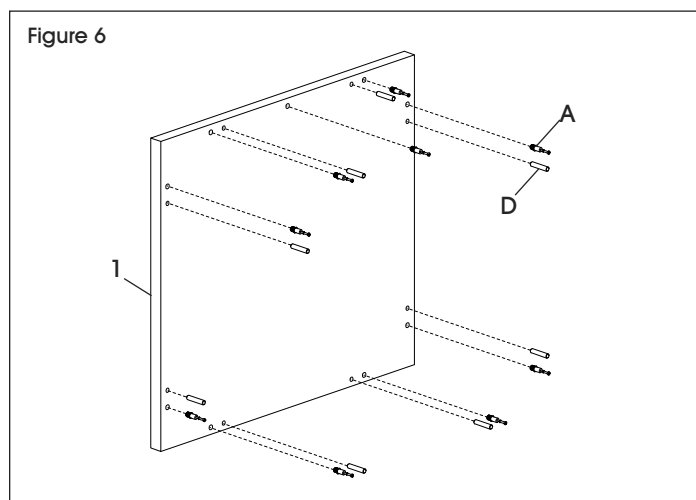

8. Installez six goujons d'excentrique (A) et six chevilles (D) dans le panneau inférieur (4). (Voir Figure 8)

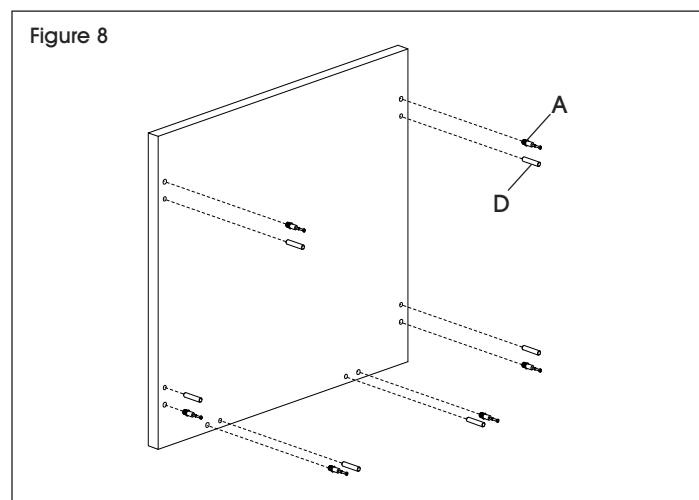

## MONTAGE SUITE

9. Installez six excentriques (B) et fixez le panneau inférieur (4) aux panneaux précédemment montés. Serrez les excentriques. (Voir Figure 9)

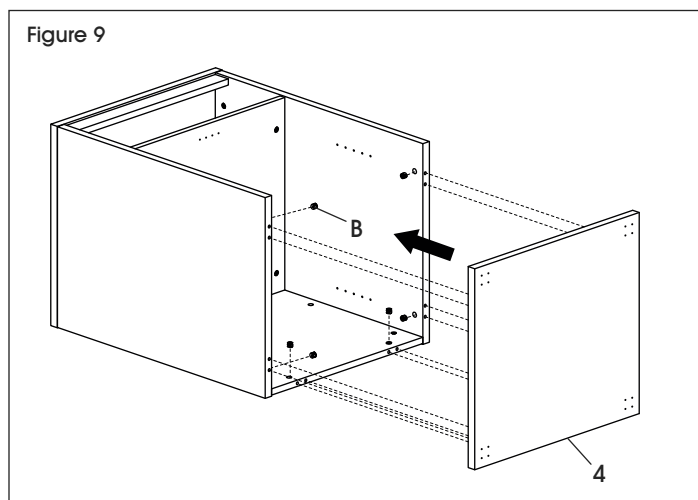

10. Fixez les roulettes avec frein (K) à l'avant du panneau inférieur (4) et les roulettes sans frein à l'arrière du panneau inférieur en utilisant quatre vis ST3.5 x 14 mm (M) par roulette. (Voir Figure 10)

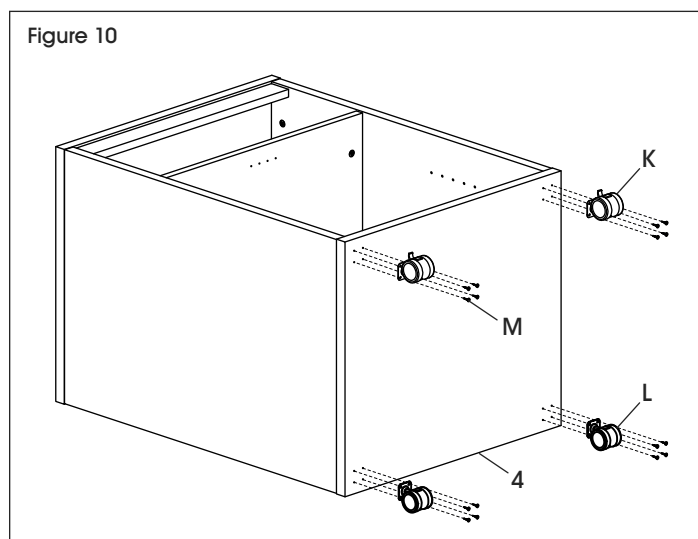

11. Installez le fermoir de porte (E) au bas de la tablette supérieure (6) avec deux vis M3 x 10 mm (F). (Voir Figure 11)

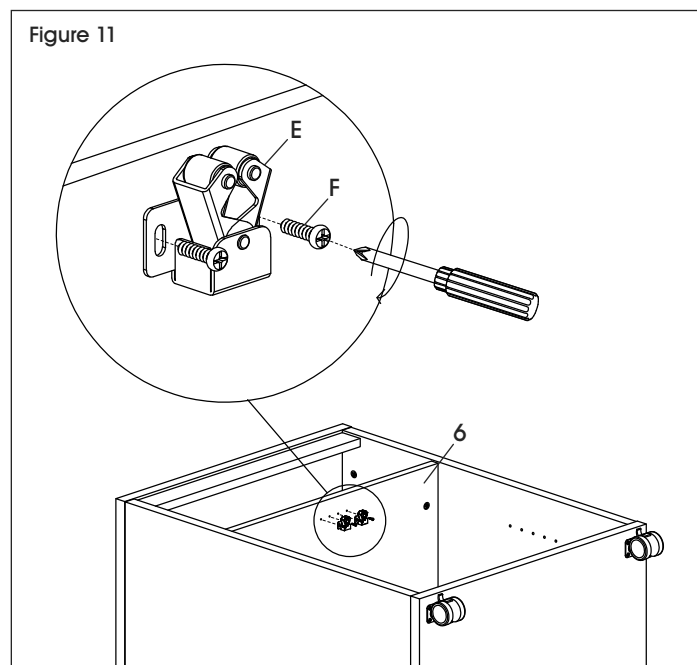

12. Installez deux chevilles de tablette (J) à la hauteur souhaitée sur le panneau latéral. Répétez la procédure pour le panneau latéral opposé. Insérez la tablette inférieure (7). (Voir Figure 12)

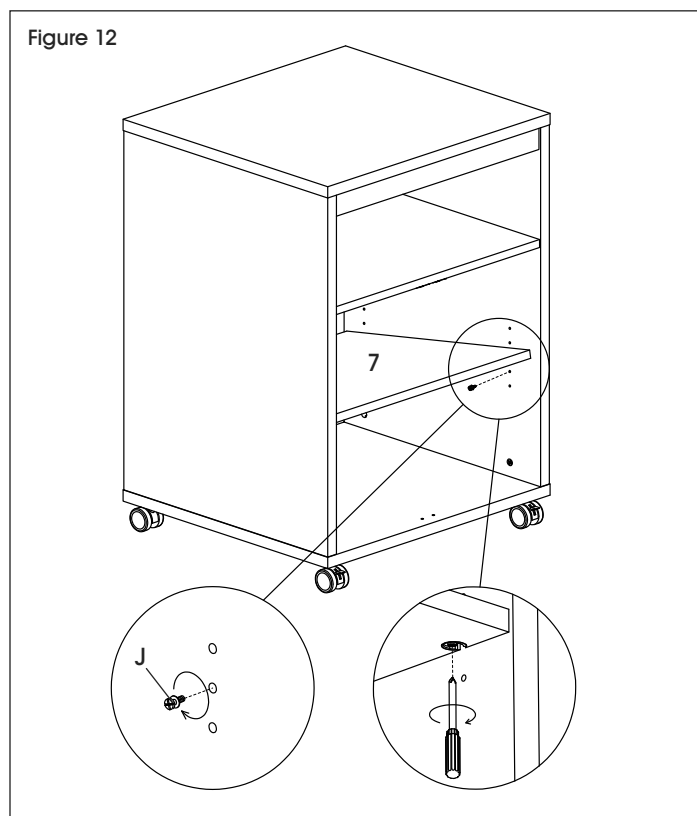



## MONTAGE SUITE

13. Installez le bouchon de porte (G) sur le panneau inférieur (4). Utilisez un maillet en caoutchouc au besoin. (Voir Figure 13)

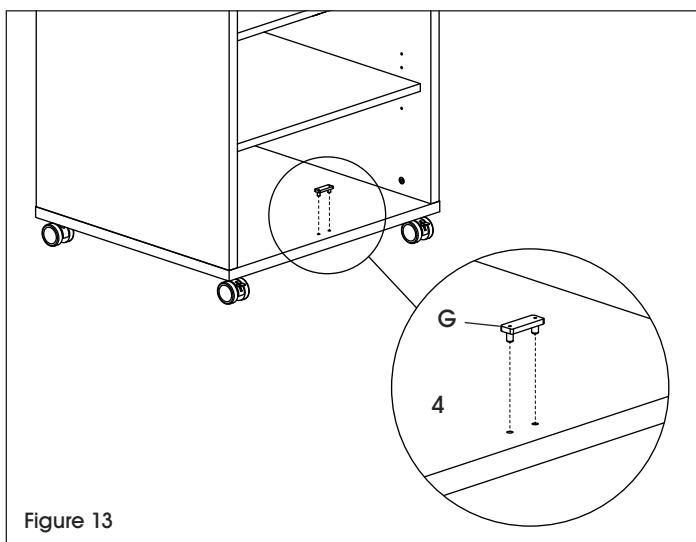

14. Installez les caches pour excentrique (C) sur tous les excentriques. (Voir Figure 14)

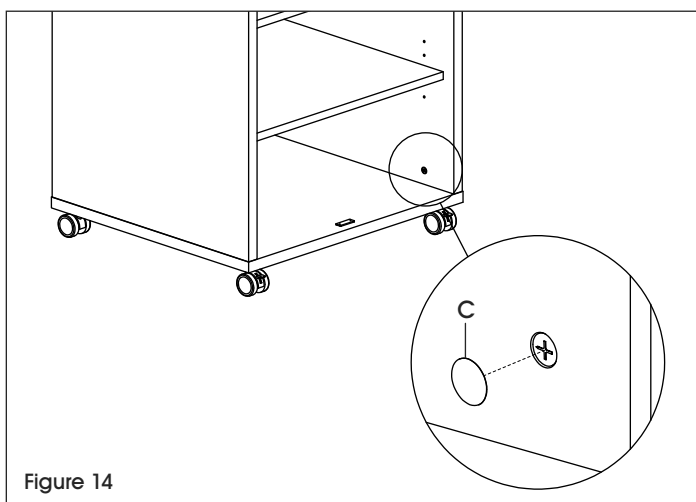

15. Installez les charnières (H) sur la porte (9) à l'aide de quatre vis M4 x 10 mm (H). Installez la poignée de porte (I) à l'aide de deux vis M4 X 22 mm (I). Répétez l'opération pour l'autre porte. (Voir Figure 15)



**REMARQUE :** Assurez-vous que les poignées soient placées du bon côté. Les ouvertures des poignées doivent être orientées vers l'extérieur lorsque les portes sont fermées.

Figure 15

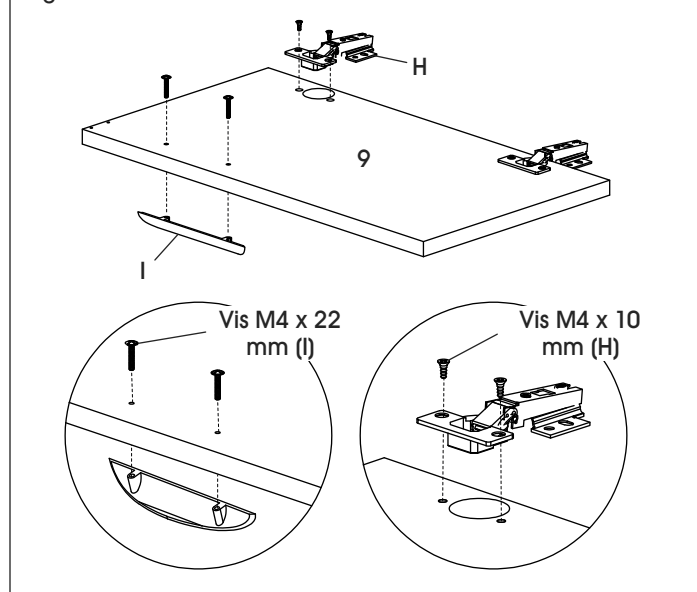

16. Installez les broches du fermoir de porte sur le panneau de porte (9) avec deux vis M3 x 10 mm (F). Répétez l'opération pour l'autre porte. (Voir Figure 16)

Figure 16

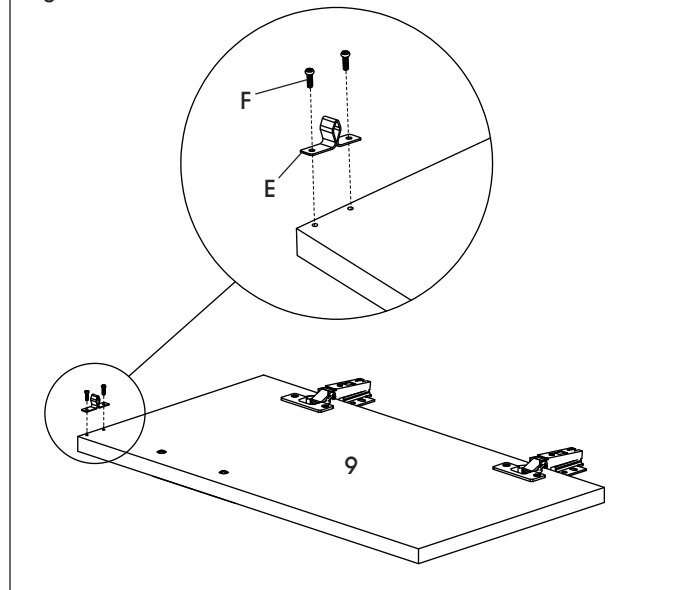

## MONTAGE SUITE

17. Fixez les portes (9 et 10) au chariot en utilisant huit vis ST3.5 x 14 mm (M) par porte. (Voir Figure 17)

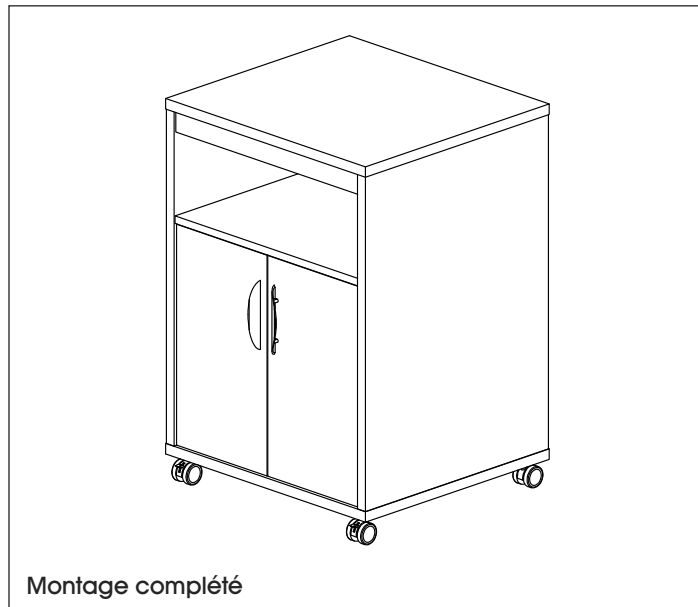
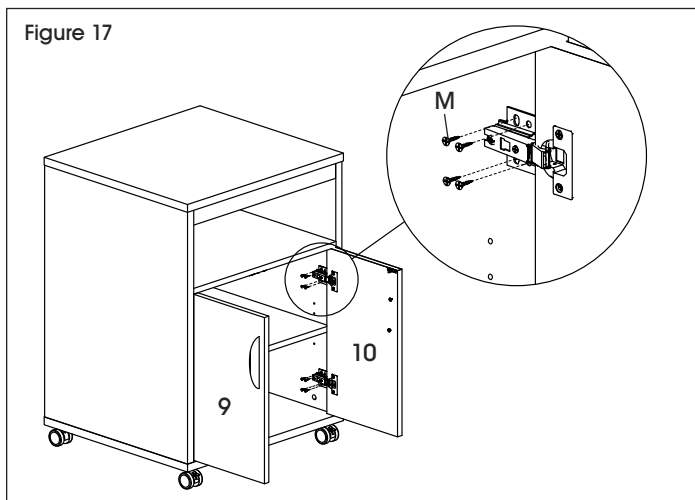

18. Réglez la hauteur, la profondeur et l'espacement des portes à votre convenance. Le montage est terminé. (Voir Figure 18)

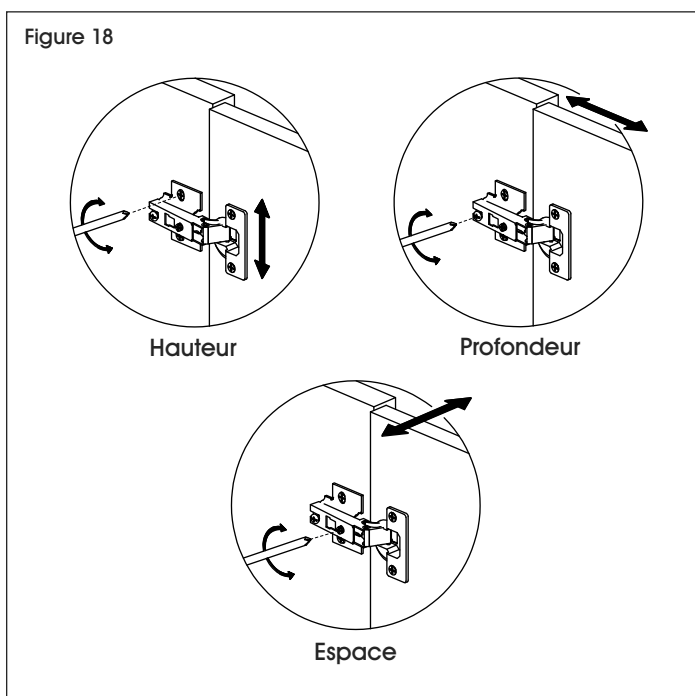

**ULINE**

1 800 295-5510  
uline.ca