

ULINE H-11844, H-11845 GAS CYLINDER CADDY

1-800-295-5510
 uline.com

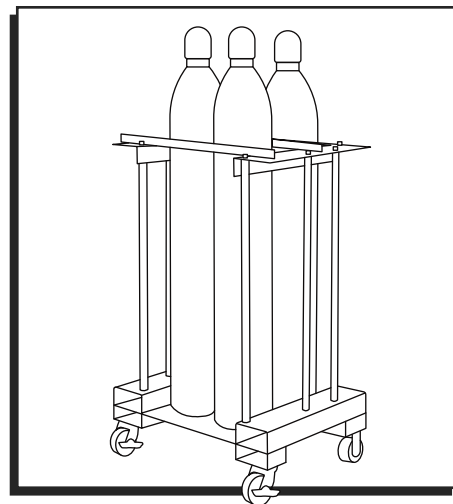

TOOLS NEEDED



Allen Wrench
(included)



Wrench
(included)



Two Person Assembly
 Recommended

PARTS

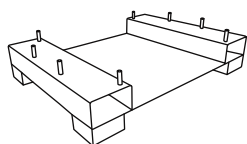

Platform Base x 1

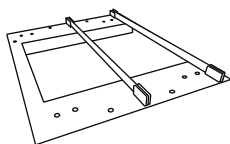

Top Plate x 1
(H-11844)

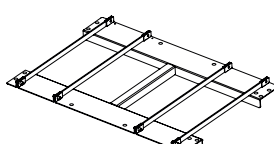

Top Plate x 1
(H-11845)

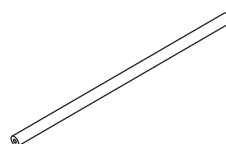

Upright x 8



Handle x 1
(H-11844)



Handle Set x 2
(H-11845)

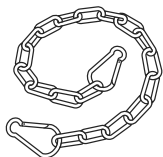

36" Snap Hook Chain x 1

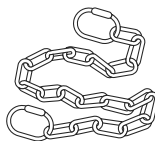

42" Forklift Chain x 1

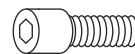

Allen Head Bolt x 12

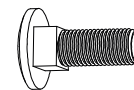

Carriage Bolt x 16

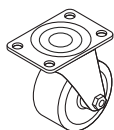

Rigid Caster x 2

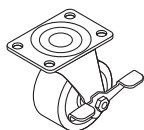

Swivel Caster with Brake x 2

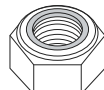

Locknut
(H-11844 x 20)
(H-11845 x 24)



Flat Washer
(H-11844 x 28)
(H-11845 x 32)



Lock Washer
(H-11844 x 12)
(H-11845 x 16)

SAFETY

- Use support bars to stabilize tanks.
- Lock support bars with safety pins.
- Distribute cylinders evenly.
- Close cylinder valves and install caps before transport.

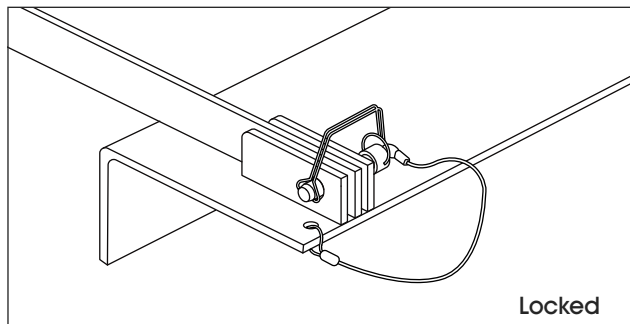
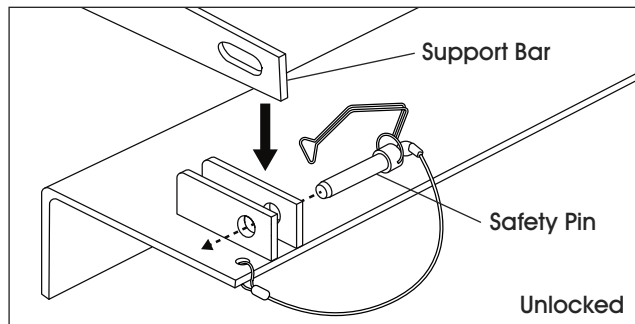

ASSEMBLY

1. Attach uprights to all pre-threaded bolts on platform base. Fully tighten. (See Figure 1)

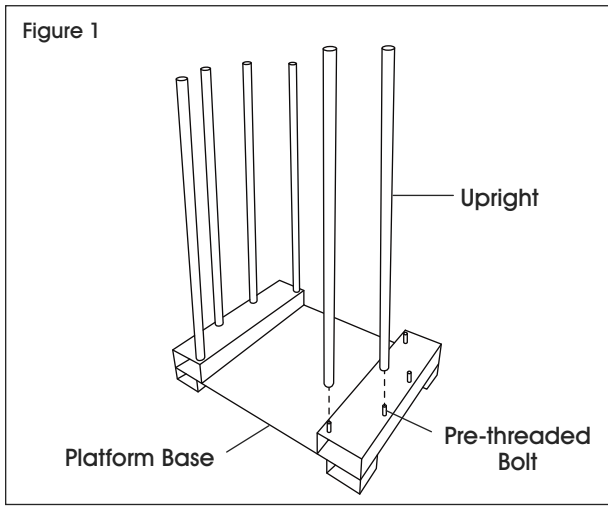

2. With second person, lift top plate onto assembled uprights. Secure with Allen head bolts, lock washers and flat washers. (See Figure 2)

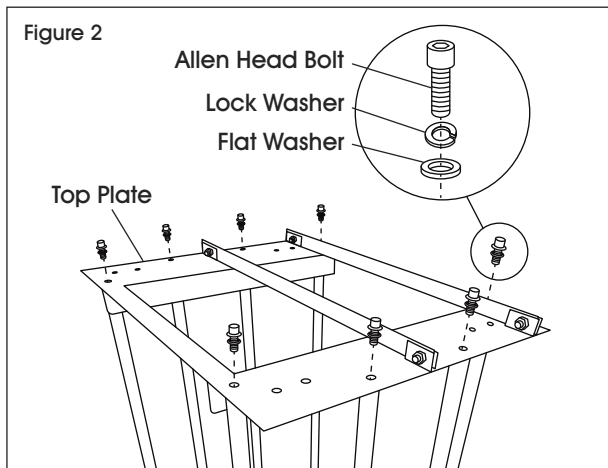

3. Tighten bolts with Allen wrench to secure.

4. Attach 36" snap hook chain to upright with D-Ring and wrap around single cylinder as needed. (See Figure 3)



NOTE: The snap hook chain secures single cylinder in caddy.

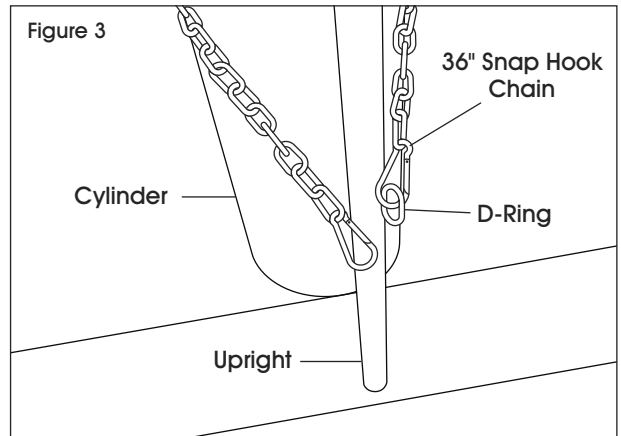

5. Attach 42" forklift chain around uprights on end of caddy. (See Figure 4)



NOTE: The forklift chain secures caddy to forklift during transport.

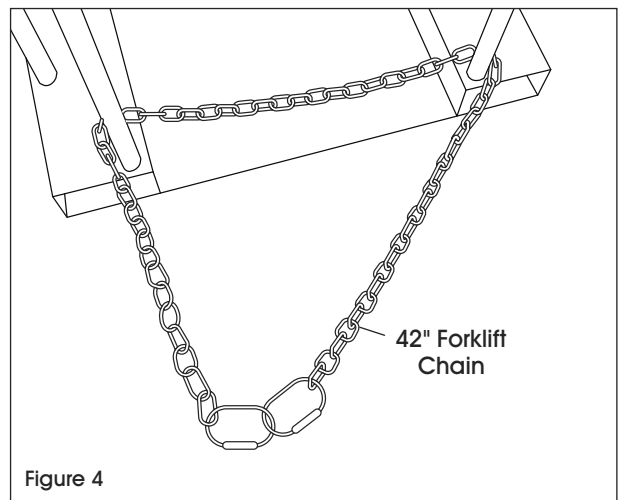

ASSEMBLY CONTINUED

OPTIONAL HANDLE INSTALLATION

1. Attach handle(s) to top plate using Allen head bolts, lock washers, flat washers and locknuts. Tighten bolts with Allen wrench to secure. (See Figures 5-6)

 **NOTE:** Handle(s) can mount to either end of caddy.

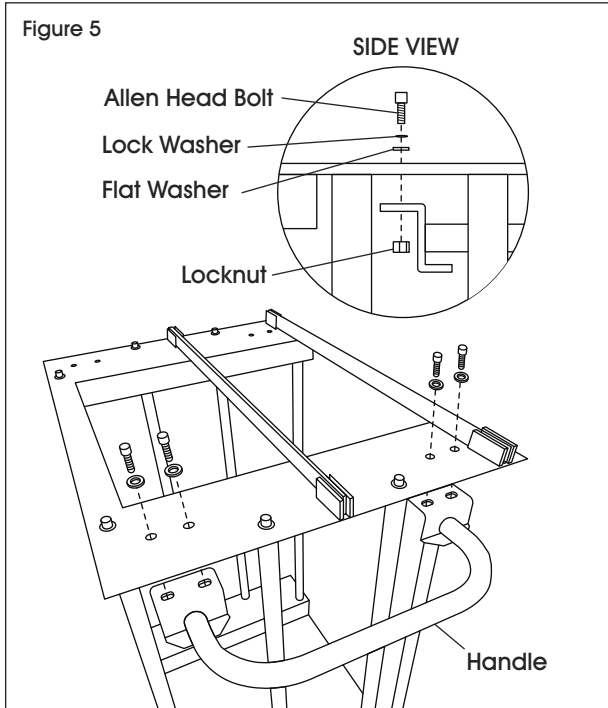

 **NOTE:** For Uline model # H-11845, install both smaller handles. (See Figure 6)

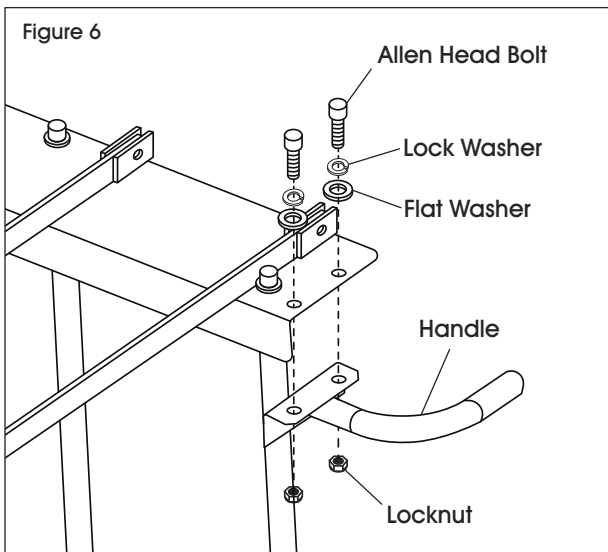

OPTIONAL CASTER INSTALLATION

1. With second person, lay caddy on its side. Install rigid and swivel casters with carriage bolts, flat washers and locknuts. (See Figure 7)

 **NOTE:** Determine rigid and swivel caster placement before installation.

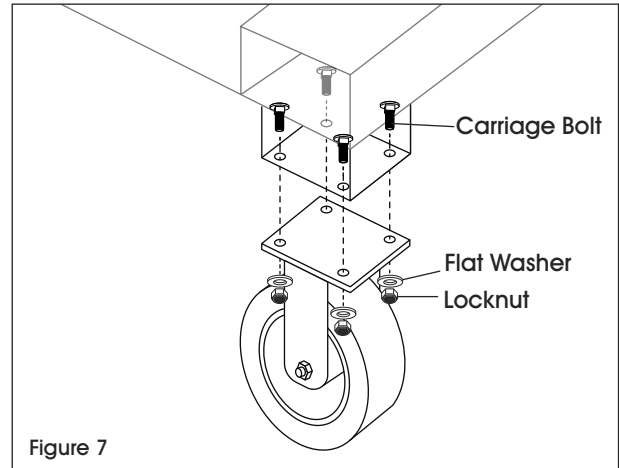

2. Tighten locknuts with wrench and lift caddy upright.

ULINE

1-800-295-5510
uline.com

ULINE H-11844, H-11845 PORTACILINDROS DE GAS

800-295-5510
uline.mx

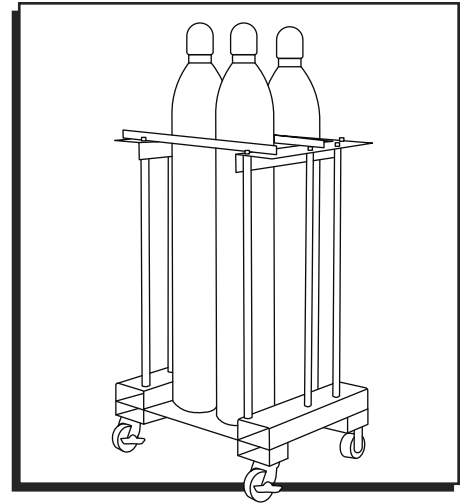

HERRAMIENTAS NECESARIAS



Llave Allen
(incluida)

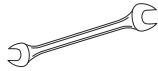

Llave
(incluida)



Se recomienda Armar
Entre Dos Personas

PARTES

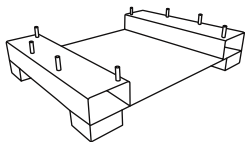

1 Base de la
Plataforma

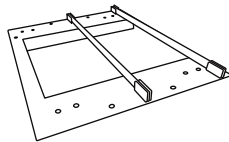

1 Placa Superior
(H-11844)

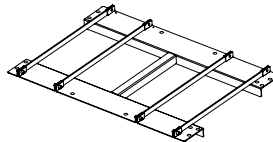

1 Placa Superior
(H-11845)

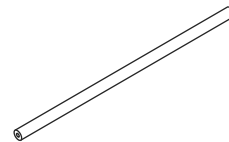

8 Postes



1 Asa Larga
(H-11844)



2 Sets de Asas
(H-11845)

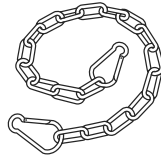

1 Cadena con
Gancho a Presión de 36"

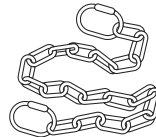

1 Cadena para
Montacargas de 42"

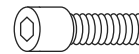

12 Pernos de
Cabeza Allen

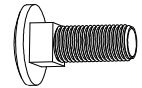

16 Pernos de
Cabeza Redonda

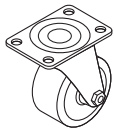

2 Ruedas Rígidas

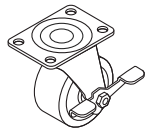

2 Ruedas Giratorias
con Freno

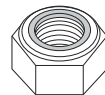

Contratuercas
(20 de H-11844)
(24 de H-11845)



Rondanas Planas
(28 de H-11844)
(32 de H-11845)

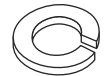

Rondanas de Seguridad
(12 de H-11844)
(16 de H-11845)

SEGURIDAD

- Utilice las barras de soporte para estabilizar los tanques.
- Asegure las barras de soporte con pasadores de seguridad.
- Distribuya los cilindros uniformemente.
- Cierre las válvulas de los cilindros e instale las tapas antes de transportar.

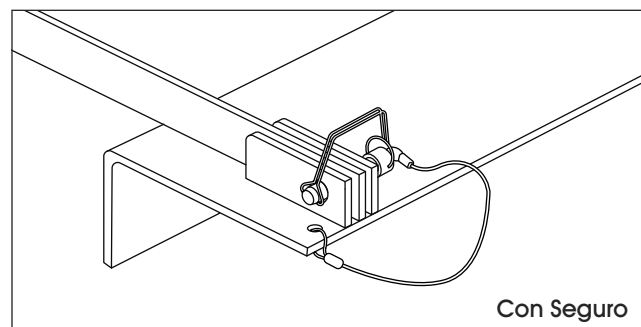
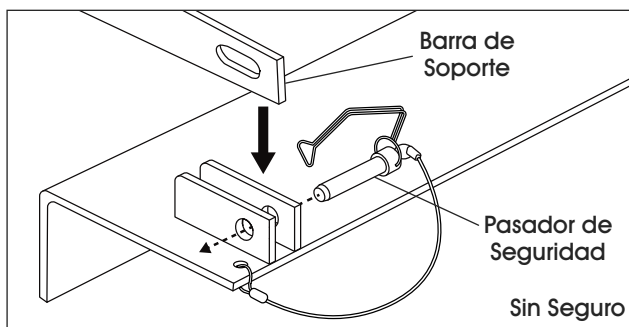

ENSAMBLE

1. Fije los postes a todos los pernos preroscados en la base de la plataforma. Apriete por completo. (Vea Diagrama 1)

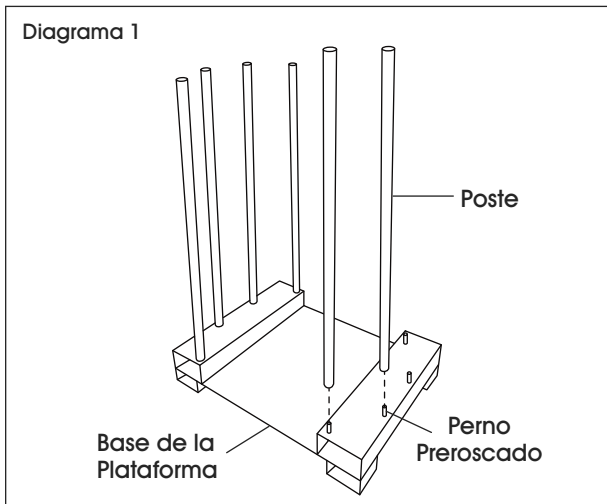

2. Con ayuda de otra persona, levante la placa superior e instálela sobre los postes. Asegure con pernos de cabeza Allen, rondanas de seguridad y rondanas planas. (Vea Diagrama 2)

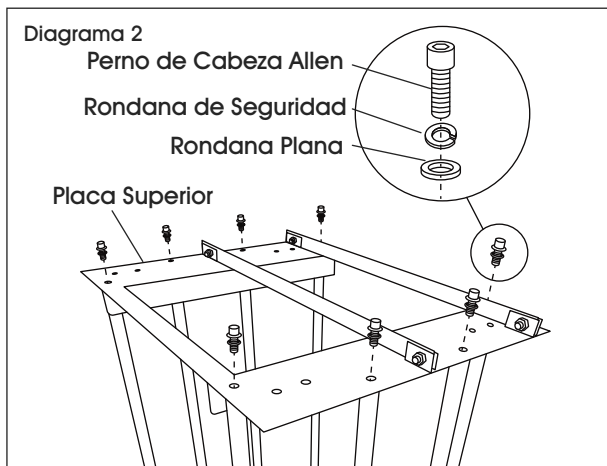

3. Apriete los pernos con la llave Allen para asegurarlos.

4. Fije la cadena de gancho a presión de 36" al poste con Anillo en D y envuélvalo alrededor de un cilindro individual según sea necesario. (Vea Diagrama 3)

 **NOTA:** La cadena de gancho a presión asegura el cilindro individual en el portacilindros.

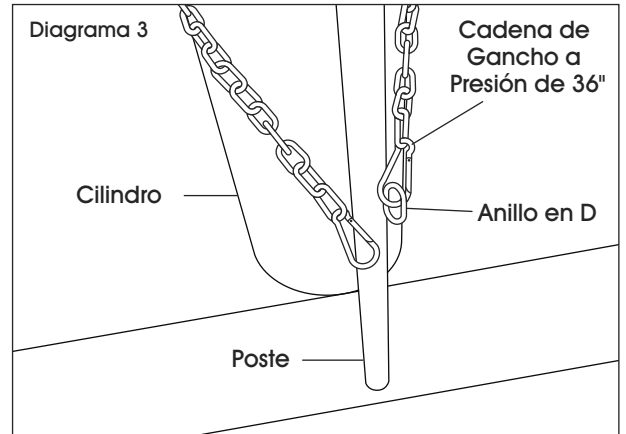

5. Fije la cadena para montacargas de 42" alrededor de los postes del extremo del portacilindros. (Vea Diagrama 4)

 **NOTA:** La cadena para montacargas asegura el portacilindros al montacargas durante el transporte.

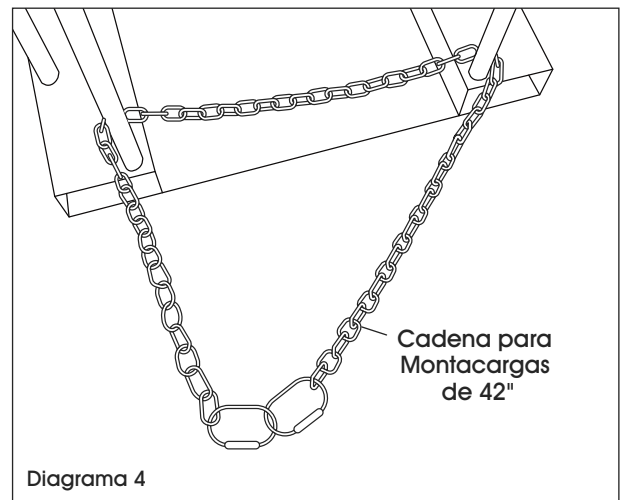

CONTINUACIÓN DEL ENSAMBLE

INSTALACIÓN OPCIONAL DEL ASA

1. Fije el(las) asa(s) a la placa superior utilizando pernos de cabeza Allen, rondanas de seguridad, rondanas planas y contratuercas. Apriete los pernos con la llave Allen para asegurarlos. (Vea Diagramas 5-6)

 **NOTA:** El(las) asa(s) se pueden instalar en cualquier extremo del portacilindros.

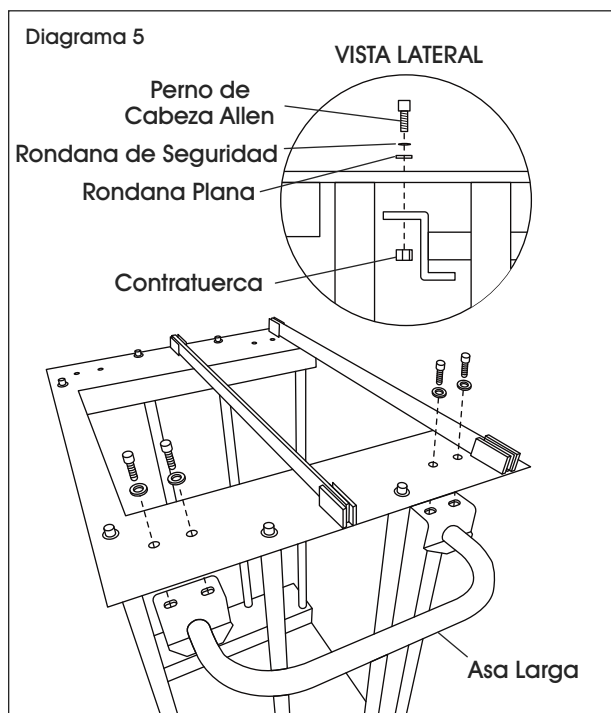

 **NOTA:** Para el modelo Uline # H-11845, instale ambas asas cortas. (Vea Diagrama 6)

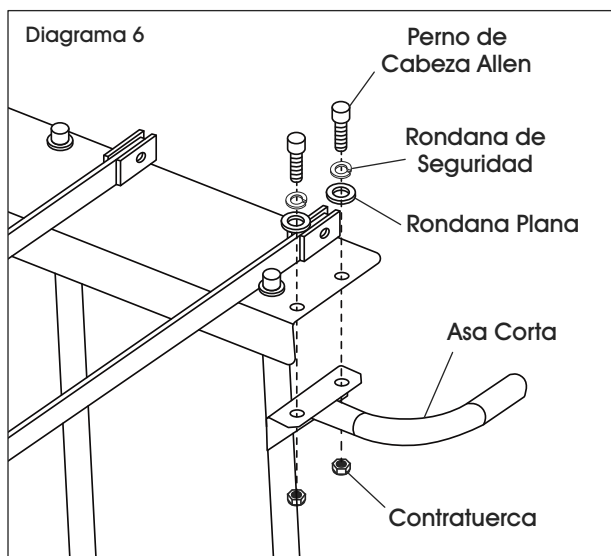

INSTALACIÓN OPCIONAL DE LAS RUEDAS

1. Con ayuda de otra persona, coloque el portacilindros de lado. Instale las ruedas rígidas y giratorias con pernos de cabeza redonda, rondanas planas y contratuercas. (Vea Diagrama 7)

 **NOTA:** Determine la colocación de las ruedas rígidas y giratorias antes de instalar.

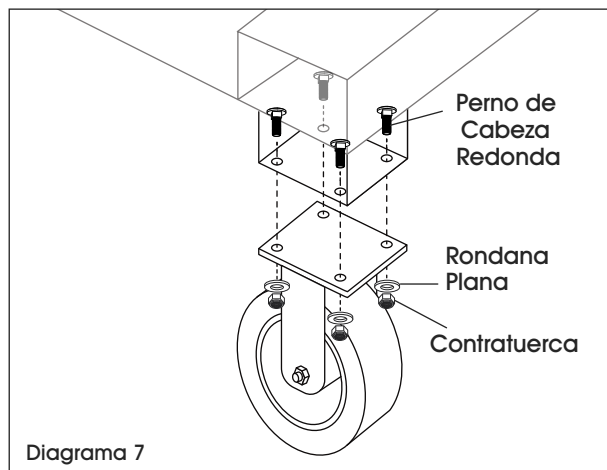

2. Apriete las contratuercas con una llave y coloque el portacilindros de pie.

ULINE

800-295-5510
uline.mx

ULINE H-11844, H-11845

CHARIOT POUR BOUTEILLES À GAZ

1 800 295-5510
uline.ca

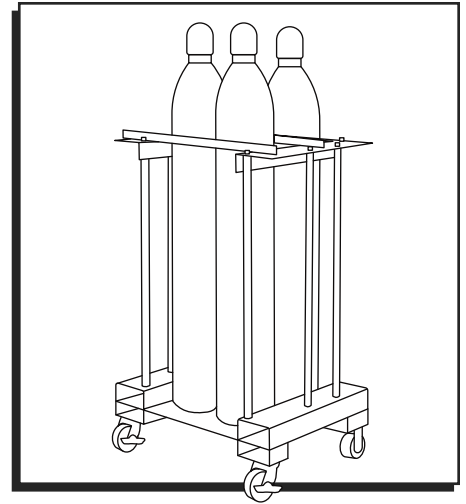

OUTILS REQUIS



Clé Allen
(inclus)



Clé
(inclus)



Montage à deux
personnes recommandé

PIÈCES

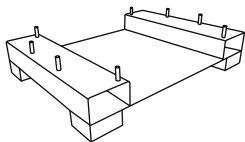

Base de la
plateforme x 1

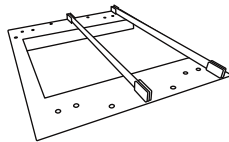

Plaque supérieure x 1
(H-11844)

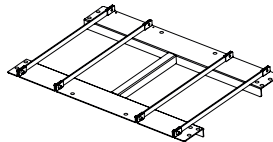

Plaque supérieure x 1
(H-11845)

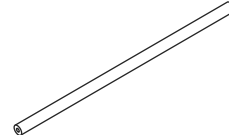

Montant x 8



Poignée x 1
(H-11844)



Ensemble de poignée x 2
(H-11845)

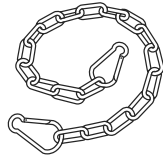

Chaîne à mousqueton
de 36 po x 1

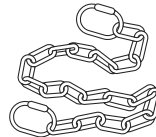

Chaîne de chariot
élévateur de 42 po x 1

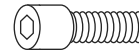

Boulon Allen x 12

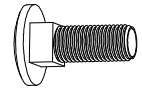

Boulon de
carrosserie x 16

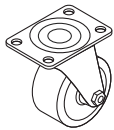

Roulette fixe x 2

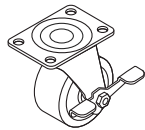

Roulette pivotante
avec frein x 2

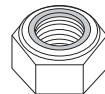

Écrou de blocage
(H-11844 x 20)
(H-11845 x 24)



Rondelle plate
(H-11844 x 28)
(H-11845 x 32)

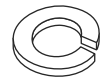

Rondelle de blocage
(H-11844 x 12)
(H-11845 x 16)

SÉCURITÉ

- Utilisez les barres de support pour stabiliser les réservoirs.
- Verrouillez les barres de support avec des goupilles de sécurité.
- Répartissez uniformément les bouteilles.
- Fermez les soupapes des bouteilles et installez les capuchons avant le transport.

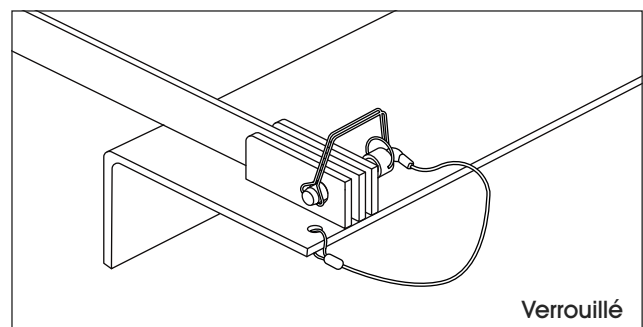
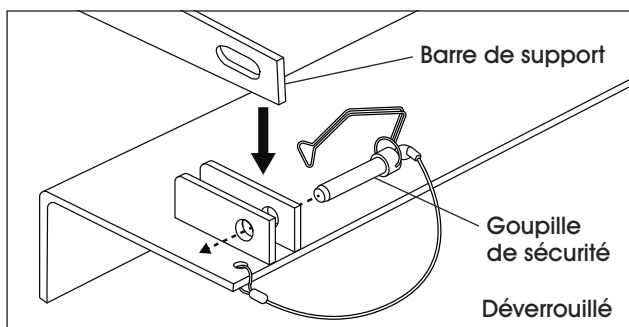

MONTAGE

1. Fixez les montants sur les boulons préfiletés dans la base de la plateforme. Serrez-les fermement. (Voir Figure 1)

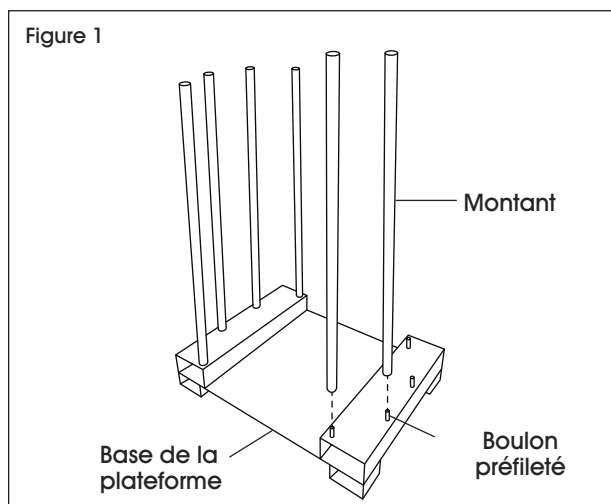

2. À deux, placez la plaque supérieure sur les montants fixés. Fixez la plaque avec des boulons Allen, des rondelles de blocage et des rondelles plates. (Voir Figure 2)

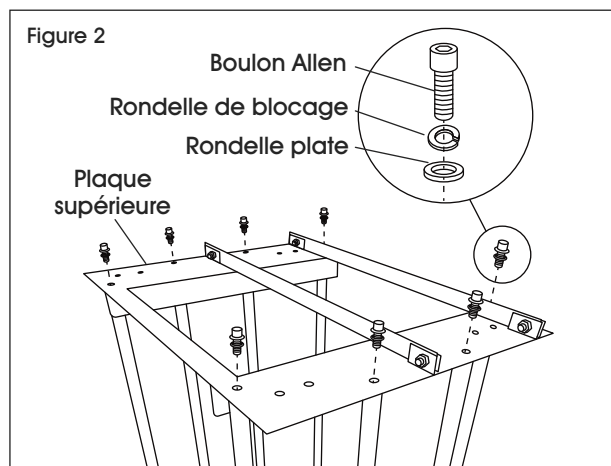

3. Serrez les boulons avec la clé Allen pour fixer le tout.

4. Accrochez la chaîne à mousqueton de 36 po au montant avec un anneau en D et enroulez la chaîne autour d'une bouteille à gaz individuelle au besoin. (Voir Figure 3)

 **REMARQUE :** La chaîne à mousqueton maintient la bouteille individuelle en place dans le chariot.

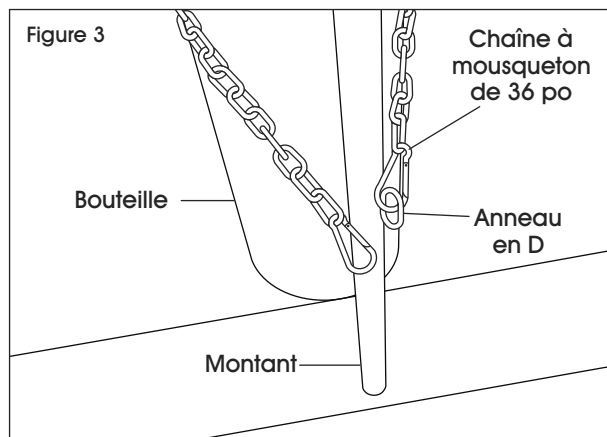

5. Accrochez la chaîne de chariot élévateur de 42 po autour des montants situés à l'extrémité du chariot. (Voir Figure 4)

 **REMARQUE :** La chaîne de chariot élévateur maintient le chariot pour bouteilles à gaz en place pendant le transport.

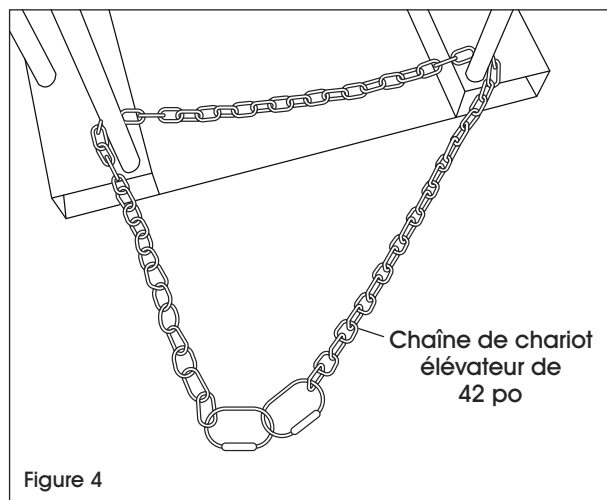



MONTAGE SUITE

INSTALLATION DE LA POIGNÉE (OPTIONNEL)

1. Fixez la/les poignée(s) à la plaque supérieure avec des boulons Allen, des rondelles de blocage, des rondelles plates et des écrous de blocage. Serrez les boulons avec la clé Allen pour fixer le tout. (Voir Figures 5 et 6)

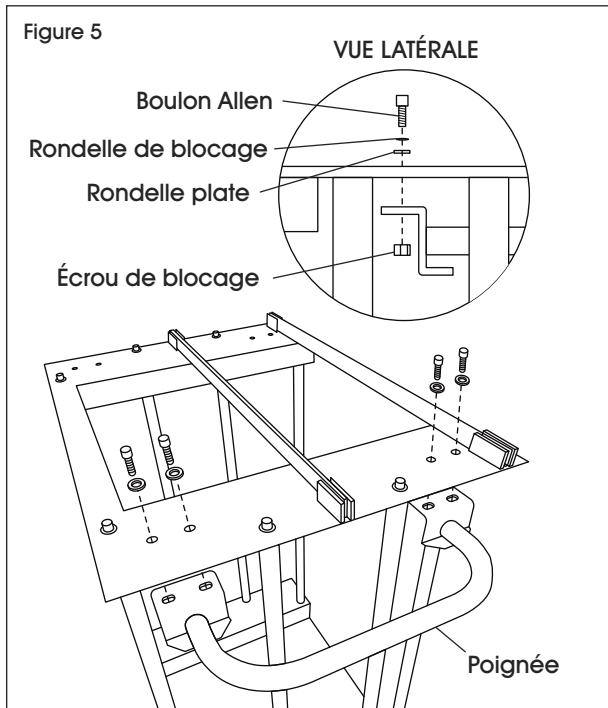
 **REMARQUE :** La/les poignée(s) peuvent être fixées à l'une ou l'autre des extrémités du chariot.



 **REMARQUE :** Pour le numéro de modèle Uline H-11845, installez les deux petites poignées. (Voir Figure 6)

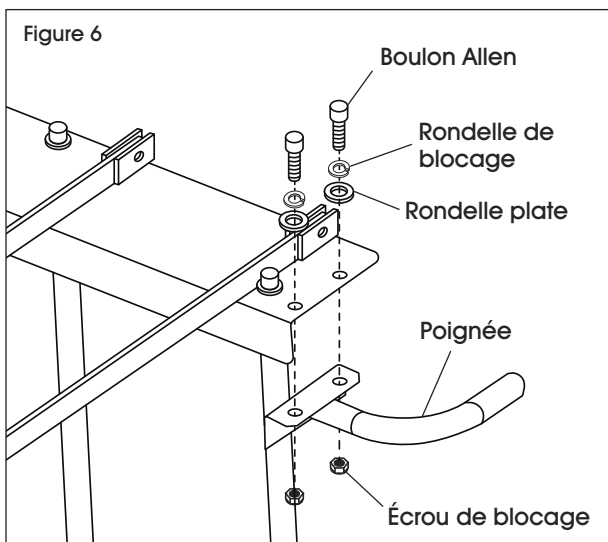

INSTALLATION DES ROULETTES (OPTIONNEL)

1. À deux, déposez le chariot à l'horizontale. Installez les roulettes fixes et pivotantes avec des boulons de carrosserie, des rondelles plates et des écrous de blocage. (Voir Figure 7)

 **REMARQUE :** Décidez de l'agencement des roulettes fixes et pivotantes avant de les installer.

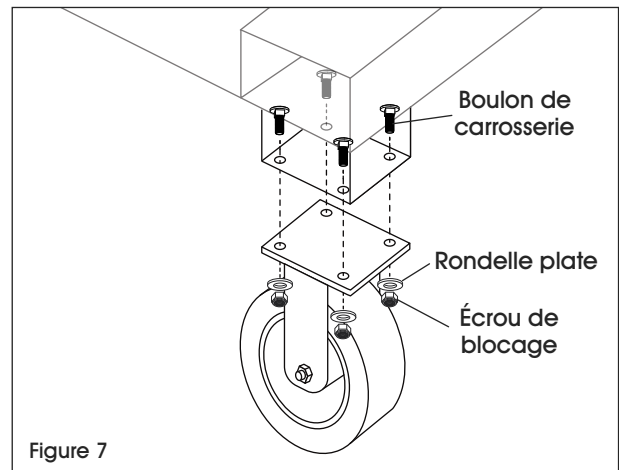

2. Serrez les écrous de blocage à l'aide de la clé, puis remettez le chariot à l'endroit.