

**TOOL NEEDED**

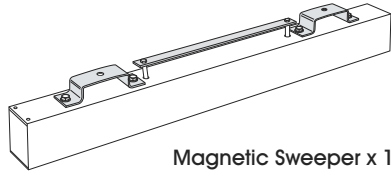

Forklift

**PARTS**



Magnetic Sweeper x 1

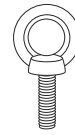

Eyebolt x 2

**INSTRUCTIONS**

**ASSEMBLY**

Screw eyebolts partially into fork pockets. Ensure fork pockets are fully open. (See Figures 1-2)

**USAGE**

1. Slide fork tines into the pockets by driving the forklift into position or manually lifting the magnet onto the tines. (See Figure 3)

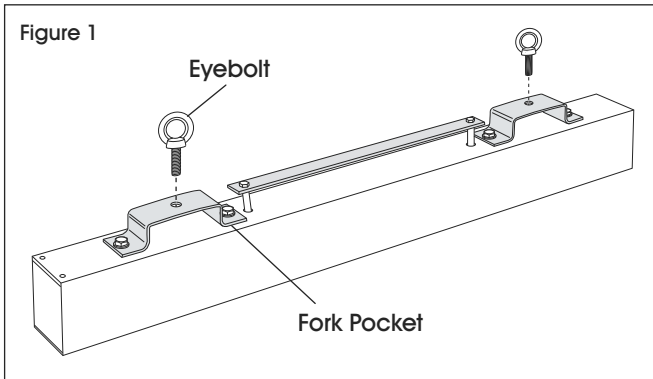

Figure 1

Eyebolt

Fork Pocket

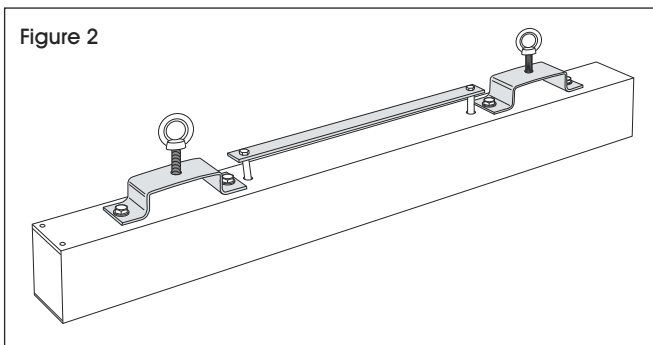

Figure 2

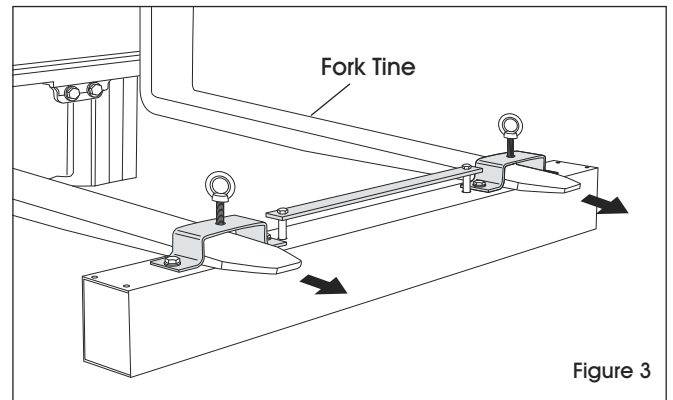
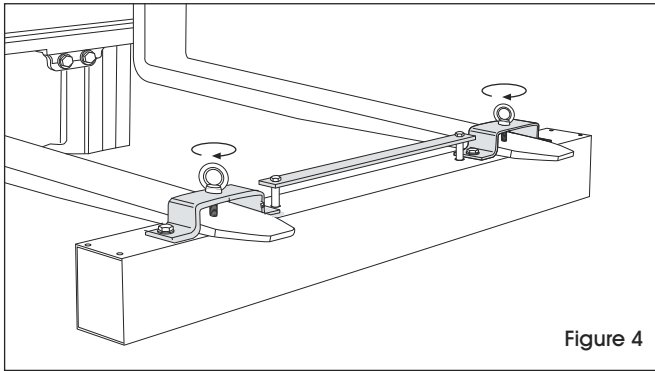

Figure 3

## INSTRUCTIONS CONTINUED

2. Tighten eyebolts once magnet is centered and in the desired position. (See Figure 4)



3. Drive forklift so magnetic sweeper is over metal debris to pick up. (See Figures 5-6)

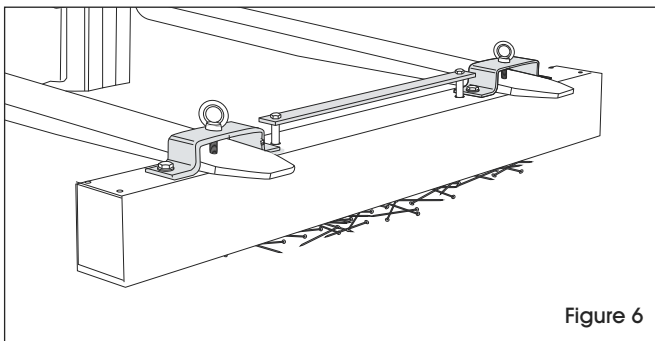
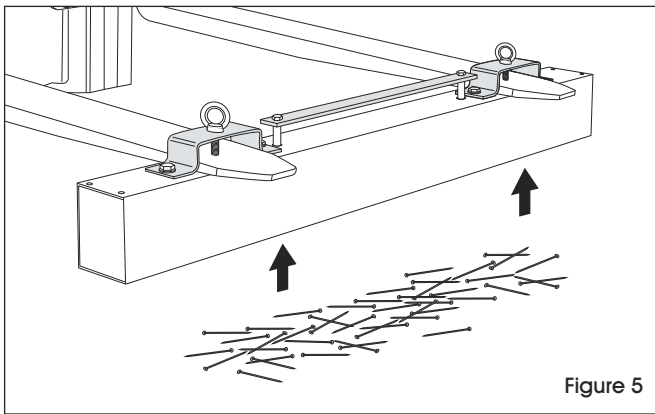

4. Lift release bar to release collected debris from the magnet. (See Figure 7)

