

ULINE H-1199 MAIL CART

1-800-295-5510
uline.com

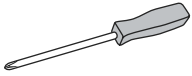

TOOLS NEEDED



Phillips Screwdriver



Adjustable Wrench



Rubber Mallet

PARTS



NOTE: Hardware comes preassembled on the cart. Additional replacement hardware also included.

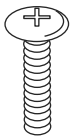

2" Bolt x 4

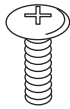

1 1/4" Bolt x 4



3/8" Bolt x 4



3/16" Nut x 4



1/4" Nut x 8

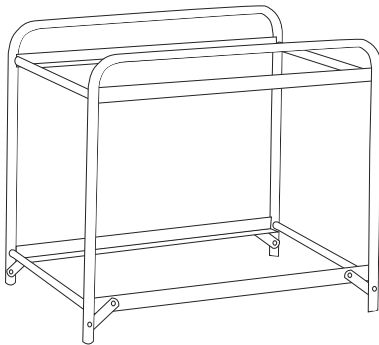

Cart Assembly x 1

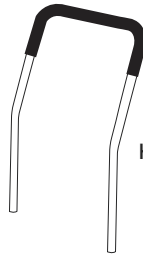

Handle x 1



Guide Rod x 3



Upper Basket x 1

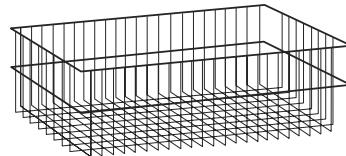

Lower Basket x 1



Donut Bumper x 2

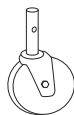

4" Swivel Caster x 2



4" Rigid Caster x 2

ASSEMBLY

GETTING STARTED

1. Remove all components from box.
2. Set cart assembly upside down (with open ends pointing upward).

INSTALLING FRONT CASTERS

Locate front of cart assembly.

 **NOTE:** The front of the cart assembly is the end with no handle mounting holes. (See Figure 2)

1. Remove bolt from flat brace on the cart assembly tube side. Loosen other bolt if necessary. (See Figure 1)
2. Slide donut bumper onto cart assembly tube.
3. Insert 4" swivel caster into cart assembly tube.

 **NOTE:** Tap casters into place with rubber mallet if necessary.

4. Insert bolt through holes in flat brace, caster and cart assembly tube. Fasten with nut. Tighten securely.
5. Repeat steps to install remaining swivel caster to other side.

INSTALLING REAR CASTERS

1. Remove bolt from flat brace on the cart assembly tube. Loosen other bolt if necessary.
2. Insert 4" rigid caster into cart assembly tube.

 **NOTE:** Tap casters into place with rubber mallet if necessary.

3. Insert bolt through holes in flat brace, caster and cart assembly tube. Fasten with nut. Tighten securely.
4. Repeat steps to install remaining rigid caster to other side.

INSTALL REMAINING PARTS

1. Turn cart upright and attach handle to rear of mail cart on both sides using bolts and nuts. (See Figure 2)
2. Place baskets onto the cart assembly.
3. Install guide rods on upper basket. (See Figure 3)

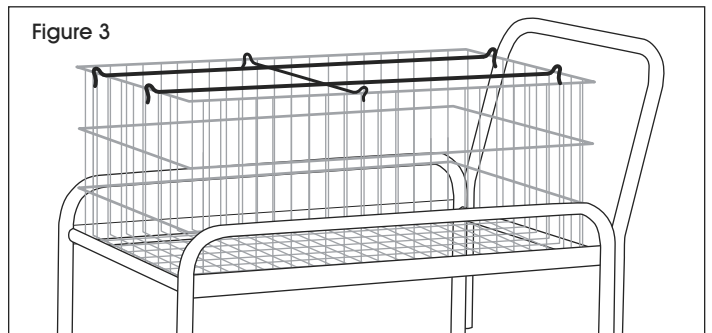
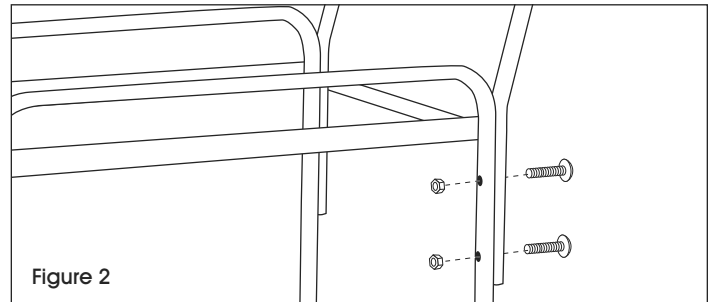
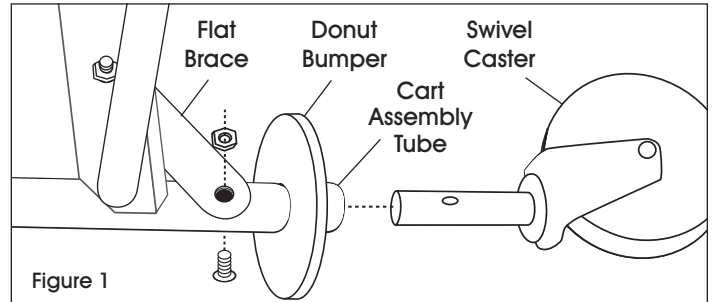

ULINE

1-800-295-5510
uline.com

ULINE H-1199

CARRITO PARA CORREO

800-295-5510
uline.mx



HERRAMIENTAS NECESARIAS

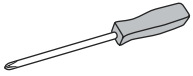

Desarmador de Cruz



Llave Ajustable



Mazo de Caucho

PARTES



NOTA: La tornillería viene preensamblada en el carrito. También se incluye tornillería de repuesto adicional.

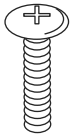

4 Pernos de 2"

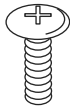

4 Pernos de 1/4"



4 Pernos de 3/8"



4 Tuercas de 3/16"



8 Tuercas de 1/4"

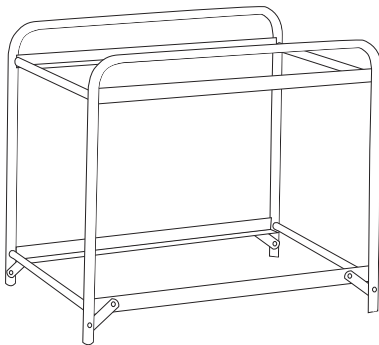

1 Ensemble del Carrito

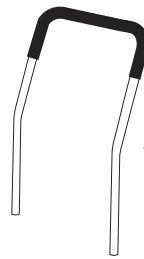

1 Asa



3 Varillas Guía

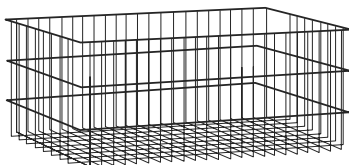

1 Canasta Superior

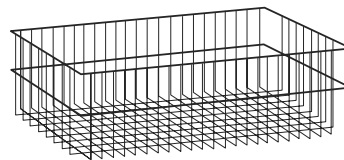

1 Canasta Inferior



2 Topes en Forma de Rosca

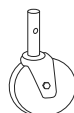

2 Ruedas Giratorias de 4"



2 Ruedas Fijas de 4"

INICIO

1. Saque todos los componentes de la caja.
2. Coloque el ensamble del carrito boca abajo (con los extremos abiertos apuntando hacia arriba).

COLOCAR LAS RUEDAS DELANTERAS

Ubique la parte delantera del ensamble del carrito.

 **Nota:** la parte delantera del ensamble del carrito es el extremo que no tiene orificios para la instalación del asa. (Vea Diagrama 2)

1. Quite el perno del soporte plano en el lateral del tubo del ensamble del carrito. Afloje el otro perno en caso de ser necesario. (Vea Diagrama 1)
2. Deslice el tope en forma de rosca para insertarlo en el tubo del ensamble del carrito.
3. Inserte la rueda giratoria de 4" en el tubo del ensamble del carrito.

 **NOTA:** Golpee las ruedas para insertarlas en su lugar con un mazo de caucho de ser necesario.

4. Inserte pernos a través de los orificios del soporte plano, la rueda y el tubo del ensamble del carrito. Fíjelos con tuercas. Apriételes bien.
5. Repita los pasos para colocar la rueda giratoria restante en el otro lado.

COLOCAR LAS RUEDAS TRASERAS

1. Quite el perno del soporte plano en el tubo del ensamble del carrito. Afloje el otro perno en caso de ser necesario.
2. Inserte la rueda fija de 4" en el tubo del ensamble del carrito.

 **NOTA:** Golpee las ruedas para insertarlas en su lugar con un mazo de caucho de ser necesario.

3. Inserte pernos a través de los orificios del soporte plano, la rueda y el tubo del ensamble del carrito. Fíjelos con tuercas. Apriételes bien.
4. Repita los pasos para colocar la rueda fija restante en el otro lado.

COLOCAR LAS PARTES RESTANTES

1. Voltee el carrito para colocarlo en posición vertical y fije el asa a la parte posterior del carrito para correo en ambos lados usando pernos y tuercas. (Vea Diagrama 2)
2. Coloque las canastas en el ensamble del carrito.
3. Coloque las varillas guía en la canasta superior. (Vea Diagrama 3)

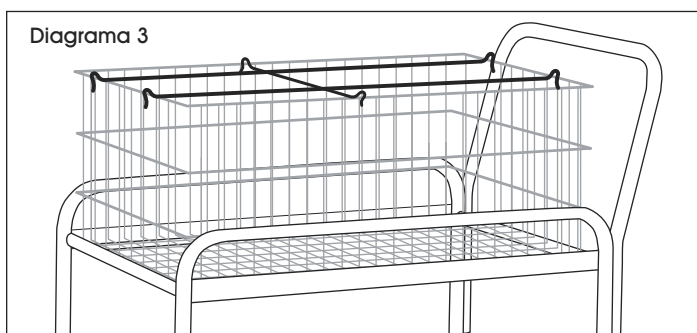
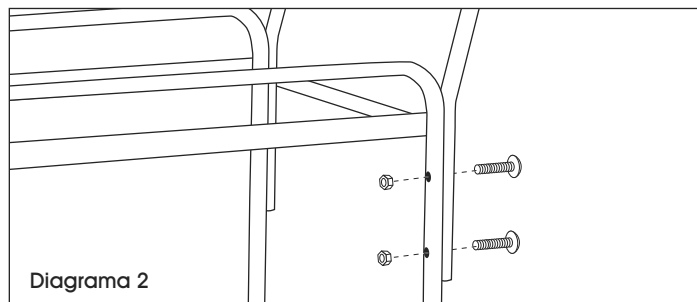
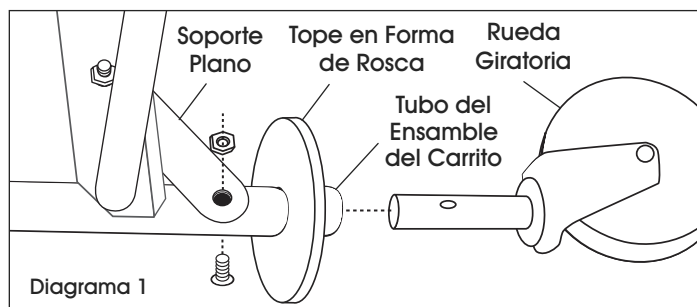

ULINE

800-295-5510

uline.mx

ULINE H-1199

CHARIOT POUR LE COURRIER

1 800 295-5510
uline.ca



OUTILS REQUIS

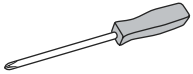

Tournevis cruciforme



Clé à molette



Maillet en caoutchouc

PIÈCES



REMARQUE : Le matériel de fixation est déjà préinstallé sur le chariot. Des pièces de fixation supplémentaires sont également fournies.

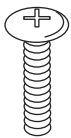

Boulon de 2 po x 4

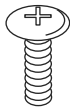

Boulon de 1 1/4 po x 4



Boulon de 3/8 po x 4



Écrou de 3/16 po x 4



Écrou de 1/4 po x 8

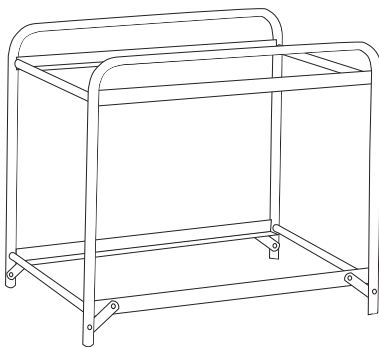

Structure du chariot x 1



Poignée x 1



Tige de guidage x 3

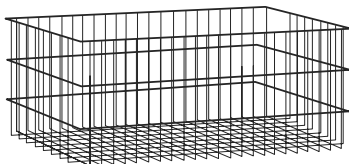

Panier supérieur x 1

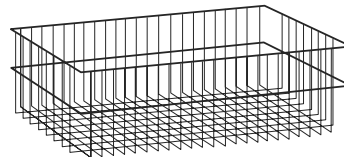

Panier inférieur x 1



Pare-chocs de roulette x 2

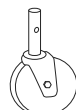

Roulette pivotante de 4 po x 2



Roulette fixe de 4 po x 2

AVANT DE COMMENCER

1. Retirez tous les composants de la boîte.
2. Placez la structure du chariot à l'envers (les extrémités ouvertes orientées vers le haut).

INSTALLATION DES ROULETTES AVANT

Répez le devant de la structure du chariot.

 **REMARQUE :** Vous pouvez identifier le devant de la structure par l'absence de trous de montage destinés à l'installation de la poignée. (Voir Figure 2)

1. Retirez le boulon de la barre de renfort plate située sur le tube de la structure du chariot. Desserrez l'autre boulon si nécessaire. (Voir Figure 1)
2. Glissez le pare-chocs de roulette sur le tube de la structure du chariot.
3. Insérez la roulette pivotante de 4 po dans le tube de la structure du chariot.

 **REMARQUE :** Tapotez sur les roulettes pour les fixer en place avec un maillet en caoutchouc si nécessaire.

4. Insérez le boulon dans les trous de la barre de renfort plate, de la roulette et du tube de la structure du chariot. Fixez à l'aide d'un écrou. Serrez fermement.
5. Répétez ces étapes pour installer l'autre roulette pivotante de l'autre côté.

INSTALLATION DES ROULETTES ARRIÈRE

1. Retirez le boulon de la barre de renfort plate située sur le tube de la structure du chariot. Desserrez l'autre boulon si nécessaire.
2. Insérez la roulette fixe de 4 po dans le tube de la structure du chariot.

 **REMARQUE :** Tapotez sur les roulettes pour les fixer en place avec un maillet en caoutchouc si nécessaire.

3. Insérez le boulon dans les trous de la barre de renfort plate, de la roulette et du tube de la structure du chariot. Fixez à l'aide d'un écrou. Serrez fermement.
4. Répétez ces étapes pour installer l'autre roulette fixe de l'autre côté.

INSTALLATION DES AUTRES PIÈCES

1. Placez le chariot à la verticale et fixez les deux côtés de la poignée à l'arrière du chariot à l'aide de boulons et d'écrous. (Voir Figure 2)
2. Placez les paniers sur la structure du chariot.
3. Installez les tiges de guidage sur le panier

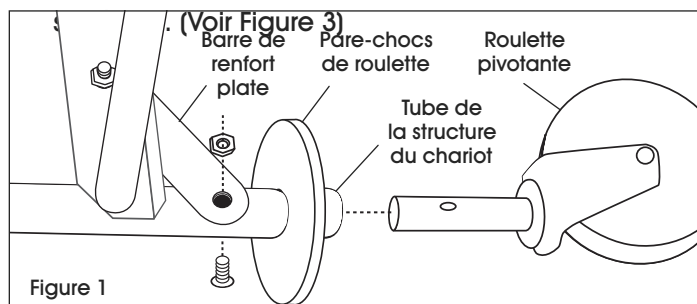

Figure 1

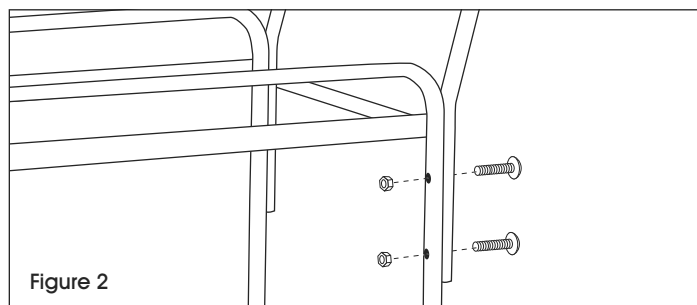

Figure 2

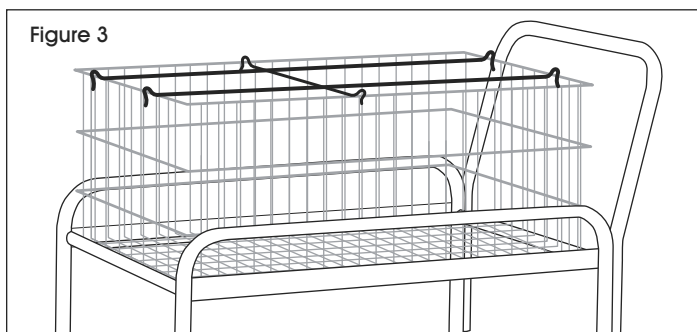

Figure 3

ULINE

1 800 295-5510

uline.ca