

ULINE H-1205WH-BL, H-4305
H-1205WH-C, H-7569
**POLYURETHANE CASTERS
FOR WIRE SHELVING UNITS**

1-800-295-5510
uline.com

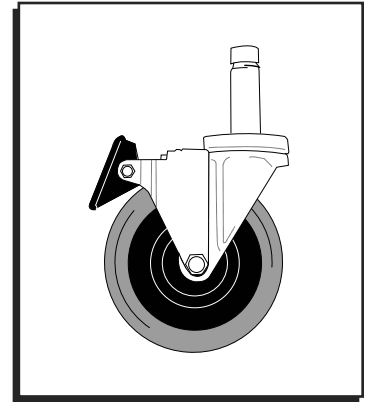

TOOL NEEDED



Rubber Mallet
(optional)

CASTER INSTALLATION

1. Ensure post is positioned as shown.
(See Figure 1)
2. Engage the wheel brakes to keep casters from rolling during assembly. Use a rubber mallet to tap caster stems into posts. (See Figure 1)

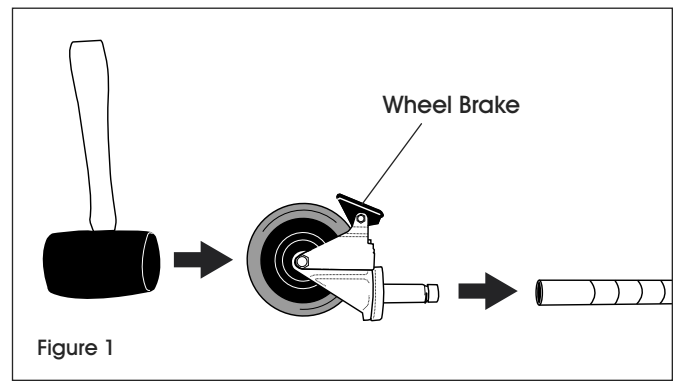

Figure 1

ULINEH-1205WH-BL, H-4305
H-1205WH-C, H-7569800-295-5510
uline.mx

RUEDAS DE POLIURETANO PARA UNIDADES DE ESTANTERÍA DE ALAMBRE

HERRAMIENTA NECESARIA



Mazo de Caucho
(opcional)

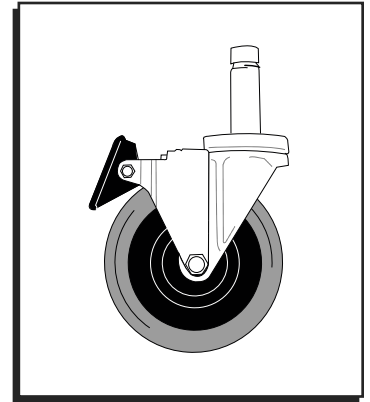

INSTALACIÓN DE RUEDAS

1. Asegúrese de que el poste esté posicionado como se muestra. (Vea Diagrama 1)
2. Ponga el seguro en las llantas para evitar que se rueden durante el ensamble. Utilice un mazo de caucho para insertar el vástago de las ruedas dentro de los postes. (Vea Diagrama 1)

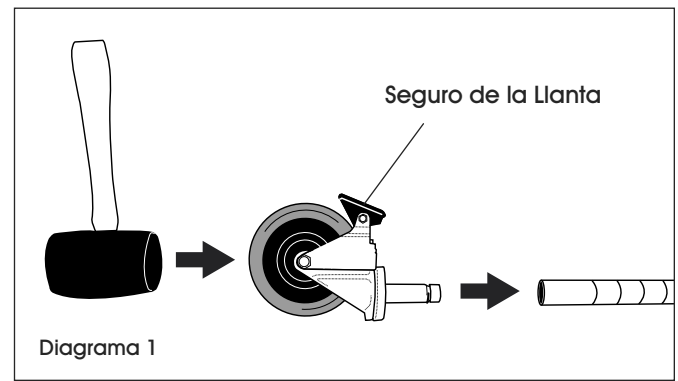

ULINEH-1205WH-~~B1~~, ~~HH-43005~~
H-1205WH-~~B1~~, ~~HH-75669~~1 800 295-5510
uline.ca

ROULETTES EN POLYURÉTHANE POUR UNITÉS DE RAYONNAGE EN FIL DE MÉTAL

OUTIL REQUIS

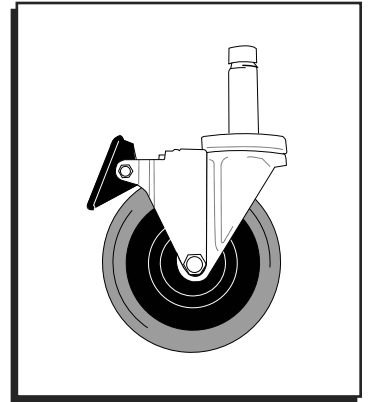
Maillet en caoutchouc
(optionnel)

INSTALLATION DES ROULETTES

1. Assurez-vous que le montant est placé comme illustré. (Voir Figure 1)
2. Enclenchez le frein pour empêcher les roulettes de rouler pendant le montage. Utilisez un maillet en caoutchouc pour insérer la tige des roulettes dans les montants. (Voir Figure 1)

