

# ULINE H-1219 PRESSED WOOD PALLET

1-800-295-5510  
 uline.com

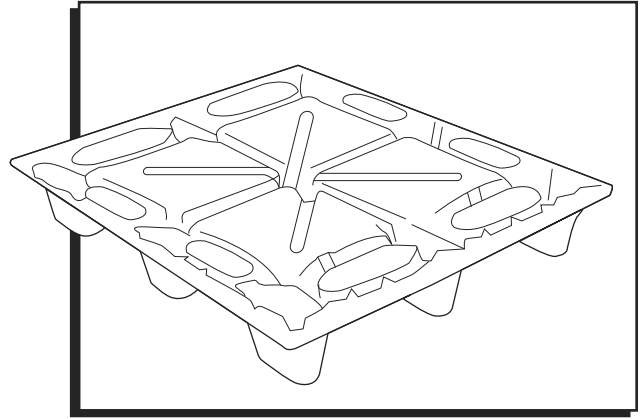

## DIMENSIONS

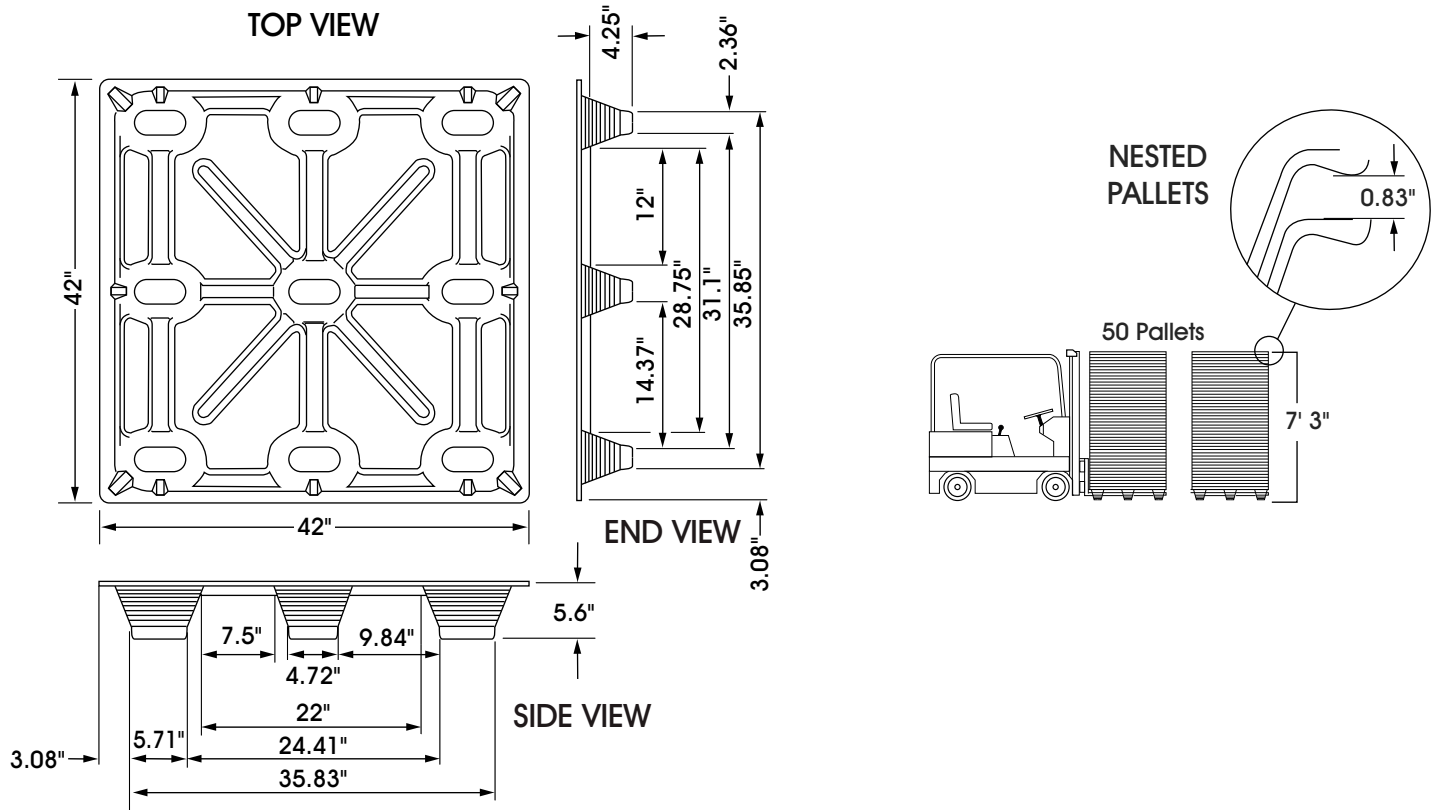

## SPECIFICATIONS

MODEL #	DIMENSIONS		HEIGHT			NESTED TRAILER		WEIGHT CAPACITY		WEIGHT
	L	W	FORK	OVERALL	NESTING	48'	53'	FLOOR	FORK	
H-1219	42"	42"	4.25"	5.6"	1.35"	1,180	1,280	15,000 lbs.	1,500 lbs.	34 lbs.

**ULINE** H-1219

**TARIMA DE MADERA  
PRENSADA**

800-295-5510  
uline.mx

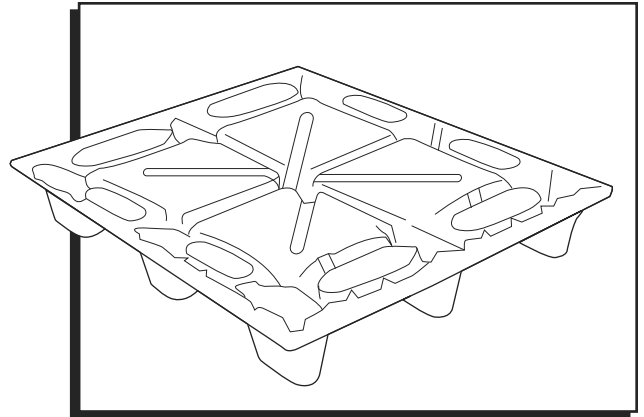

**DIMENSIONES**

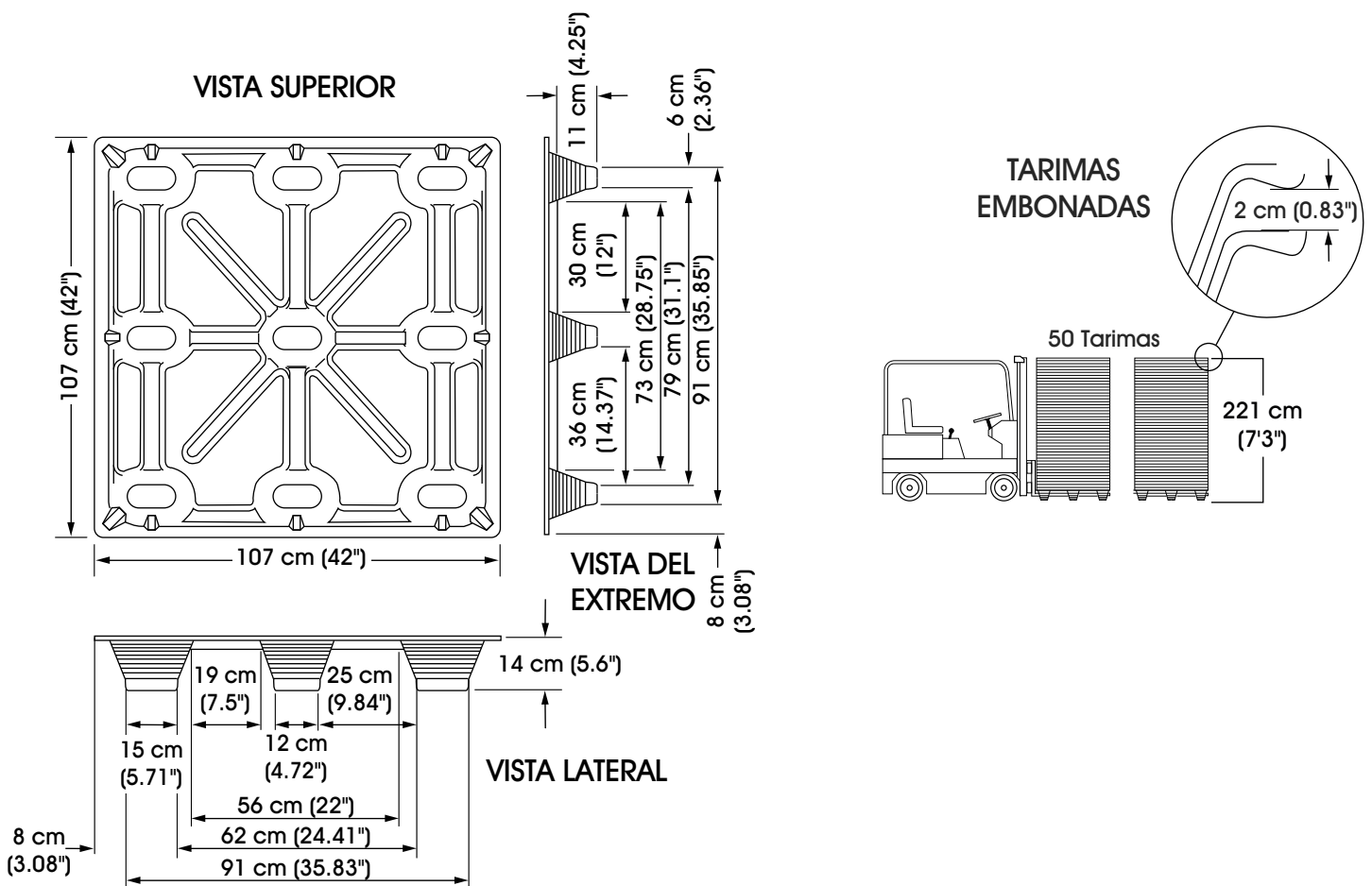

**ESPECIFICACIONES**

MODELO NO.	DIMENSIONES		ALTURA			EMBONADAS EN TRÁILER		CAPACIDAD DE PESO		PESO
	LARGO	ANCHO	HORQUILLA	TOTAL	EMBONABLE	14.6 m (48')	16.15 m (53')	PISO	HORQUILLA	
H-1219	107 cm (42")	107 cm (42")	11 cm (4.25")	14 cm (5.6")	3 cm (1.35")	1,180	1,280	6,803 kg (15,000 lbs.)	680 kg (1,500 lbs.)	15 kg (34 lbs.)

**ULINE H-1219**  
**PALETTE EN BOIS**  
**PRESSÉ**

1-800-295-5510  
 uline.ca

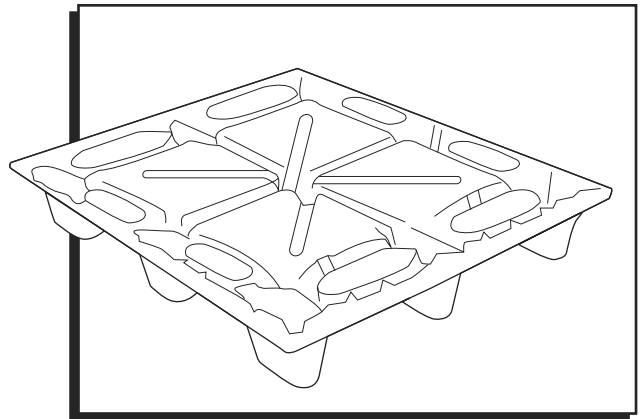

**DIMENSIONS**

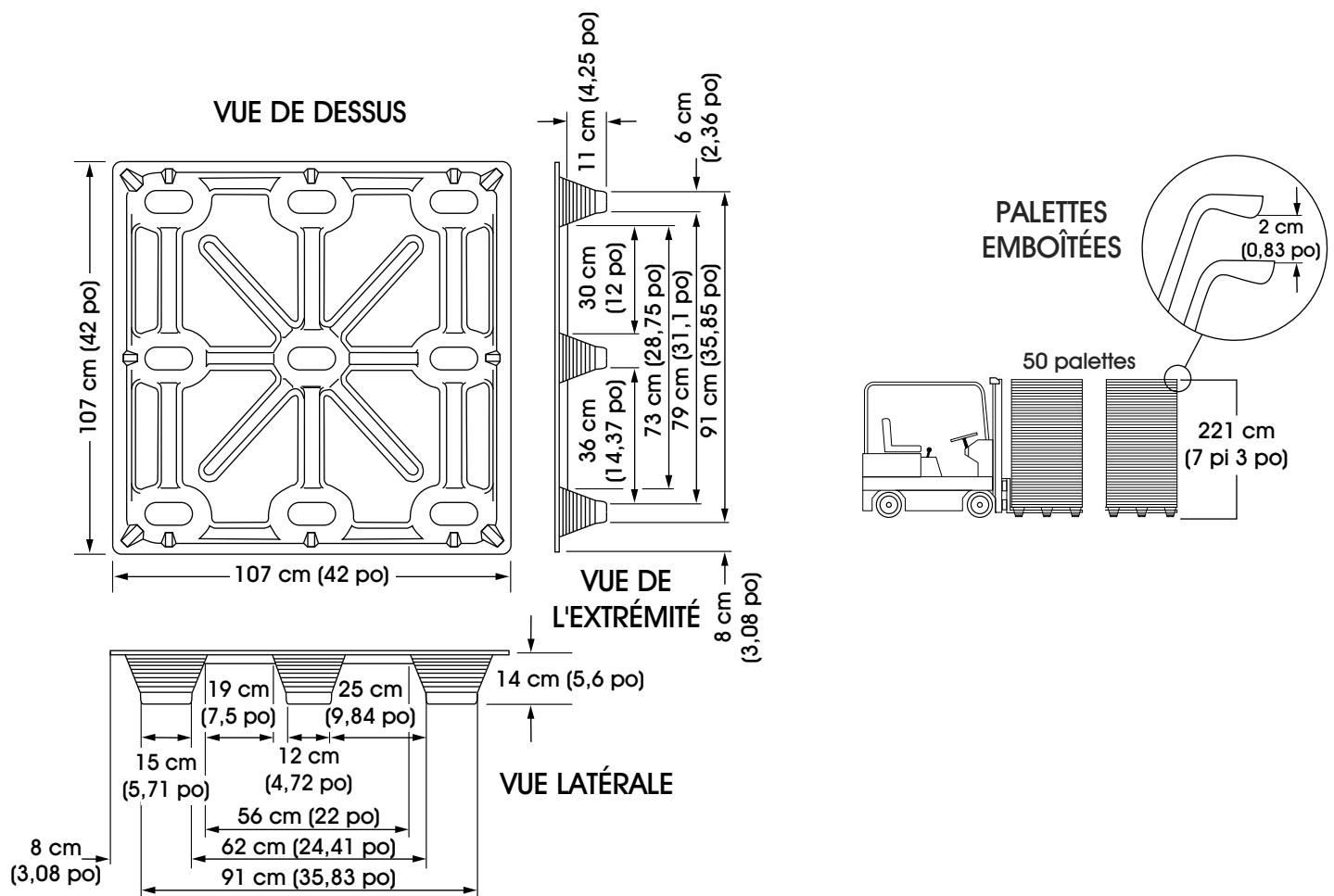

**SPÉCIFICATIONS**

N° DE MODÈLE	DIMENSIONS		HAUTEUR			REMORQUE EMBOÎTÉE		CAPACITÉ PONDÉRALE		POIDS
	LONG.	LARG.	FOURCHE	TOTALE	EMBOÎTEMENT	14,6 m (48 pi)	16,15 m (53 pi)	PLANCHER	FOURCHE	
H-1219	107 cm (42 po)	107 cm (42 po)	11 cm (4,25 po)	14 cm (5,6 po)	3 cm (1,35 po)	1 180	1 280	6 803 kg (15 000 lb)	680 kg (1 500 lb)	15 kg (34 lb)