

# ULINE H-1222, H-2484

## 96" PACKING TABLES

1-800-295-5510  
 uline.com

### TOOLS NEEDED

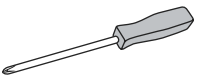

Phillips Head  
Screwdriver



7/16" Wrench

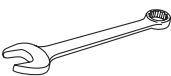

3/8" Wrench  
10 mm Wrench  
(For Non-Steel Top Assembly)

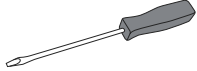

Flat Head  
Screwdriver

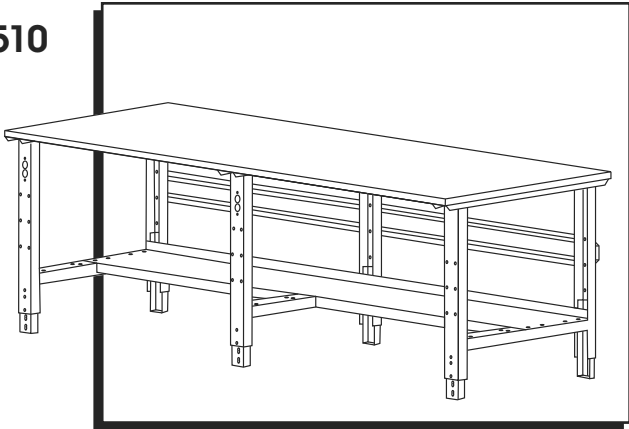

### PARTS

Hardware Kit

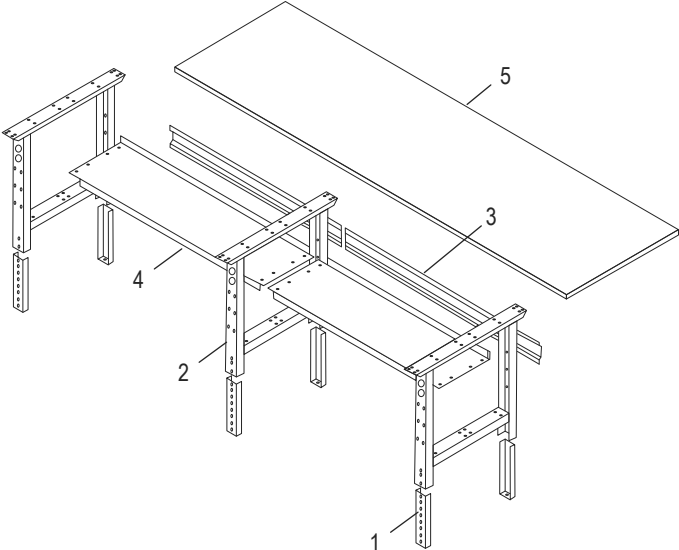
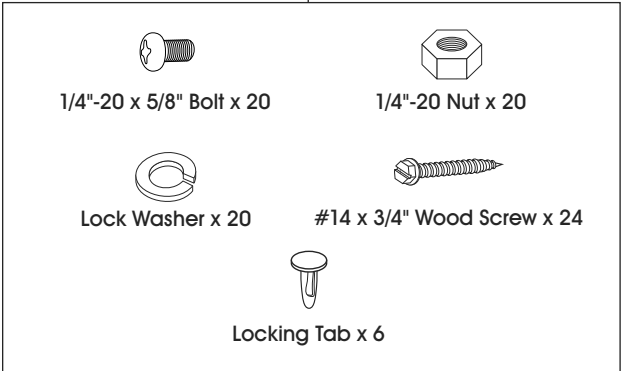

#	DESCRIPTION	QTY
1	Adjustable Foot	6
2	Leg	3
3	Stringer	2
4	Lower Shelf	2
5	Tabletop	1



**STOP** If you purchased L-Shaped Workstation or Deluxe Workstation, use instructions packaged with H-5777 uprights.

### ASSEMBLY

#### LEGS AND FRAME ASSEMBLY

1. Insert adjustable feet (1) into legs (2) and slide into place at desired height.

**NOTE:** If desired, insert locking tabs through legs and adjustable feet to lock feet into place.

2. Place legs (2) in upright position. Legs should be placed approximately 45" apart.

3. Attach stringers (3) to table legs using center six holes in back legs. Fasten with 12 bolts, lock washers and nuts, but do not fully tighten. (See Figure 1)

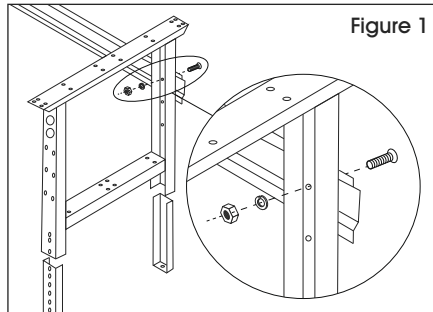

## ASSEMBLY CONTINUED

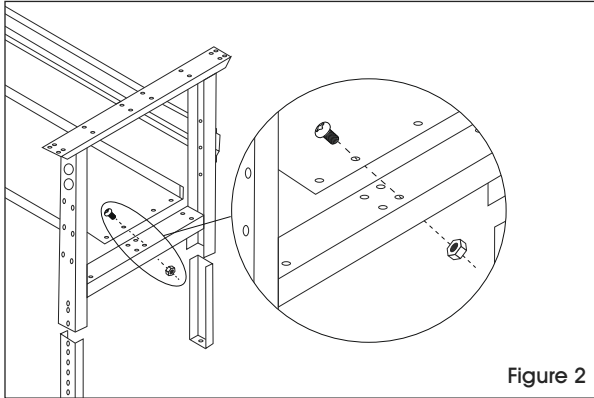

Figure 2

- Place lower shelves (4) across braces of legs. Attach lower shelves using eight nuts and bolts. Now, fully fasten hardware placed in step 3. (See Figure 2)
- To attach tabletop (5) to frame assembly, place tabletop on a smooth, non-marring surface with top side facing down.
- Rotate the assembled frame upside down and line up with the pre-drilled holes on the bottom side of the top.

### NON-STEEL TOP ASSEMBLY

(Composite Wood, Laminate, Maple, Stainless Steel, ESD)

- Using 24 wood screws, attach legs to the under side of the top (5) through pre-drilled holes. (See Figure 3)



**NOTE:** Not all pre-drilled holes in tabletop will be used for assembly.

- Set bench assembly upright and recheck all nuts, bolts and screws for tightness.

### STEEL TOP ASSEMBLY

Hardware pack includes:

DESCRIPTION	QTY
1/4"-20 x 5/8" Bolts	41
1/4"-20 Nuts	29
Lock Washers	29



**NOTE:** There are two mounting channels provided for installing an optional cabinet or drawer.

- Align leg holes to end of tabletop. Secure with six 1/4"-20 x 5/8" bolts. Threaded inserts are provided on each tabletop end. (See Figure 4)
- Attach center leg using four 1/4"-20 x 5/8" bolts, four lock washers and four 1/4"-20 nuts.



**NOTE:** Center of table does not include threaded inserts.

- Set bench assembly upright and recheck all bolts for tightness.

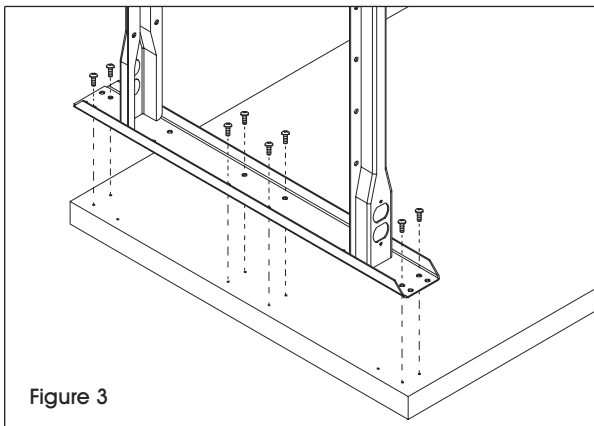

Figure 3

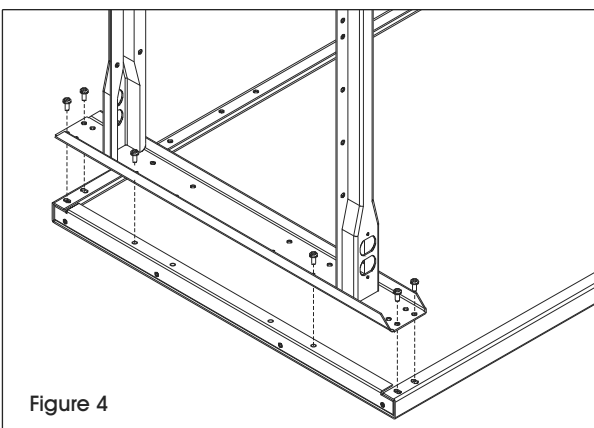

Figure 4

**ULINE**

1-800-295-5510

uline.com

# ULINE H-1222, H-2484

## MESAS DE TRABAJO DE 96"

800-295-5510  
uline.mx

### HERRAMIENTAS NECESARIAS

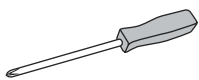

Desarmador de Cruz

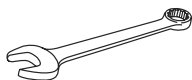

Llave de 7/16"

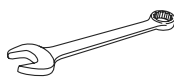

Llave de 3/8"  
Llave de 10 mm  
(Para Ensamblar Cubiertas que no Sean de Acero)

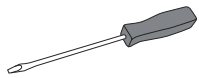

Desarmador Plano

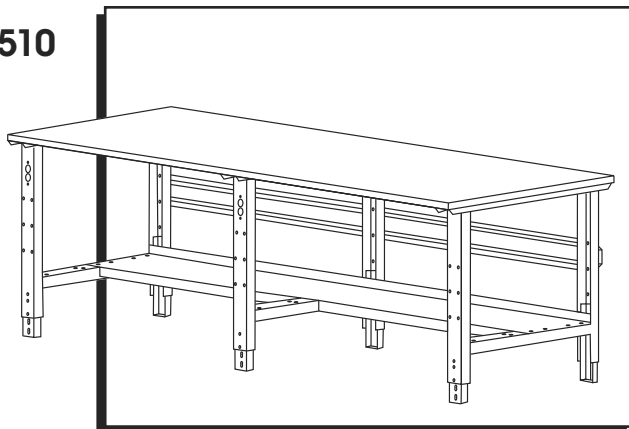

### PARTES

#### Kit de Accesorios

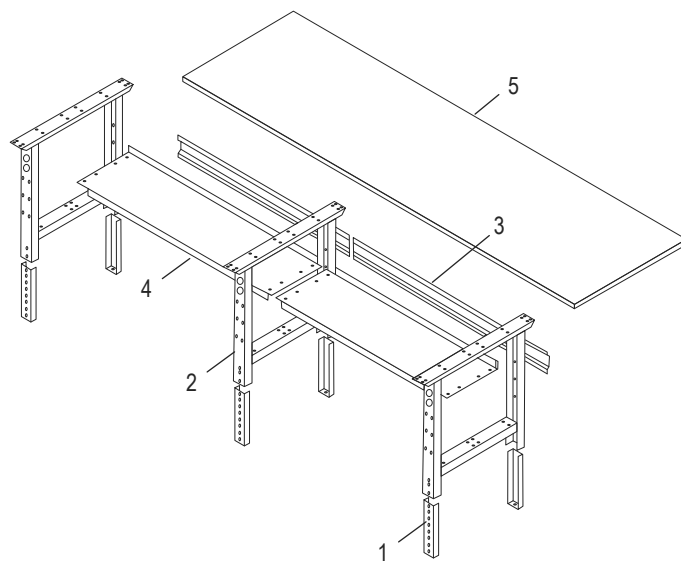
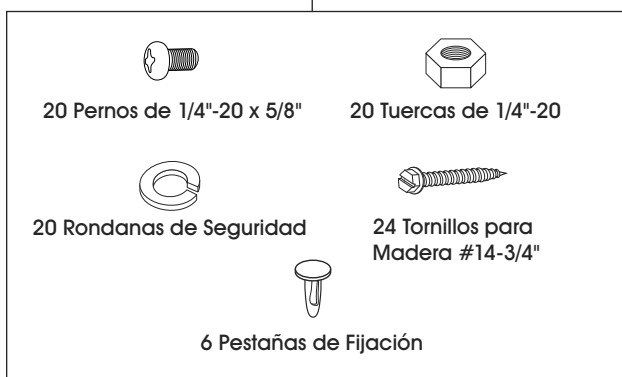

#	DESCRIPCIÓN	CANT.
1	Pata Ajustable	6
2	Poste	3
3	Larguero	2
4	Repisa Inferior	2
5	Cubierta	1



Si adquirió la Estación de Trabajo en L o la de Alta Calidad, use las instrucciones empacadas con los postes H-5777.

### ENSAMBLE

#### ENSAMBLE DE LOS POSTES Y EL ARMAZÓN

1. Inserte las patas ajustables (1) dentro de los postes (2) y deslícelos en su lugar a la altura deseada.



**NOTA:** Si lo desea, inserte las pestañas de fijación a través de los postes y las patas ajustables para asegurarlas en su lugar.

2. Coloque los postes (2) en posición vertical. Los postes deben colocarse con una separación de aproximadamente 1.14 m (45").

3. Fije los largueros (3) a los postes de la mesa utilizando los seis orificios centrales de los postes posteriores. Fije con 12 pernos, rondanas de seguridad y tuercas, pero no los apriete por completo. (Vea Diagrama 1)

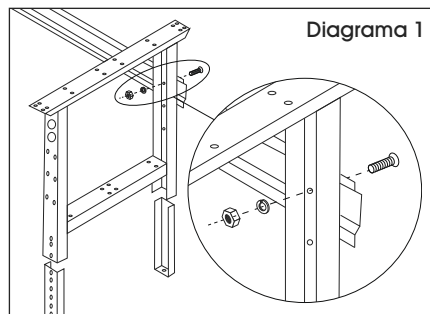

## CONTINUACIÓN DEL ENSAMBLE

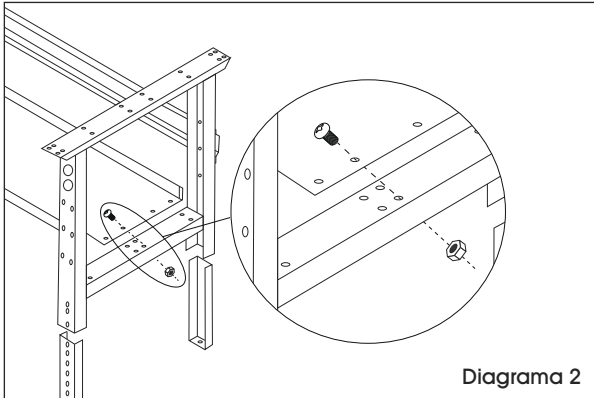

- Coloque las repisas inferiores (4) cruzando los travesaños de los postes. Fije las repisas inferiores utilizando ocho tuercas y pernos. Luego, apriete por completo la tornillería colocada en el paso 3. (Vea Diagrama 2)
- Para fijar la cubierta (5) al ensamblaje del armazón, voltee la cubierta hacia abajo sobre una superficie lisa, que no deje marcas.
- Voltee el armazón ensamblado y alinéelo con los orificios preperforados de la parte inferior de la cubierta.

### ENSAMBLE DE UNA CUBIERTA QUE NO SEA DE ACERO

(Madera Comprimida, Laminado, Arce, Acero Inoxidable, ESD)

- Utilizando 24 tornillos para madera, fije los postes a la parte inferior de la cubierta (5) a través de los orificios preperforados. (Vea Diagrama 3)

**NOTA:** No todos los orificios en la cubierta se usarán para el ensamblaje.

- Enderece el ensamblaje y revise de nuevo que todas las tuercas, pernos y tornillos estén apretados.

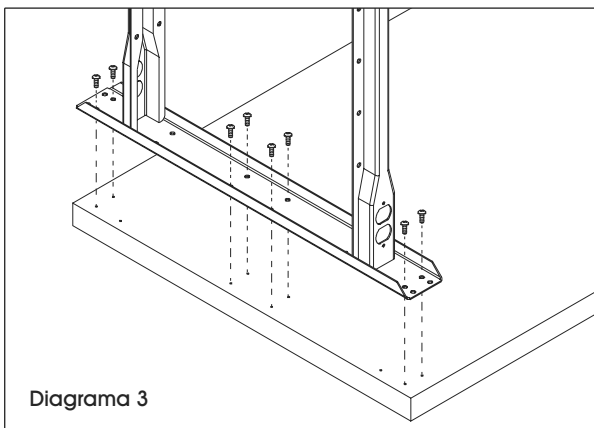

### ENSAMBLE DE UNA CUBIERTA DE ACERO

El paquete de tornillería incluye:

DESCRIPCIÓN	CANT.
Pernos de 1/4"-20 x 5/8"	41
Tuercas de 1/4"-20	29
Rondanas de Seguridad	29

**NOTA:** Existen dos canales de instalación para poder agregar un gabinete o cajón opcional.

- Alinee los orificios de los postes al extremo de la cubierta de la mesa. Asegure con seis pernos de 1/4"-20 x 5/8". Se proporcionan insertos roscados en cada extremo de la cubierta de la mesa. (Vea Diagrama 4)

- Fije el poste central usando cuatro pernos de 1/4"-20 x 5/8", cuatro rondanas de seguridad y cuatro tuercas de 1/4"-20.

**NOTA:** El centro de la mesa no incluye insertos roscados.

- Enderece el ensamblaje y revise de nuevo que todos los pernos estén apretados.

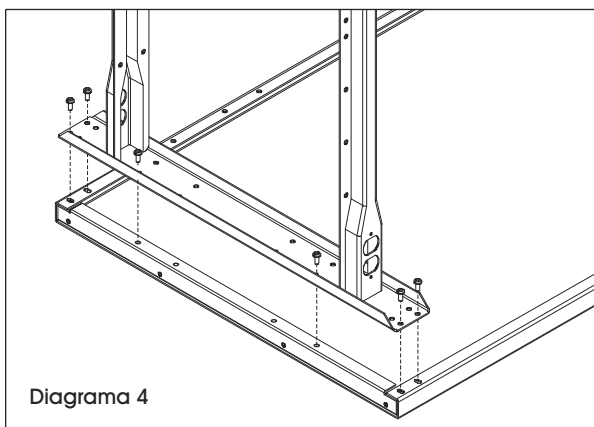

**ULINE**

800-295-5510  
uline.mx

# ULINE H-1222, H-2484

## TABLES D'EMBALLAGE DE 96 PO

1 800 295-5510  
uline.ca

### OUTILS REQUIS

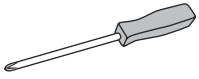

Tournevis  
cruziforme

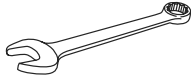

Clé de 7/16 po

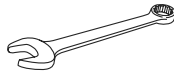

Clé de 3/8 po  
Clé de 10 mm  
(pour le montage de dessus  
de table autre qu'en acier)

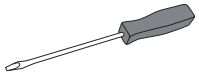

Tournevis  
à tête plate

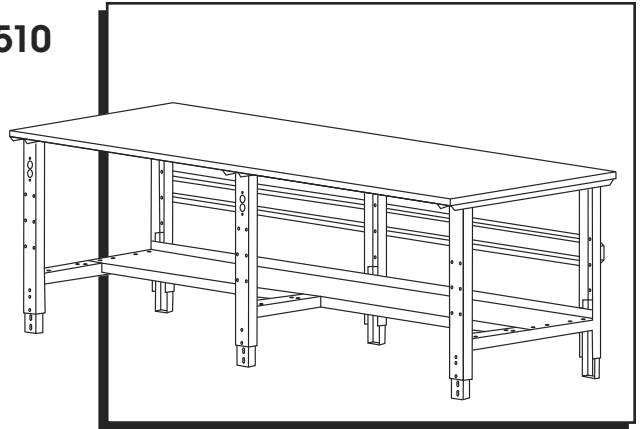

## PIÈCES

Ensemble de matériel

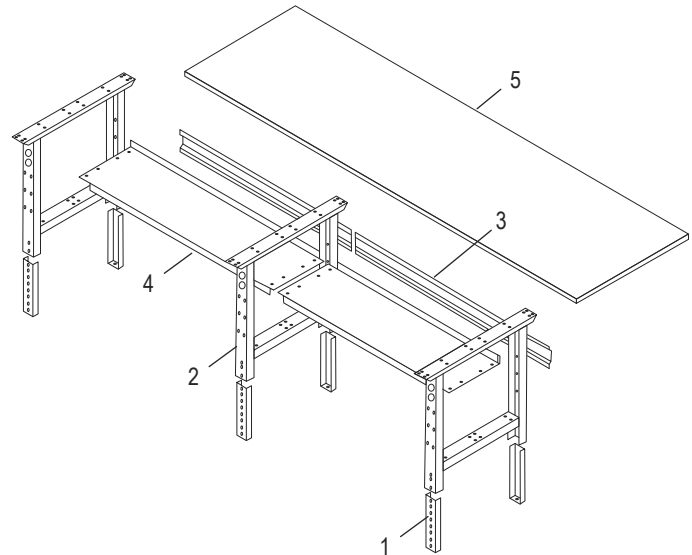
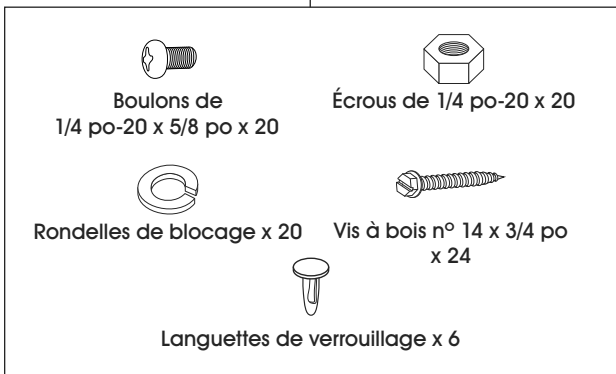

#	DESCRIPTION	QTÉ
1	Patte réglable	6
2	Pied	3
3	Longeron	2
4	Tablette inférieure	2
5	Dessus de table	1



Si vous avez acheté un poste de travail en L ou un poste de travail de luxe, utilisez les instructions incluses avec les montants du H-5777.

## MONTAGE

### MONTAGE DES PIEDS ET DU CADRE

1. Insérez les pattes réglables (1) dans les pieds (2) et glissez-les jusqu'à la hauteur désirée.



**REMARQUE :** Si vous le souhaitez, insérez les languettes de verrouillage à travers les pieds et les pattes réglables pour verrouiller les pattes en position.

2. Placez les pieds (2) en position verticale. Les pieds doivent être placés à environ 1,1 m (45 po) l'un de l'autre.

3. Fixez le longeron (3) aux pieds de la table en vous servant des six trous centraux des pieds arrière. Fixez-le à l'aide de 12 boulons, rondelles et écrous, mais ne serrez pas complètement. (Voir Figure 1)

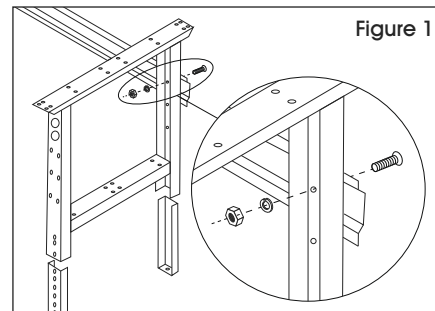

## MONTAGE SUITE

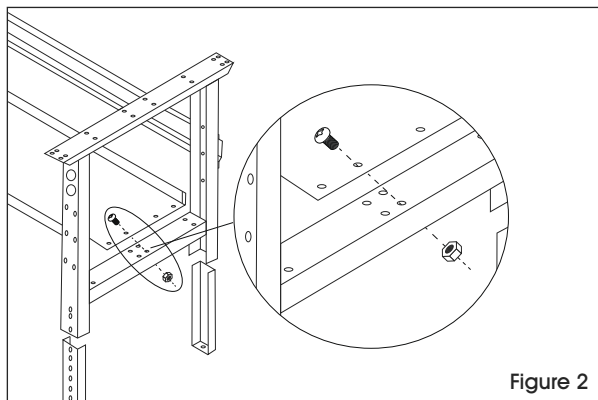

Figure 2

- Placez les tablettes inférieures (4) sur les entretoises des pieds, et fixez-les à l'aide de huit écrous et boulons. Ensuite, serrez complètement les pièces installées à l'étape 3. (Voir Figure 2)
- Pour fixer le dessus de table (5) à l'ensemble du cadre, placez-le sur une surface lisse et non marquante, côté supérieur vers le bas.
- Retournez le cadre assemblé et alignez-le sur les trous prépercés du côté inférieur du dessus de table.

### MONTAGE D'UN DESSUS AUTRE QU'EN ACIER

(bois composite, stratifié, érable, acier inoxydable, DES)

- À l'aide de 24 vis à bois, fixez les pieds au côté inférieur du dessus de table (5), par les trous prépercés. (Voir Figure 3)

 **REMARQUE :** Les trous prépercés dans le dessus de table ne seront pas tous utilisés pour le montage.

- Placez l'ensemble de la table à l'endroit et vérifiez que tous les écrous, vis et boulons sont bien serrés.

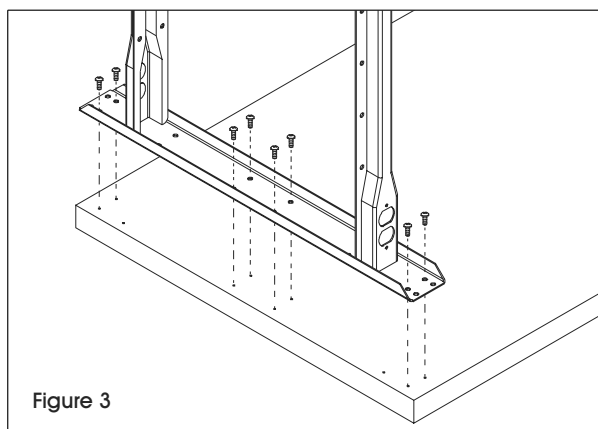



Figure 3

### MONTAGE D'UN DESSUS EN ACIER

L'ensemble de matériel comprend :

DESCRIPTION	QTÉ
Boulons de 1/4 po-20 x 5/8 po	41
Écrous de 1/4 po-20	29
Rondelles de blocage	29

 **REMARQUE :** Deux profilés de fixation sont fournis pour une installation optionnelle d'une armoire ou d'un tiroir.

- Alignez les trous des pieds avec l'extrémité du dessus de table. Fixez à l'aide de six boulons de 1/4 po-20 x 5/8 po. Des sections filetées sont fournies à chaque extrémité du dessus de table. (Voir Figure 4).
- Fixez le pied central à l'aide de quatre boulons de 1/4 po-20 x 5/8 po, de quatre rondelles de blocage et de quatre écrous de 1/4 po-20.

 **REMARQUE :** La partie centrale de la table ne dispose pas de sections filetées.

- Placez la table à l'endroit, puis vérifiez que tous les boulons sont serrés.

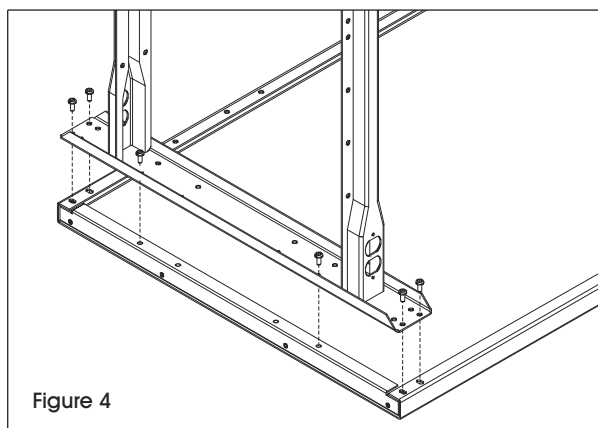

Figure 4

**ULINE**

1 800 295-5510  
uline.ca