

ULINE H-1260
HEAT TREATED
WOOD PALLET

1-800-295-5510
 uline.com

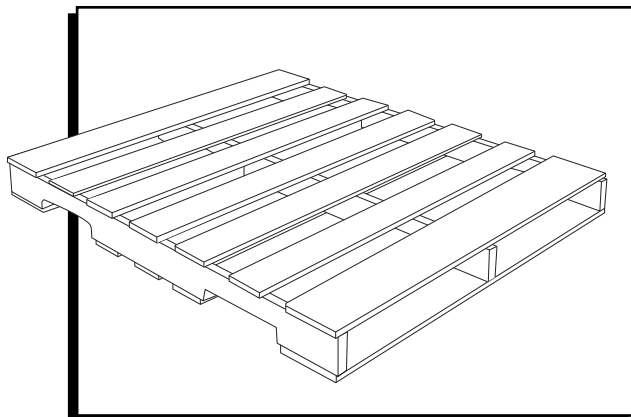

PRODUCT DIMENSIONS

TOP VIEW

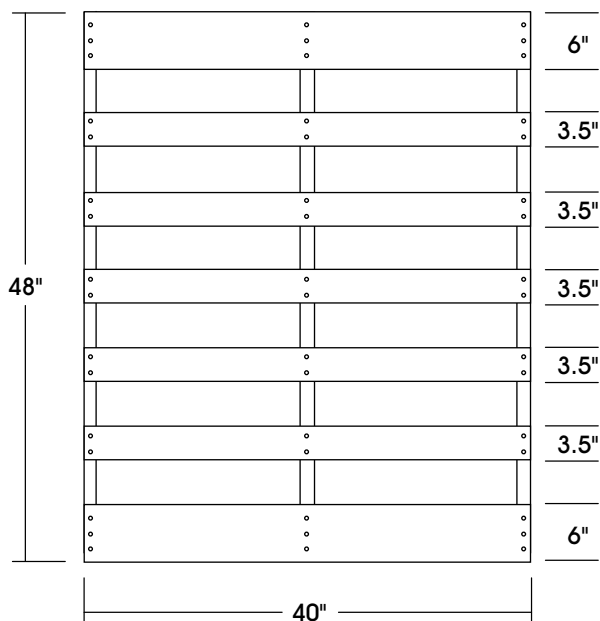

SIDE VIEW

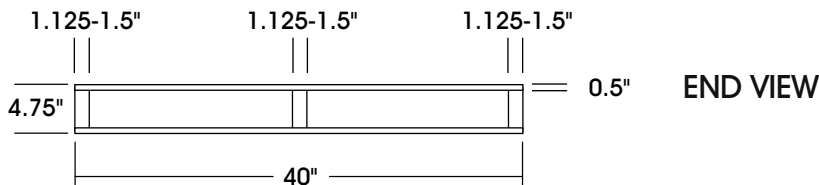
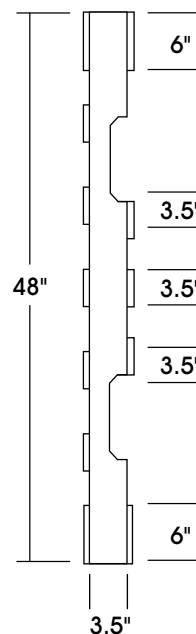

SPECIFICATIONS

MODEL #	DIMENSIONS		HEIGHT		TRAILER QUANTITY		WEIGHT CAPACITY		WEIGHT
	L	W	FORK	OVERALL	48'	53'	FLOOR	FORK	
H-1260	48"	40"	3.5"	4.75"	560	600	7,525 lbs.	2,500 lbs.	40 lbs.

ULINE H-1260

800-295-5510

uline.mx

**TARIMA DE
MADERA TRATADA
CON CALOR**

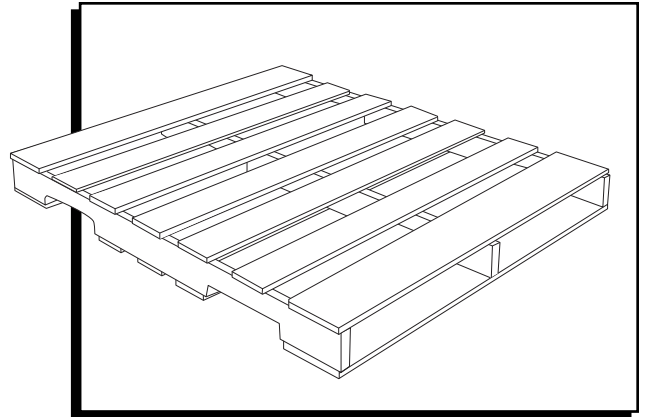

DIMENSIONES DEL PRODUCTO

VISTA SUPERIOR

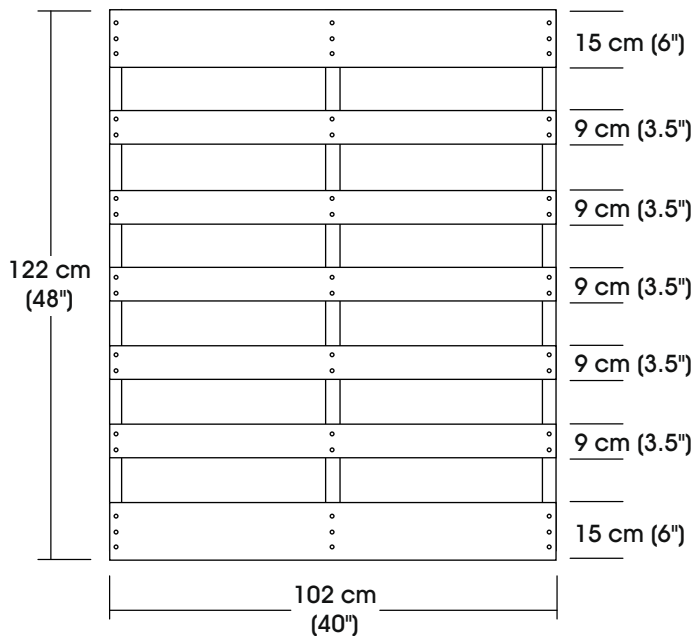

VISTA DEL EXTREMO

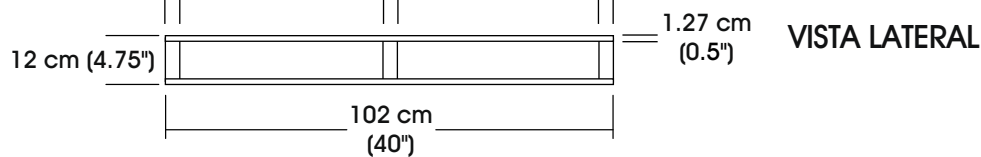
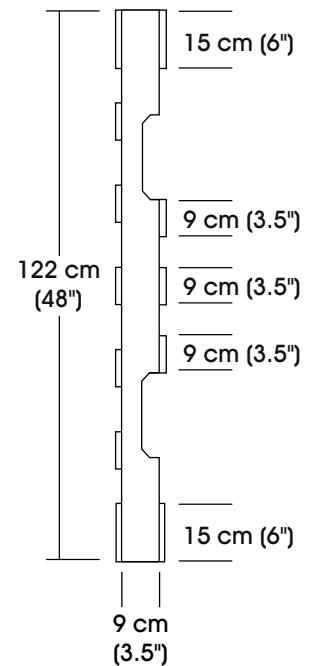

ESPECIFICACIONES

MODELO NO.	DIMENSIONES		ALTO		CANTIDAD POR TRÁILER		CAPACIDAD DE PESO		PESO
	LARGO	ANCHO	HORQUILLA	TOTAL	14.6 m (48')	16.15 m (53')	PISO	HORQUILLA	
H-1260	122 cm (48")	102 cm (40")	9 cm (3.5")	12 cm (4.75")	560	600	3,413 kg (7,525 lbs.)	1,133 kg (2,500 lbs.)	18 kg (40 lbs.)

ULINE H-1260
PALETTE DE BOIS
TRAITÉ À LA
CHALEUR

1 800 295-5510
 uline.ca

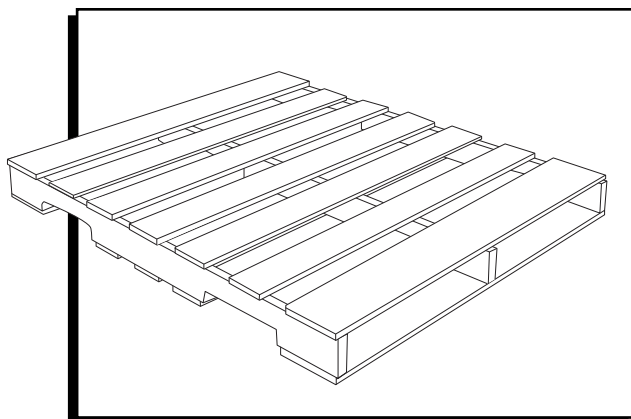

DIMENSIONS DU PRODUIT

VUE DE DESSUS

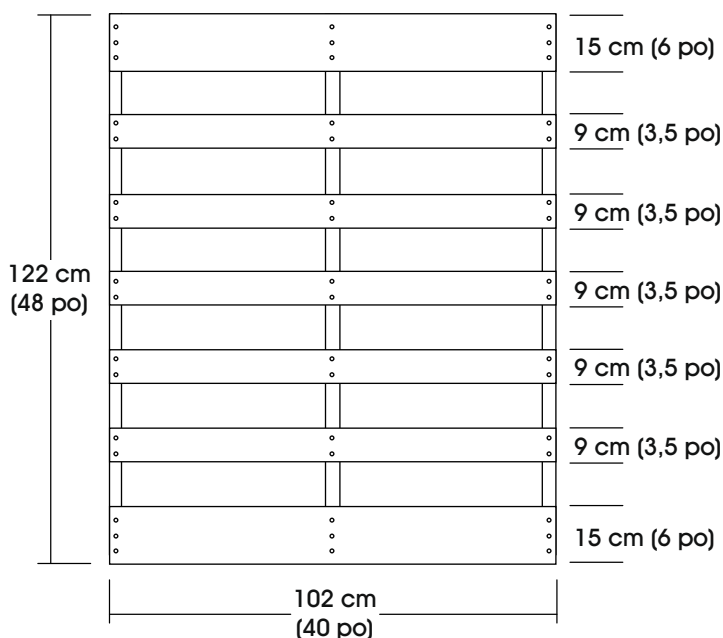

VUE DE L'EXTRÉMITÉ

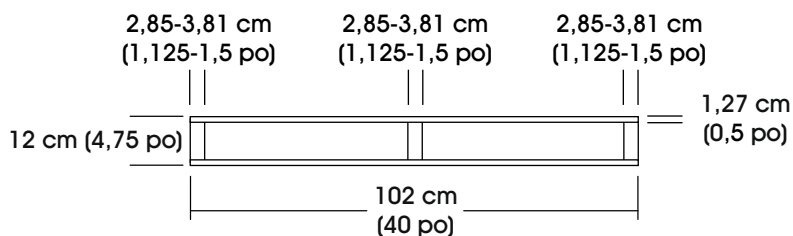
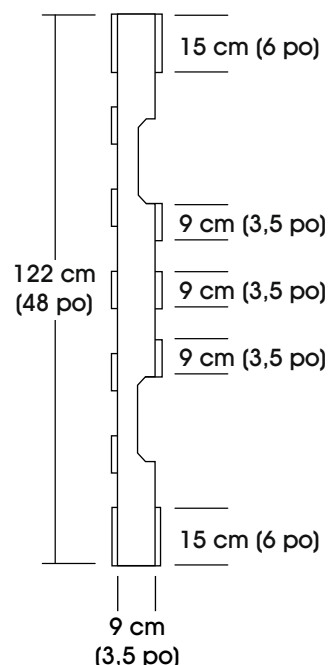

VUE LATÉRALE

SPÉCIFICATIONS

N° DE MODÈLE	DIMENSIONS		HAUTEUR		QUANTITÉ PAR REMORQUE		CAPACITÉ PONDÉRALE		POIDS
	LONG.	LARG.	FOURCHE	TOTALE	14,6 m (48 pi)	16,15 m (53 pi)	PLANCHER	FOURCHE	
H-1260	122 cm (48 po)	102 cm (40 po)	9 cm (3,5 po)	12 cm (4,75 po)	560	600	3 413 kg (7 525 lb)	1 133 kg (2 500 lb)	18 kg (40 lb)