

ULINE H-12625 MOBILE PRIVACY DIVIDER

1-800-295-5510
uline.com

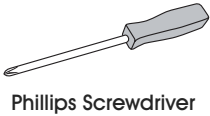

TOOLS NEEDED



Phillips Screwdriver



Allen Wrench
(included)

PARTS

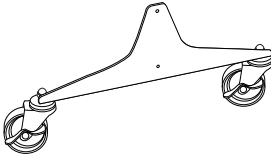

Foot with Casters x 2

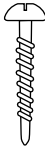

Screw x 2



Button Bolt x 4



Spacer x 4

ASSEMBLY

NOTE: Hardware ships attached to panel.

1. Lay panel on its side. Remove two button bolts and spacers from bottom edge of each outer panel with the Allen wrench and one screw from the side of each outer panel with a Phillips screwdriver. (See Figure 1)

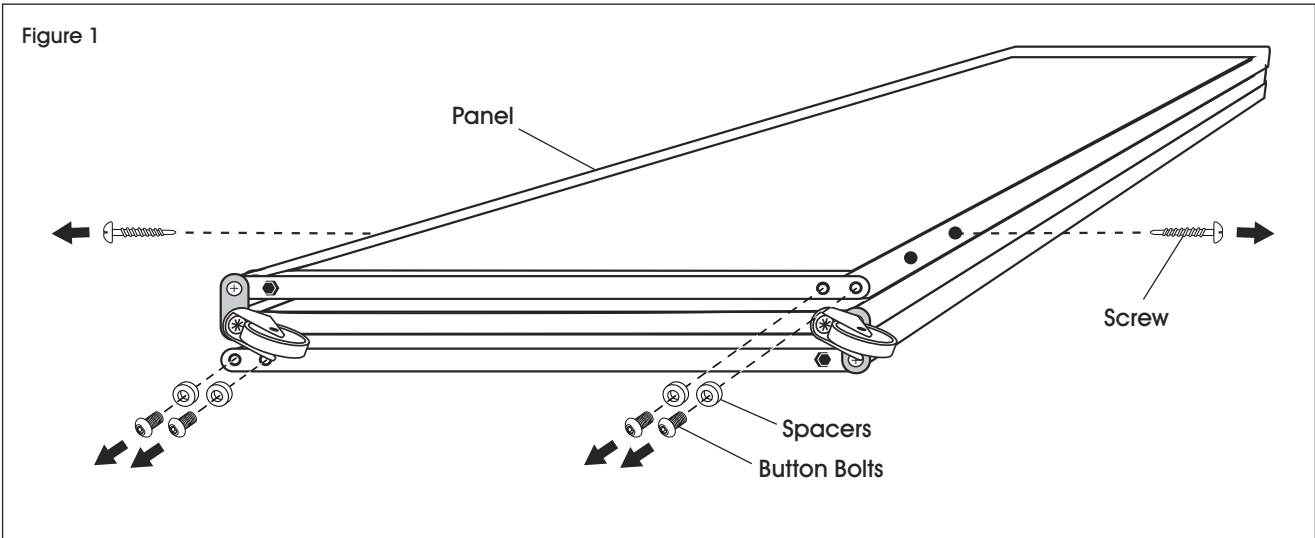

ASSEMBLY CONTINUED

2. Attach the foot base to bottom edge of panel with two previously removed spacers and button bolts. Repeat on opposite side. (See Figure 2)

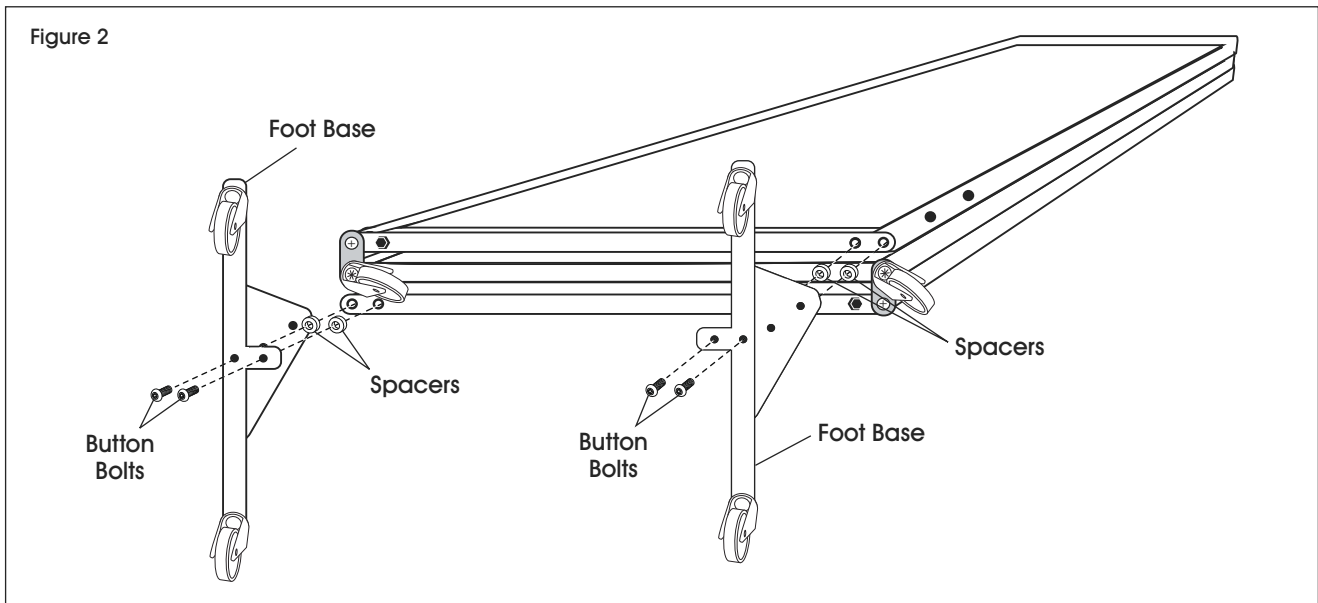

3. Attach top of foot base to the side of outer panel with previously removed screw. Repeat on opposite side. (See Figure 3) Lift panel upright for completed assembly.

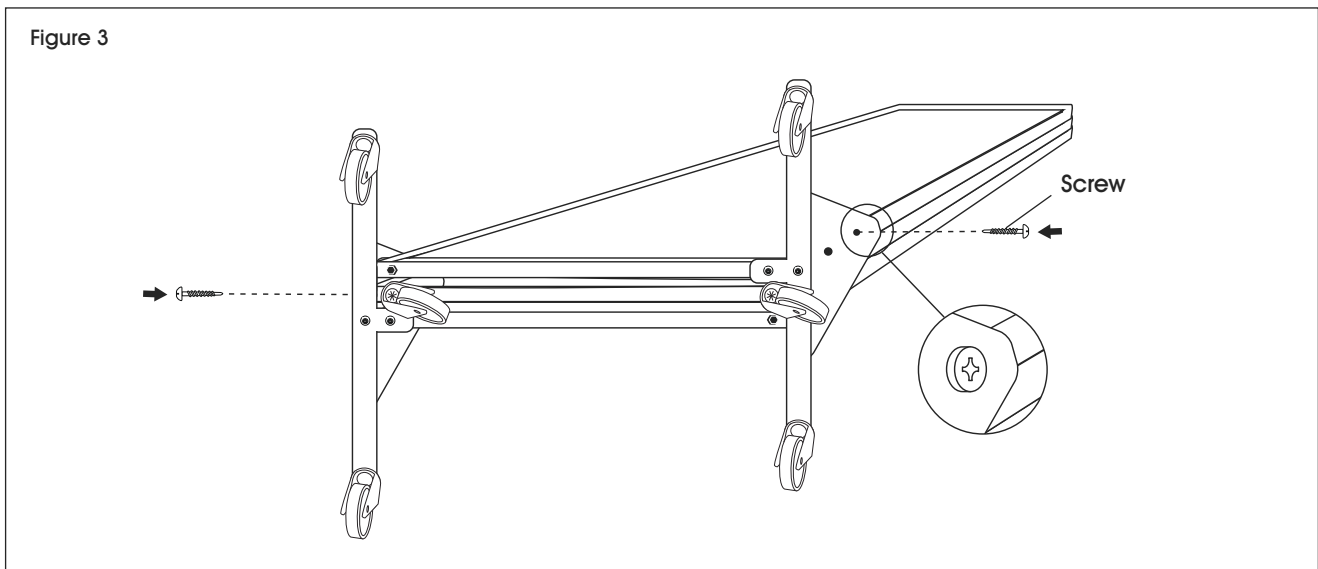

ULINE

1-800-295-5510
uline.com

ULINE H-12625

MAMPARA DE PRIVACIDAD MÓVIL

800-295-5510
uline.mx

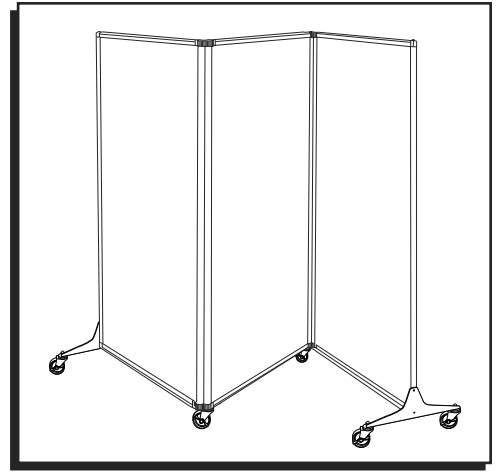

HERRAMIENTAS NECESARIAS

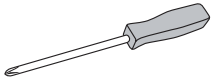

Desarmador de Cruz



Llave Allen
(incluida)

PARTES

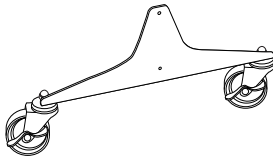

2 Patas con Ruedas



2 Tornillos



4 Pernos de Botón



4 Separadores

ENSAMBLE

 **NOTA:** La tornillería se envía fijada al panel.

1. Coloque el panel de lado. Retire dos pernos de botón y separadores del borde inferior de cada panel exterior con la llave Allen y un tornillo del lado de cada panel exterior con un desarmador de cruz. (Vea Diagrama 1)

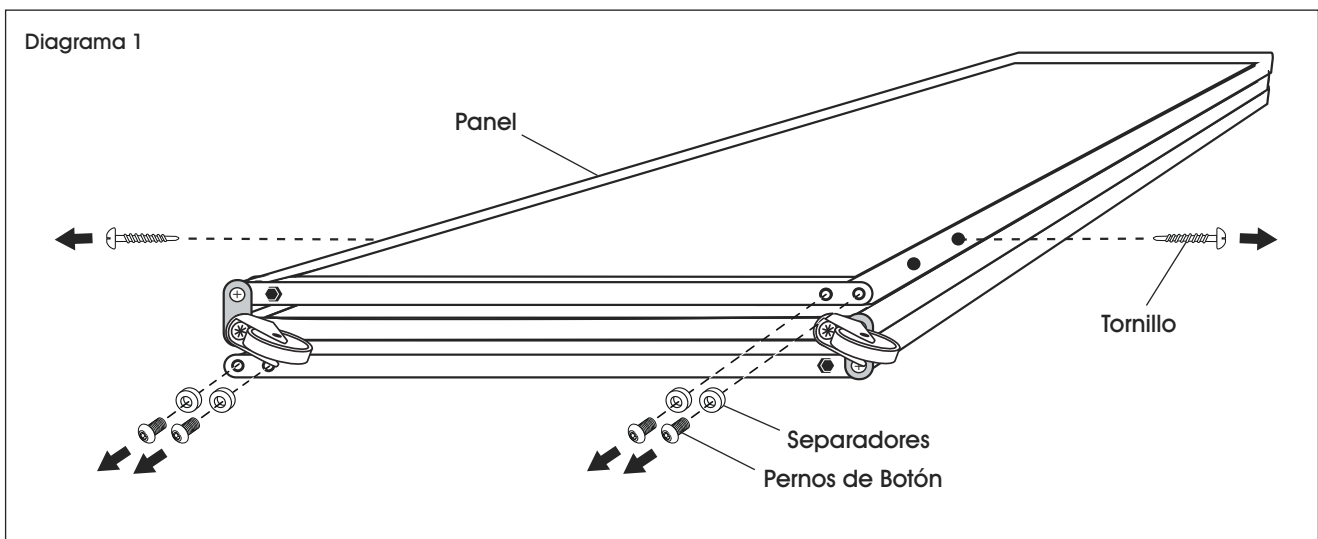

CONTINUACIÓN DE ENSAMBLE

2. Fije la base de la pata al borde inferior del panel con dos espaciadores anteriormente removidos y pernos de botón. Repita la operación en el lado opuesto. (Vea Diagrama 2)

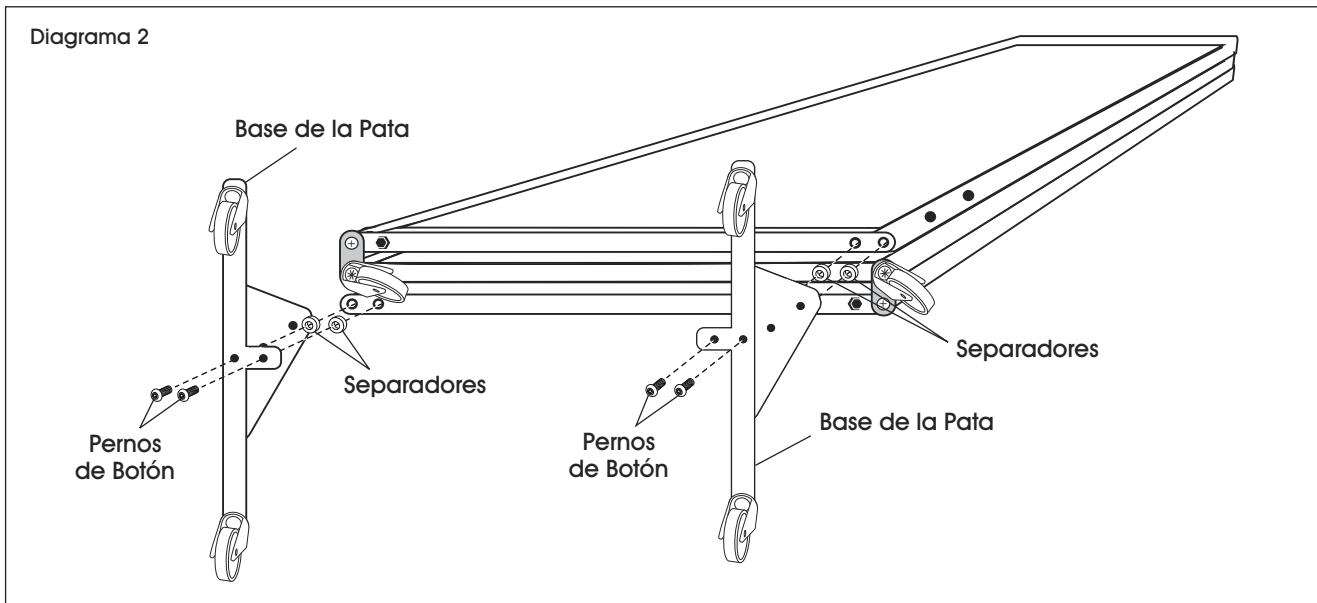

3. Fije la parte superior del lado del panel exterior con el tornillo anteriormente removido. Repita la operación en el lado opuesto. (Vea Diagrama 3) Levante el panel en posición vertical para terminar el ensamble.

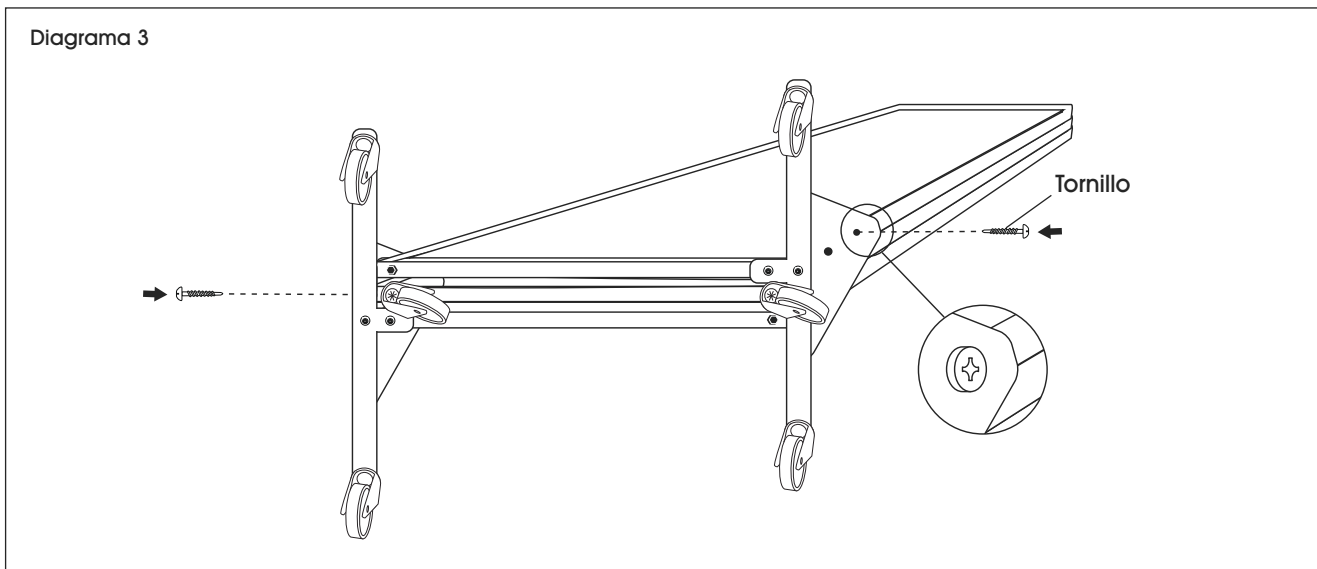

ULINE H-12625

PARAVENT MOBILE

1 800 295-5510

uline.ca

OUTILS REQUIS

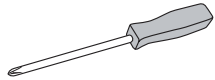

Tournevis cruciforme



Clé Allen
(incluse)

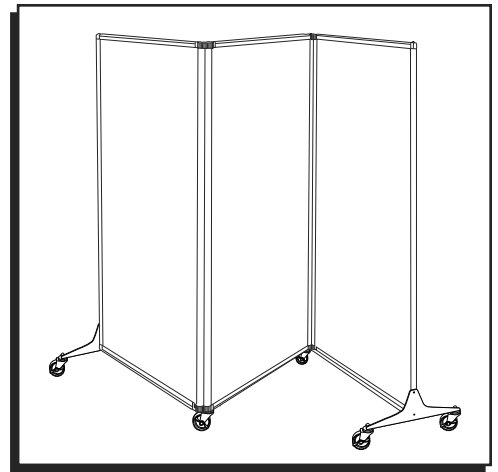

PIÈCES

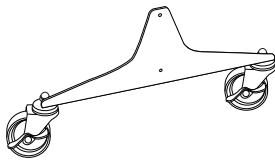

Pied avec roulettes x 2

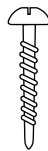

Vis x 2



Boulon à tête ronde x 4



Entretoise x 4

MONTAGE

 **REMARQUE :** Le matériel d'installation est expédié fixé au panneau.

1. Posez le panneau sur le côté. À l'aide de la clé Allen, retirez deux boulons à tête ronde et les entretoises du bord inférieur de chaque panneau extérieur, puis retirez une vis sur le côté de chaque panneau extérieur à l'aide d'un tournevis cruciforme. (Voir Figure 1)

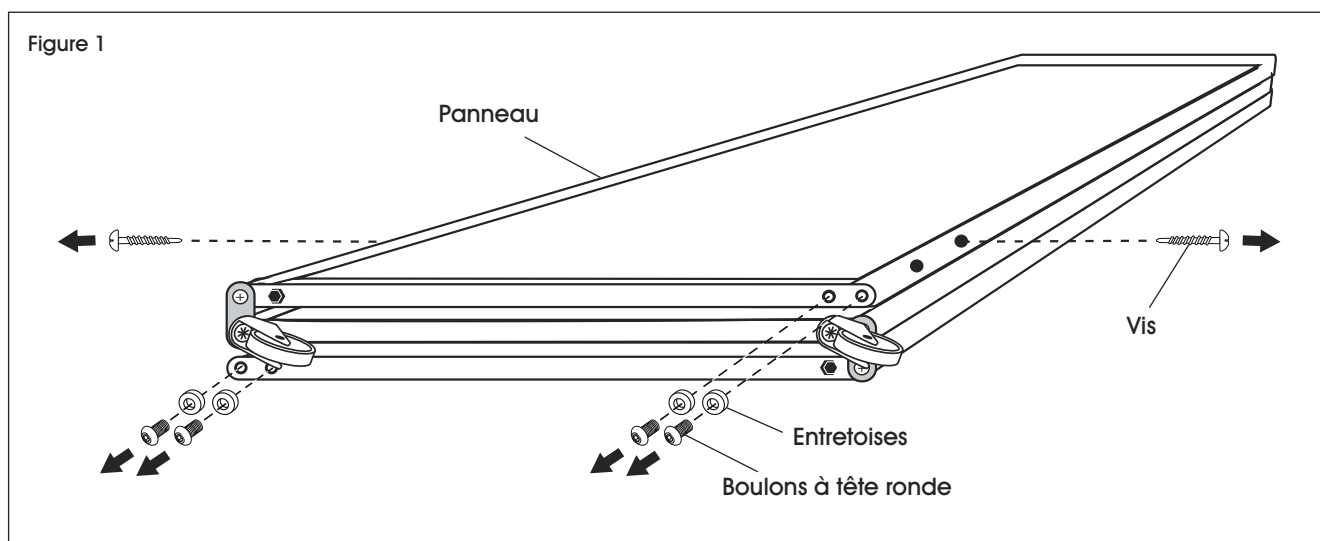

MONTAGE SUITE

- Fixez la base du pied au bord inférieur du panneau à l'aide des deux entretoises et des boulons à tête ronde retirés précédemment. Répétez l'opération de l'autre côté. (Voir Figure 2)

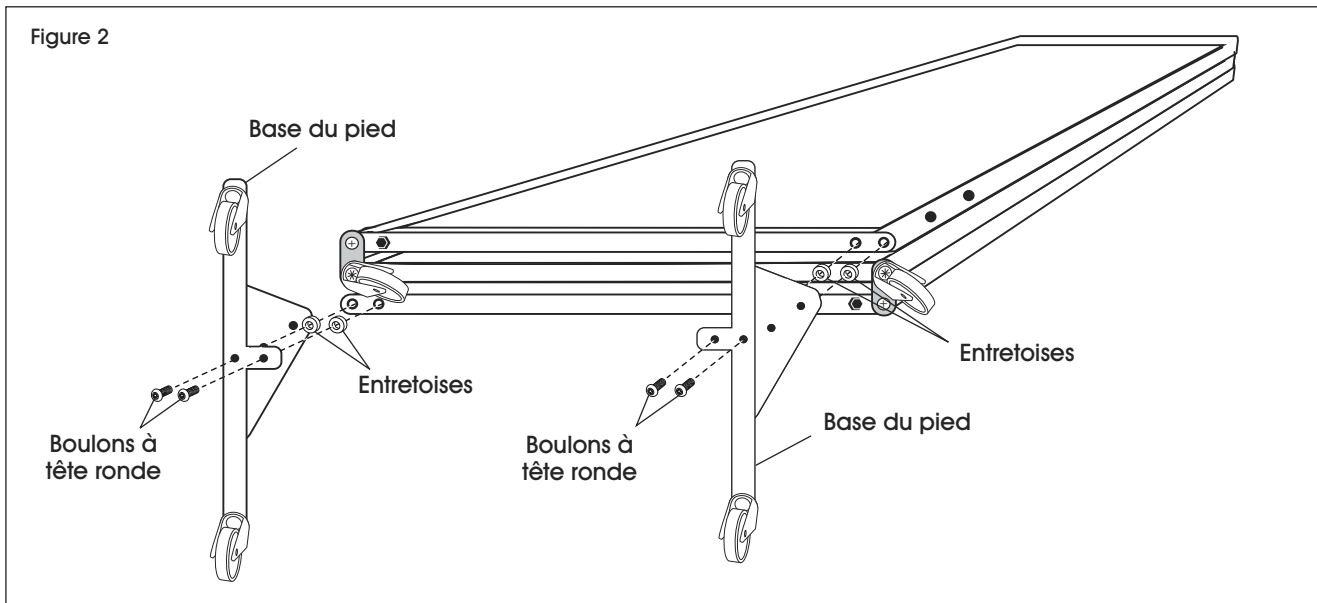

- Fixez le haut de la base du pied sur le côté du panneau extérieur à l'aide de la vis retirée précédemment. Répétez l'opération de l'autre côté. (Voir Figure 3) Redressez le panneau pour terminer le montage.

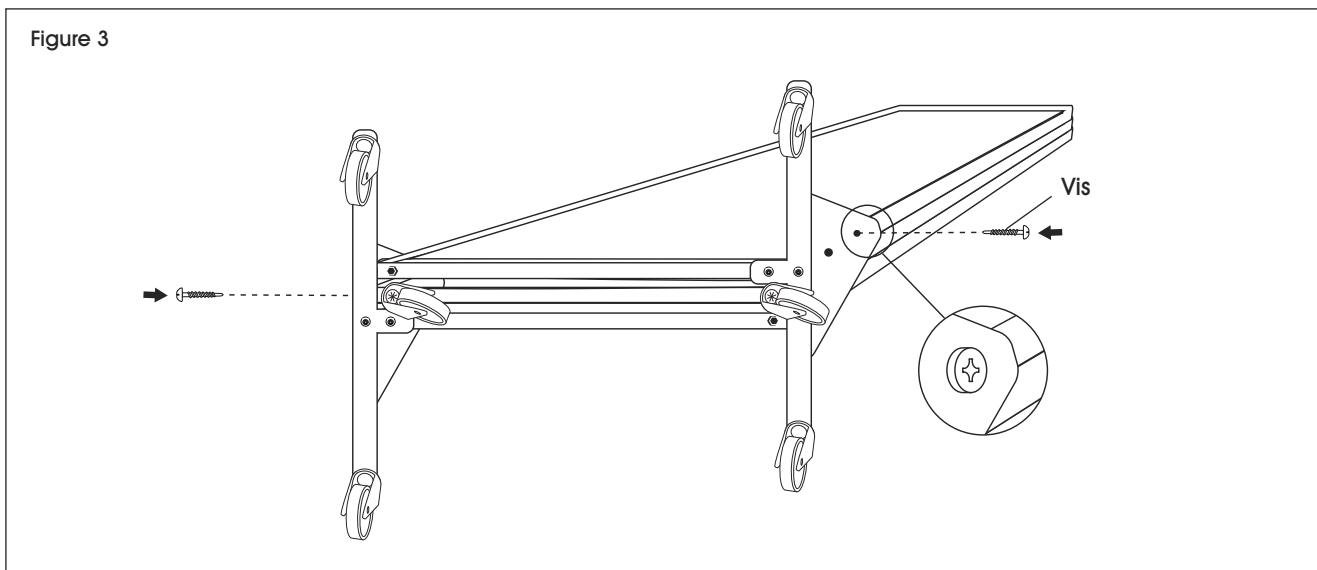

ULINE

1 800 295-5510
uline.ca