

ULINE H-1354, H-1355, H-10345 RUBBER FLOOR SQUEEGEE

1-800-295-5510
uline.com

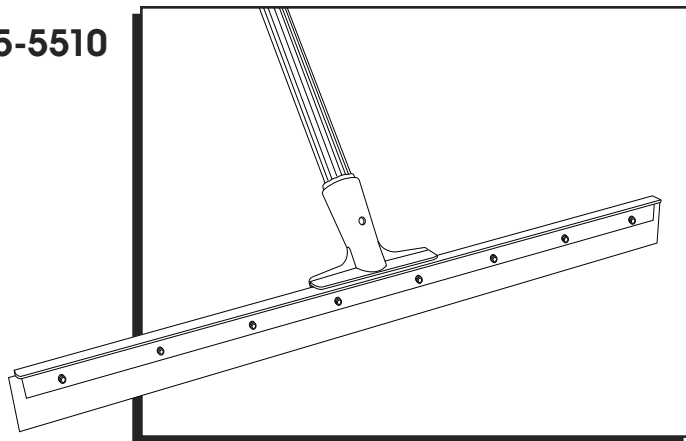

TOOL NEEDED

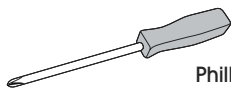

Phillips Screwdriver

INSTRUCTIONS

1. Place handle tip (threaded) securely into the squeegee head (not threaded). (See Figure 1)

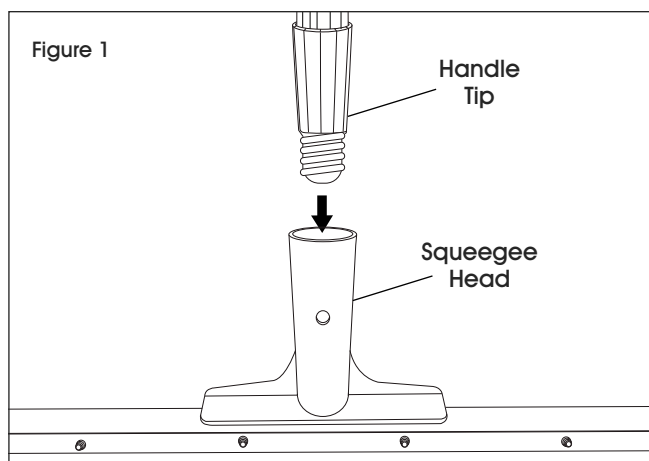

3. Place screw into the hole. Tighten screw. (See Figure 3)

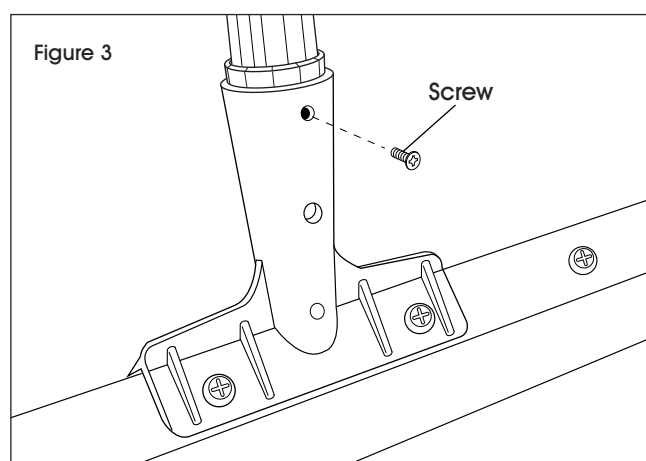

 **NOTE:** This will not click or screw in. Force handle in as far as it will go.

2. Line up the hole on the handle with the hole on the head. (See Figure 2)

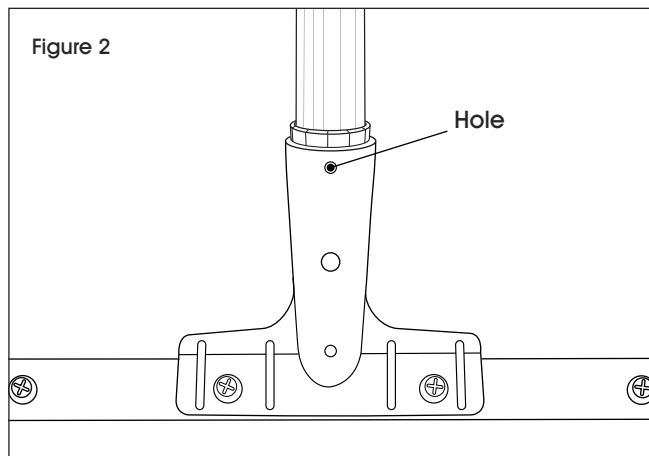

JALADOR DE GOMA PARA PISO

HERRAMIENTA NECESARIA

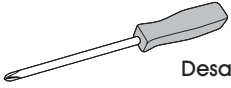

Desarmador de Cruz

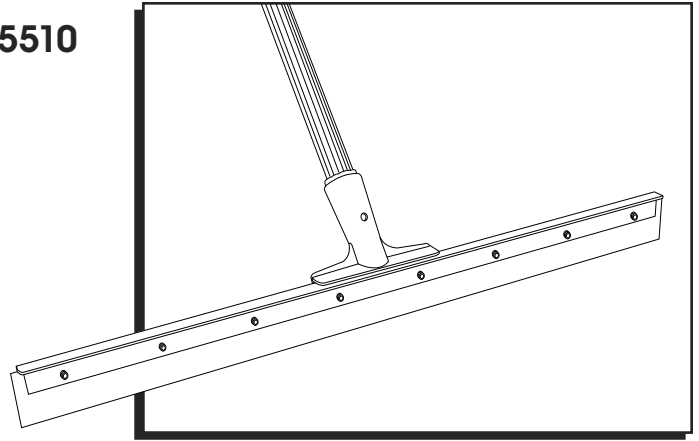

INSTRUCCIONES

1. Inserte la punta (roscada) del mango en la cabeza (no roscada) del jalador de forma segura. (Vea Diagrama 1)

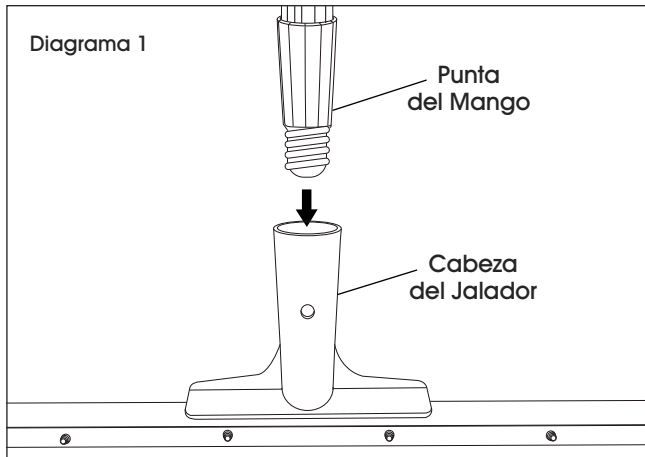

 **NOTA: No hará clic ni se enroscará. Fuerce el mango para introducirlo lo máximo posible.**

2. Alinee el orificio del mango con el orificio de la cabeza. (Vea Diagrama 2)

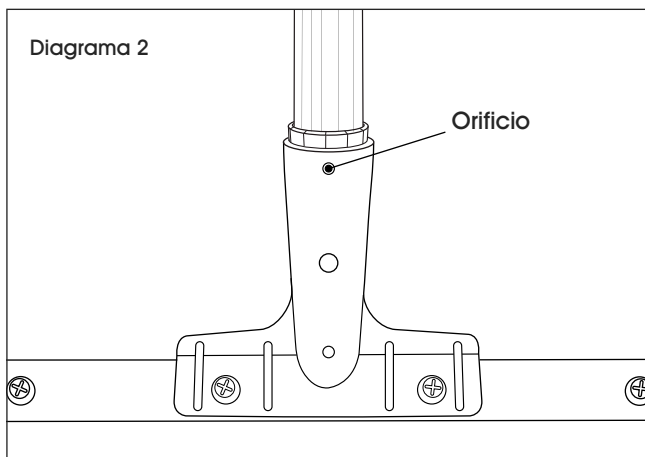

3. Inserte un tornillo en el orificio. Apriete el tornillo. (Vea Diagrama 3)

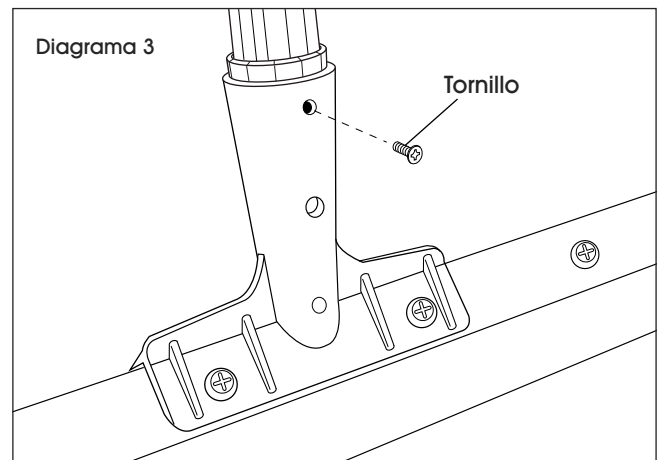

RACLETTE DE PLANCHER EN CAOUTCHOUC

OUTIL REQUIS

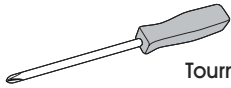

Tournevis cruciforme

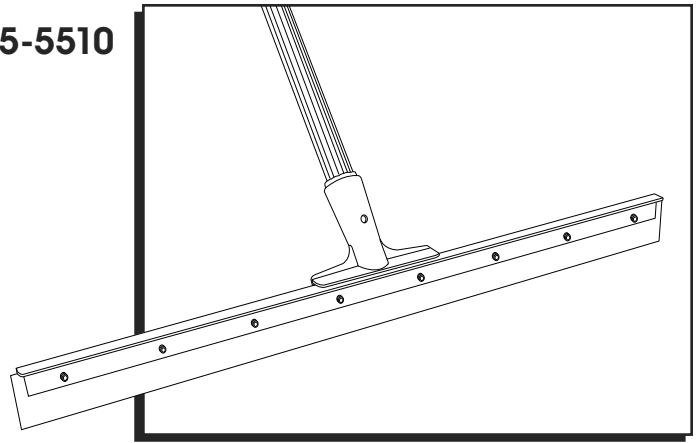

INSTRUCTIONS

1. Insérez l'extrémité de la manche (filetée) fermement dans la tête de la raclette (non filetée). (Voir Figure 1)

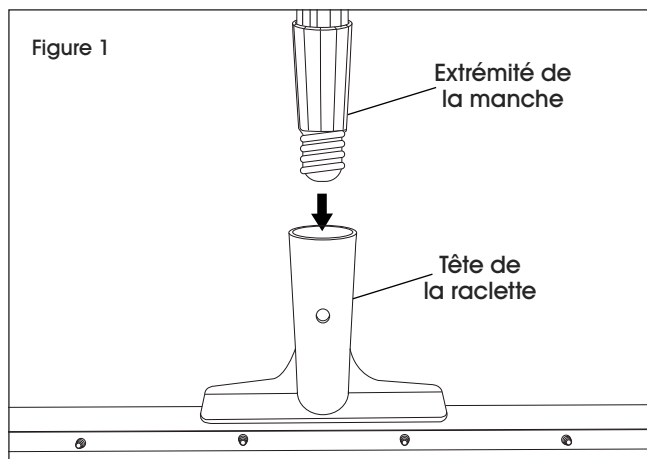

3. Insérez une vis dans le trou. Serrez la vis. (Voir Figure 3)

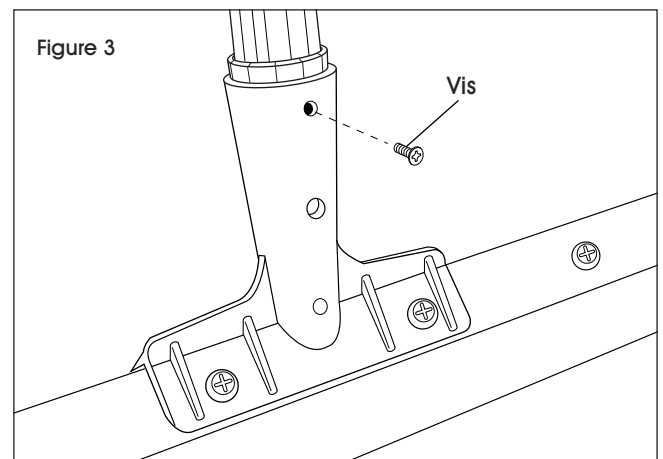

 **REMARQUE :** La manche n'est pas vissable, ni encliquetable. Insérez-la avec force le plus loin possible.

2. Alignez le trou situé sur la manche avec le trou sur la tête. (Voir Figure 2)

