

ULINE

**HEAVY-DUTY
WIRE CARTS**

1-800-295-5510
uline.com

TOOL NEEDED



Rubber Mallet

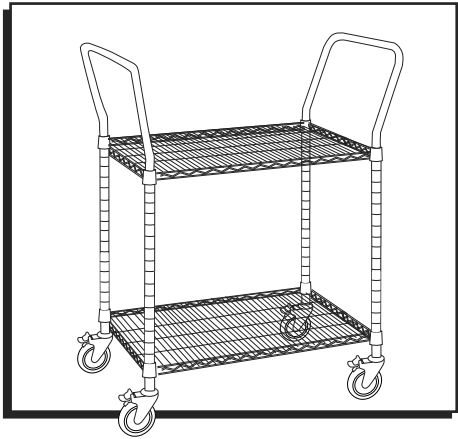

PARTS

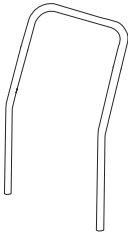

Handle x 2

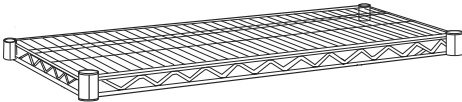

Shelf x 2



Shelf Support x 8 Sets



Caster x 4

 **NOTE:** For Three-Shelf Heavy-Duty Wire Cart Units, there will be three shelves and 12 sets of shelf supports.

ASSEMBLY

1. Slide top shelf up the posts one end at a time, handles facing out. (See Figure 1)

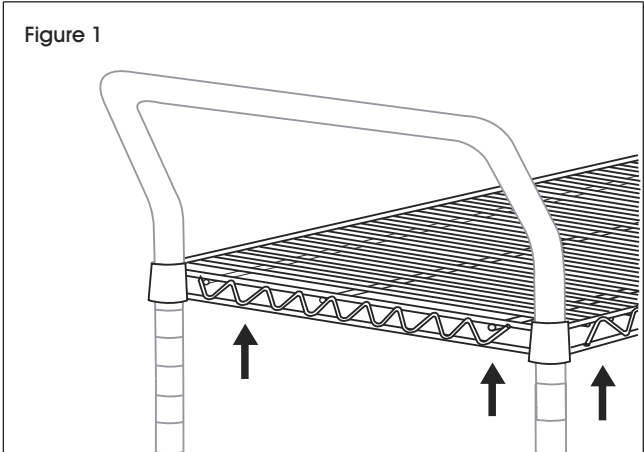

2. Snap the interlocking pieces of a shelf support (wide end down) around the post at the highest groove where shelf is to be located. Slide the support up or down until it snaps into the groove. (See Figure 2)

 **NOTE:** Make sure shelf supports are located under the shelf.

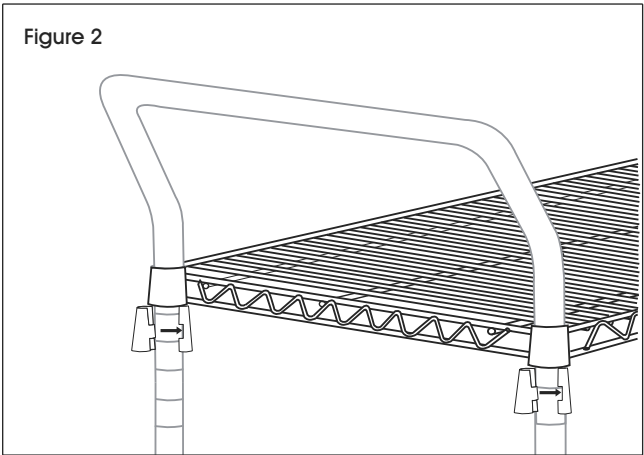

ASSEMBLY CONTINUED

3. After snapping together all of the shelf supports at the proper height, slide the shelf down over the supports to secure the shelf. (See Figure 3)
4. Repeat steps 1 through 3 to attach the remaining shelf or shelves in the same manner.

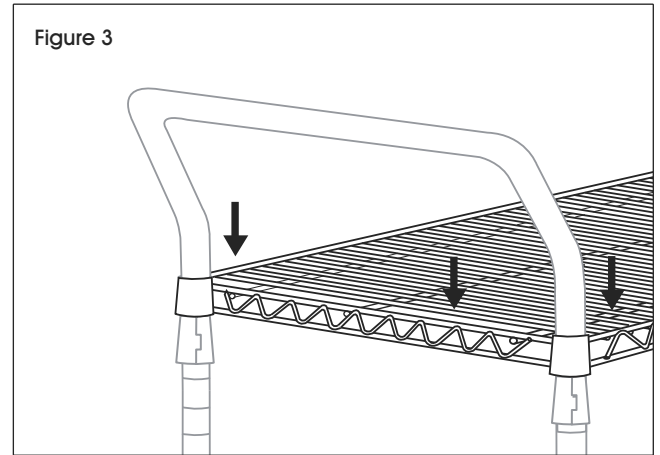

CASTER INSTALLATION

1. Make sure post is positioned as shown. (See Figure 4)
2. Engage the wheel brakes to keep casters from spinning during installation. Use a rubber mallet to tap caster stem into posts. (See Figure 4)

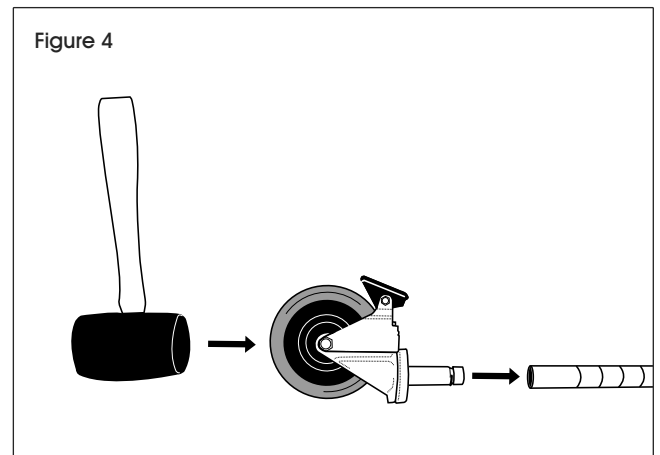

ULINE

1-800-295-5510
uline.com

ULINE

CARRITOS DE ALAMBRE PARA USO PESADO

800-295-5510
uline.mx

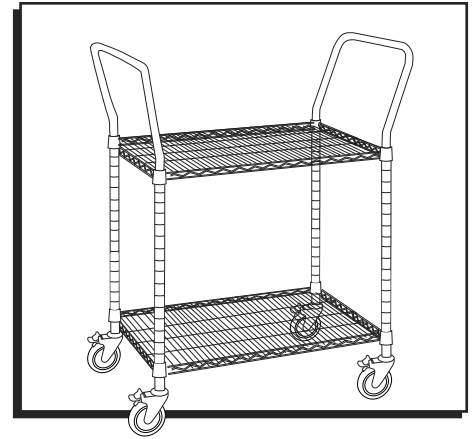

HERRAMIENTA NECESARIA



Mazo de Hule

PARTES

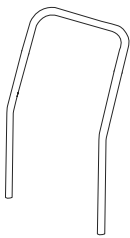

Asa x 2

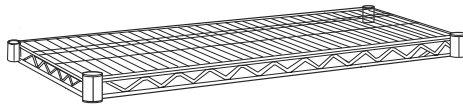

Repisa x 2



Soporte de Repisa x Set de 8



Rueda x 4



NOTA: Para unidades de Estantería de Alambre de tres repisas habrá tres repisas y 12 sets de soportes de repisa.

ENSAMBLE

1. Deslice la repisa superior por los postes hacia arriba uno a uno, con las asas mirando hacia afuera. (Vea Diagrama 1)

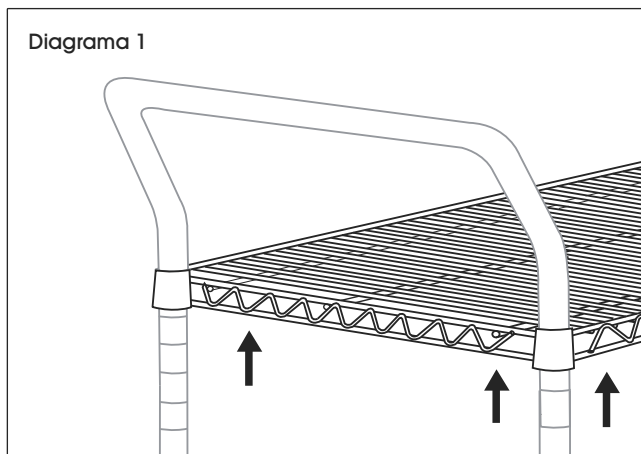

2. Coloque a presión las piezas interconectadas de un soporte de repisa (extremo amplio hacia abajo) alrededor del poste en la ranura más alta, en donde se ubicará la repisa. Deslice el soporte hacia arriba o abajo hasta que se inserte a presión en la ranura. (Vea Diagrama 2)



NOTA: Asegúrese de que los soportes para las repisas estén colocados debajo de la repisa.

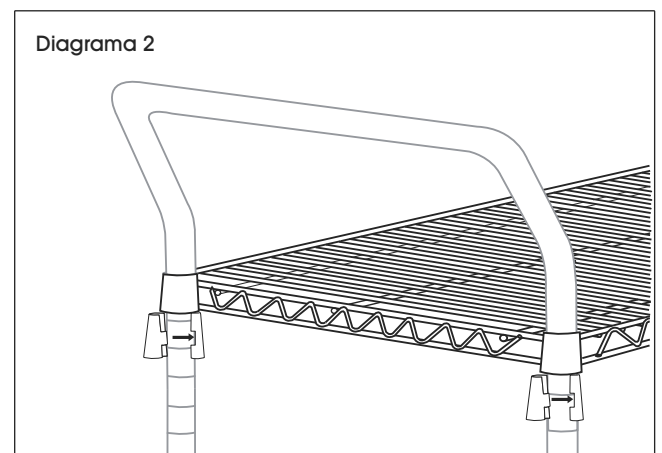

CONTINUACIÓN DE ENSAMBLE

3. Tras unir todos los soportes para las repisas a la altura adecuada, deslice la repisa hacia abajo por encima de los soportes para fijar la repisa. (Vea Diagrama 3)
4. Repita los pasos del 1 al 3 para fijar el resto de repisas de la misma forma.

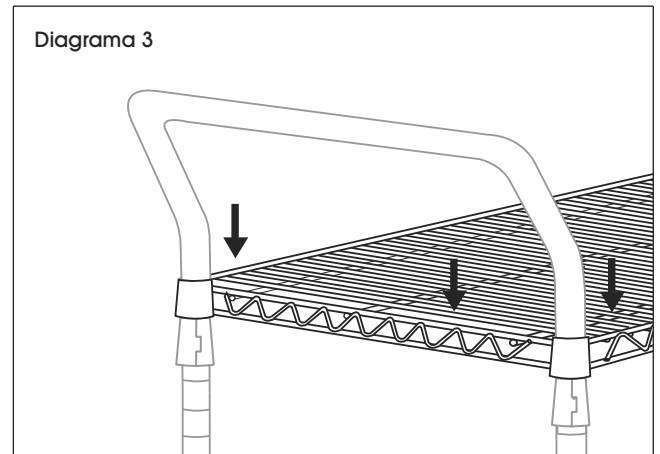

INSTALACIÓN DE LAS RUEDAS

1. Asegúrese de que el poste esté posicionado como se indica. (Vea Diagrama 4)
2. Active los frenos para evitar que las ruedas se giren durante la instalación. Utilice un mazo de hule para introducir los vástagos de las ruedas en los postes. (Vea Diagrama 4)

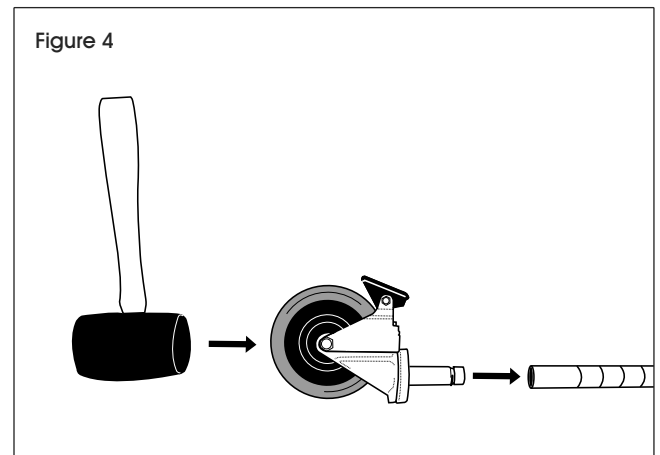

ULINE

800-295-5510
uline.mx

ULINE

CHARIOTS ROBUSTES EN FIL DE MÉTAL

1-800-295-5510

uline.ca

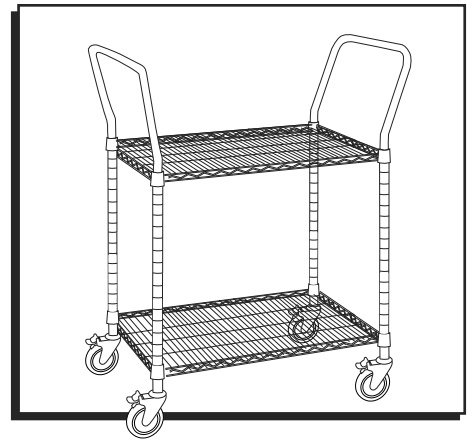

OUTILS REQUIS



Maillet en caoutchouc

PIÈCES

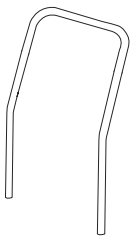

Poignée x 2

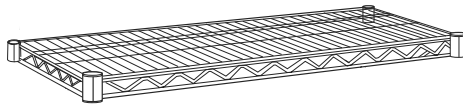

Tablette x 2



Ensemble de support de tablette x 8



Roulette x 4



REMARQUE : Trois tablettes et 12 ensembles de supports de tablette seront disponibles pour les chariots robustes en fil de métal.

MONTAGE

1. Faites glisser la tablette supérieure vers le haut sur les montants, une extrémité à la fois, les poignées vers l'extérieur. (Voir Figure 1)

Figure 1

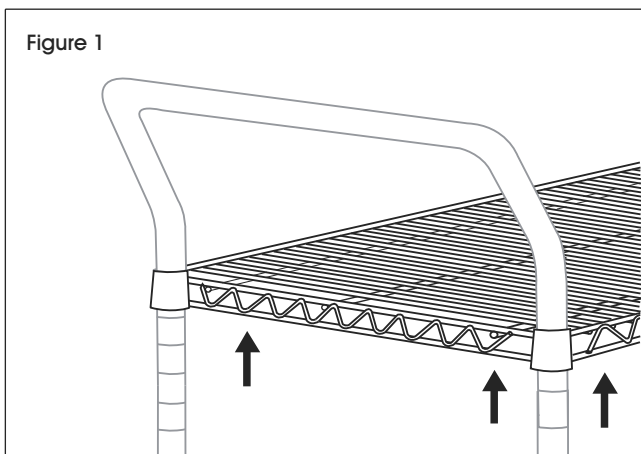

2. Enclenchez les pièces emboîtables d'un support de tablette (l'extrémité la plus large vers le bas) autour du montant, au niveau de la rainure la plus élevée à l'endroit où la tablette doit être placée. Faites glisser le support vers le haut ou vers le bas jusqu'à ce qu'il s'enclenche dans la rainure. (Voir Figure 2)



REMARQUE : Assurez-vous que les supports de tablette sont situés sous la tablette.

Figure 2

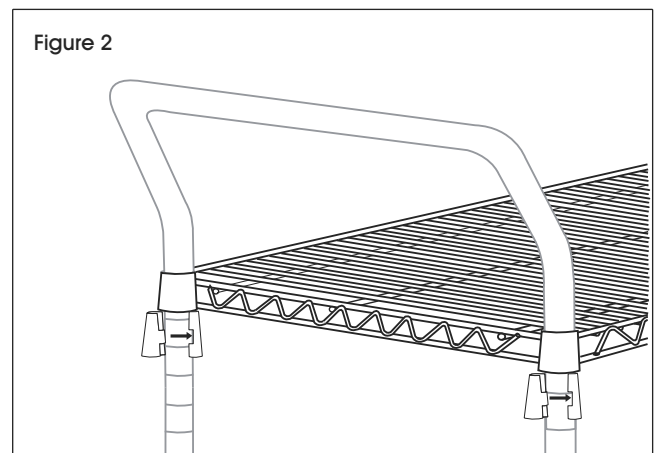

MONTAGE SUITE

3. Lorsque tous les supports de tablette sont enclenchés à la bonne hauteur, faites glisser la tablette vers le bas sur les supports pour fixer la tablette. (Voir Figure 3)
4. Répétez les étapes 1 à 3 pour fixer la ou les tablettes restantes de la même manière.

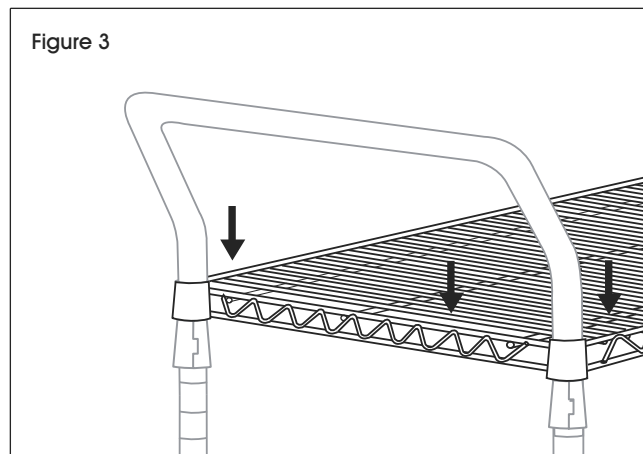

INSTALLATION DES ROULETTES

1. Assurez-vous que le montant est placé comme illustré. (Voir Figure 4)
2. Enclenchez le frein des roulettes pour les empêcher de tourner pendant l'installation. Utilisez un maillet en caoutchouc pour insérer la tige des roulettes dans les montants. (Voir Figure 4)

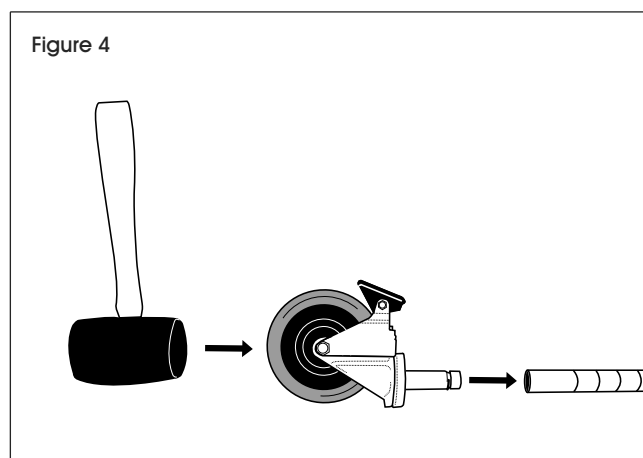

ULINE

1-800-295-5510
uline.ca