

# ULINE H-156, H-165 INDUSTRIAL TOP LOADER TAPE DISPENSER

1-800-295-5510  
uline.com

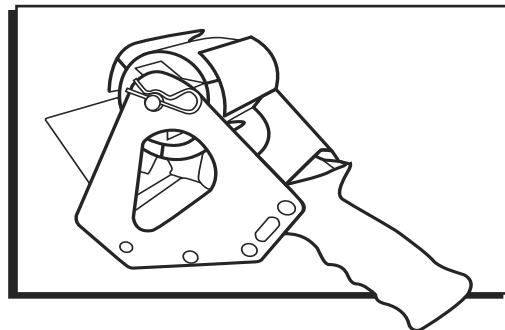

## PARTS

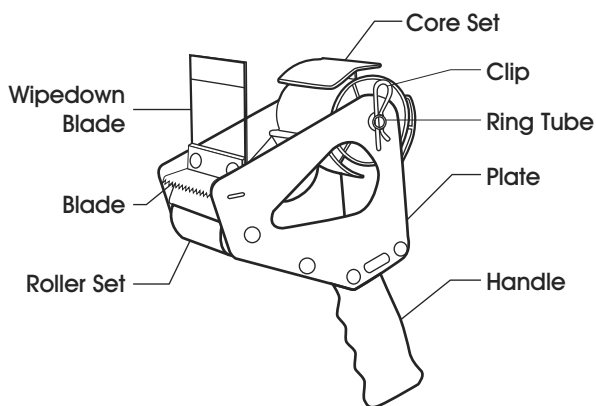

## LOADING INSTRUCTIONS

1. Remove clip. (See Figure 1)
2. Pull out ring tube. (See Figure 2)
3. Remove core set by pulling it away from dispenser. (See Figure 3)
4. Load tape roll onto core set. (See Figure 4)
5. Replace core set (with tape roll) by pressing it into dispenser. (See Figure 5)
6. Replace ring tube into core. (See Figure 6)
7. Replace clip. (See Figure 7)
8. Thread tape through dispenser with adhesive side down. (See Figure 8)

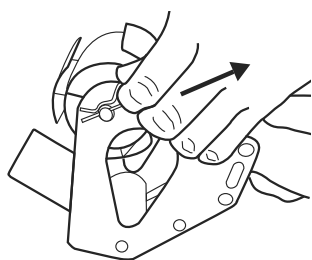

Figure 1

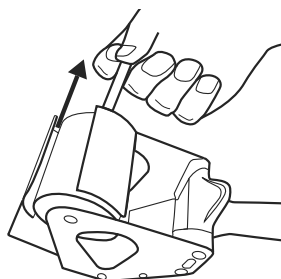

Figure 2

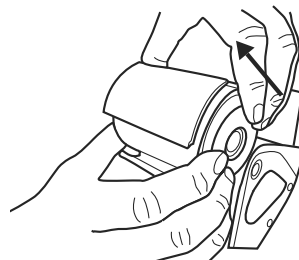

Figure 3

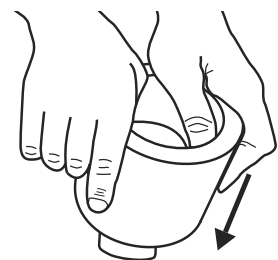

Figure 4

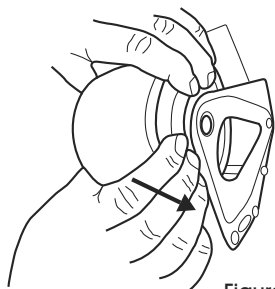

Figure 5

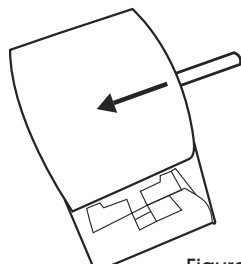

Figure 6

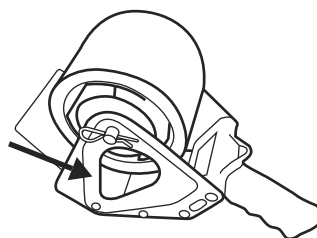

Figure 7

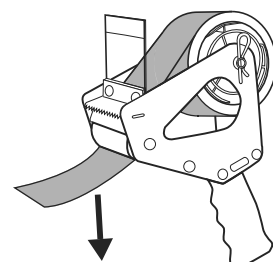
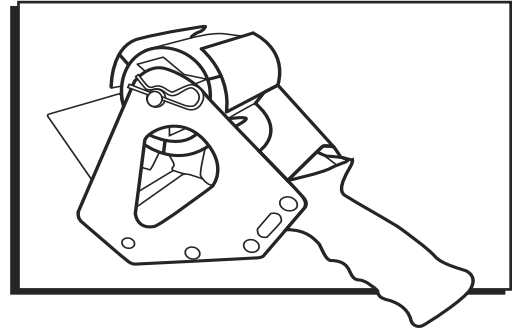

Figure 8

# ULINE H-156, H-165

## DESPACHADOR INDUSTRIAL DE CINTA DE CARGA SUPERIOR

800-295-5510  
uline.mx



### PARTES

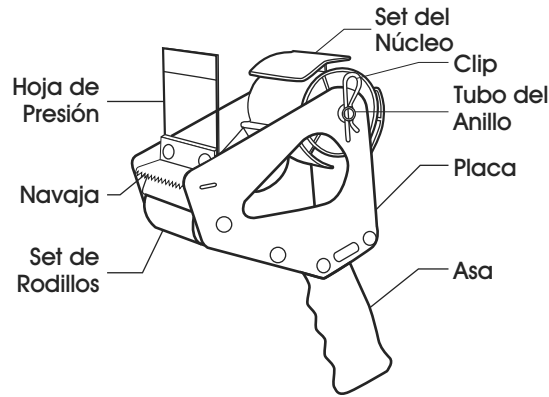

### INSTRUCCIONES DE CARGA

1. Quite el clip. (Vea Diagrama 1)
2. Jale el tubo del anillo para sacarlo. (Vea Diagrama 2)
3. Retire el set del núcleo jalándolo del despachador. (Vea Diagrama 3)
4. Cargue la cinta en el set del núcleo. (Vea Diagrama 4)
5. Reemplace el set del núcleo (con el rollo de cinta) presionándolo en el despachador. (Vea Diagrama 5)
6. Reemplace el tubo del anillo en el núcleo. (Vea Diagrama 6)
7. Reemplace el clip. (Vea Diagrama 7)
8. Inserte la cinta a través del despachador con la cara adhesiva apuntando hacia abajo. (Vea Diagrama 8)



Diagrama 1



Diagrama 2

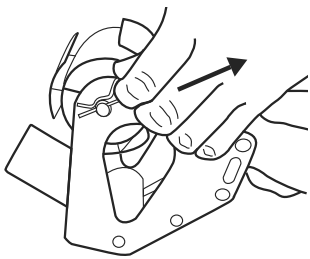

Diagrama 3

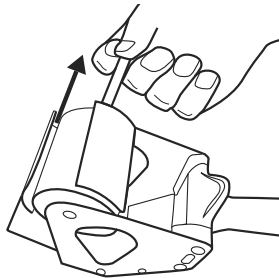

Diagrama 4

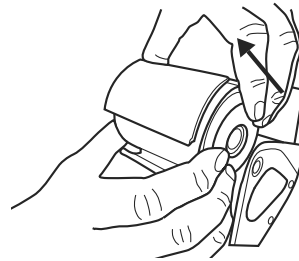

Diagrama 5

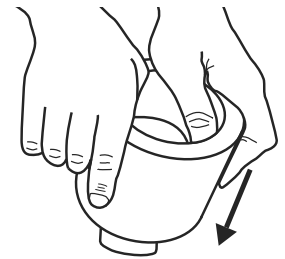

Diagrama 6

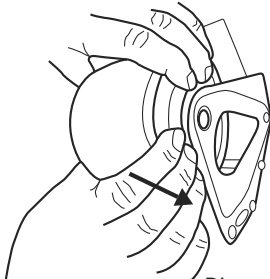

Diagrama 7

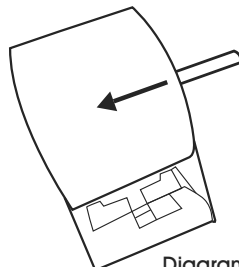

Diagrama 8

**ULINE H-156, H-165**  
**DÉVIDOIR DE RUBAN**  
**ADHÉSIF INDUSTRIEL**  
**À CHARGEMENT PAR**  
**LE HAUT**

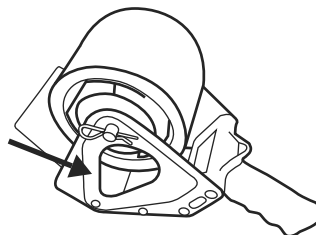
1-800-295-5510  
 uline.ca

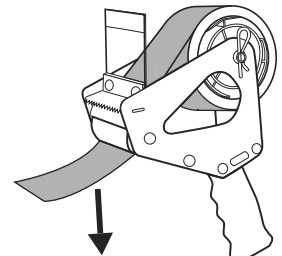
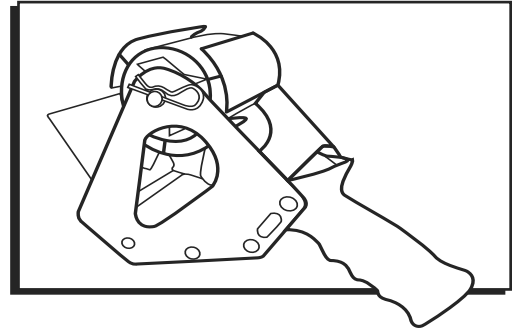

**PIÈCES**

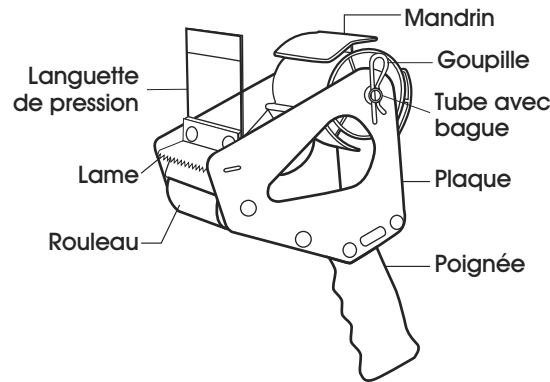

**INSTRUCTIONS DE CHARGEMENT**

1. Retirez la goupille. (Voir Figure 1)
2. Retirez le tube doté d'une bague. (Voir Figure 2)
3. Enlevez le mandrin du dévidoir en le tirant vers vous. (Voir Figure 3)
4. Installez le rouleau de ruban adhésif sur le mandrin. (Voir Figure 4)
5. Remettez le mandrin (chargé du rouleau de ruban adhésif) en place dans le dévidoir en le poussant. (Voir Figure 5)
6. Réintroduisez le tube doté d'une bague dans le mandrin. (Voir Figure 6)
7. Réinsérez la goupille. (Voir Figure 7)
8. Engagez l'extrémité du ruban adhésif dans le dévidoir, le côté adhésif orienté vers le bas. (Voir Figure 8)

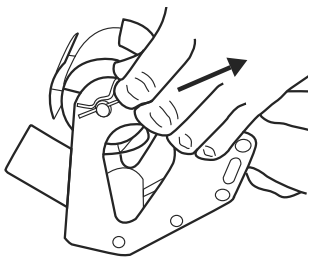

Figure 1

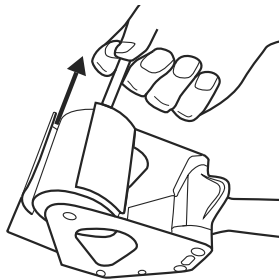

Figure 2

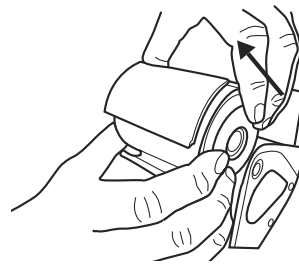

Figure 3

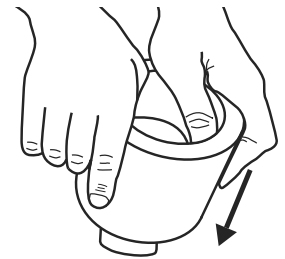

Figure 4

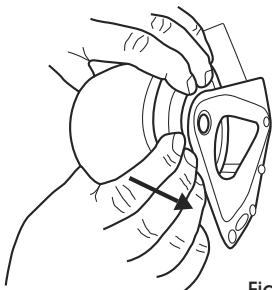

Figure 5

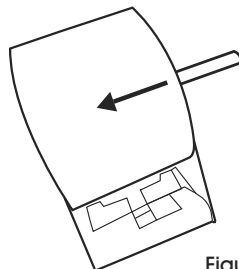

Figure 6

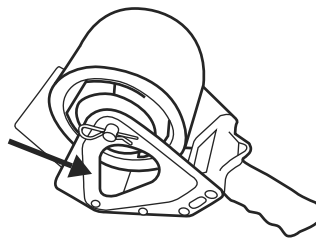

Figure 7

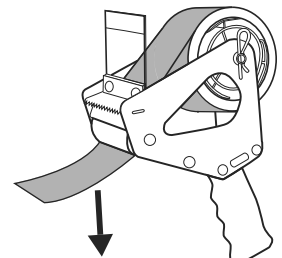

Figure 8