

ULINE H-1586, H-1587 POLY CORD STRAPPING TENSIONERS

1-800-295-5510
uline.com

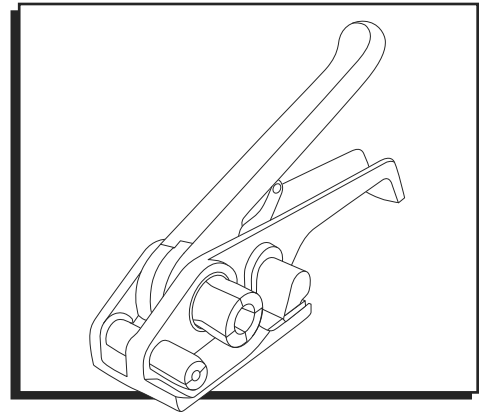

OPERATION

1. Slide strap through buckle as shown. (See Figure 1)

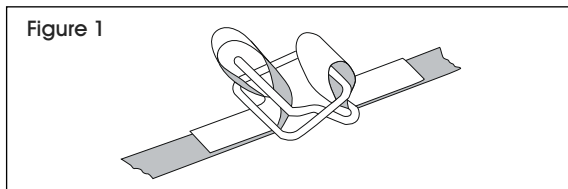

2. Put strap and buckle around package and manually tighten the strap. (See Figure 2)

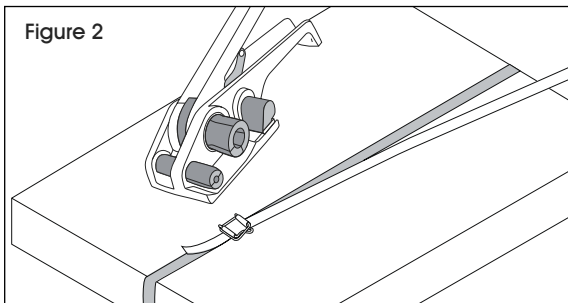

3. Depress tension lever with right hand. Place strap under the gripper so that it touches the housing with the right hand edge. Release tension lever. (See Figure 3)

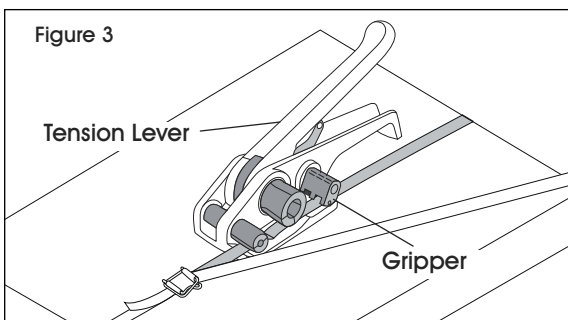

4. Insert upper strap into slot of cutter mechanism and the windlass. Hold tool and strap with your left hand and move the tension lever forward and backward until the strap is tensioned. (See Figure 4)

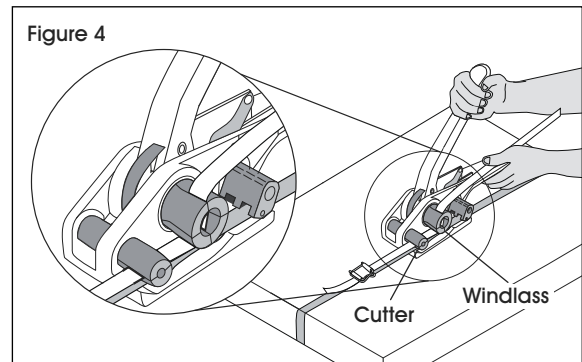

5. Depress the tension lever completely until strap is cut. Pivot the tensioner away from the strap. (See Figure 5)

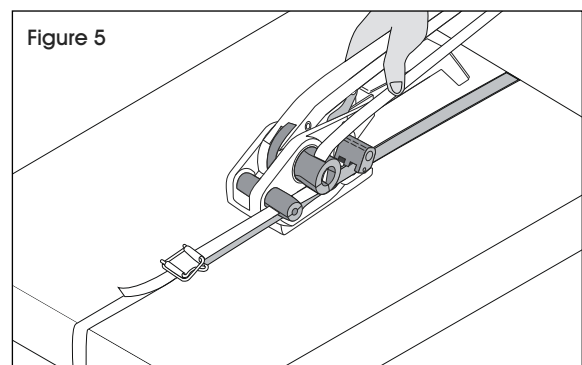

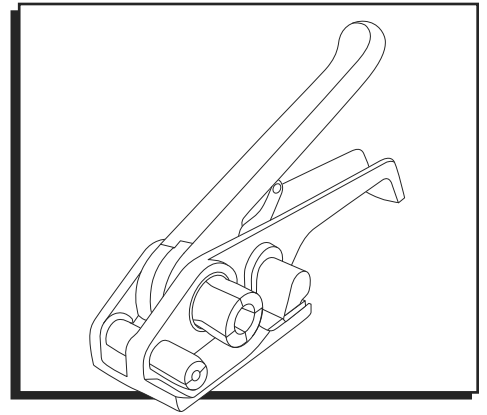
**FUNCIONAMIENTO**

1. Deslice la correa a través de la hebilla como se muestra. (Vea Diagrama 1)

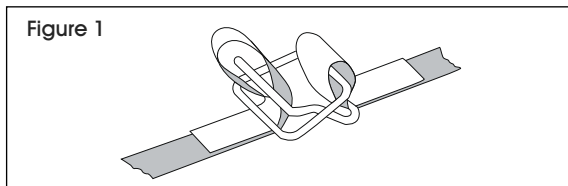

2. Coloque la correa y la hebilla alrededor del paquete y tense la correa manualmente. (Vea Diagrama 2)

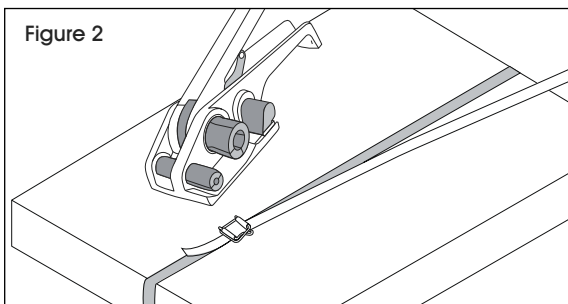

3. Con la mano derecha agarre la herramienta y apriete la palanca tensionadora. Coloque la correa debajo de la placa de agarre de forma que toque la carcasa con el borde derecho. Libere la palanca tensionadora. (Vea Diagrama 3)

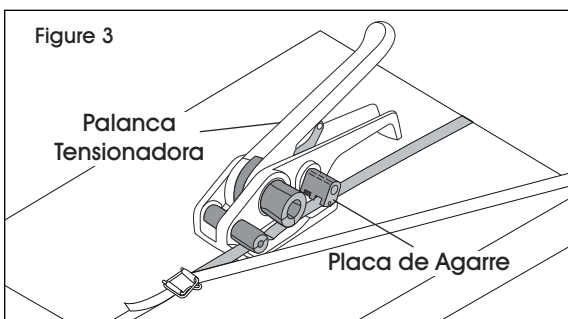

4. Inserte la correa superior en la ranura del mecanismo de corte y el molinete. Sostenga la herramienta y la correa con su mano izquierda y mueva la palanca tensionadora hacia adelante y hacia atrás hasta que la correa quede tensa. (Vea Diagrama 4)

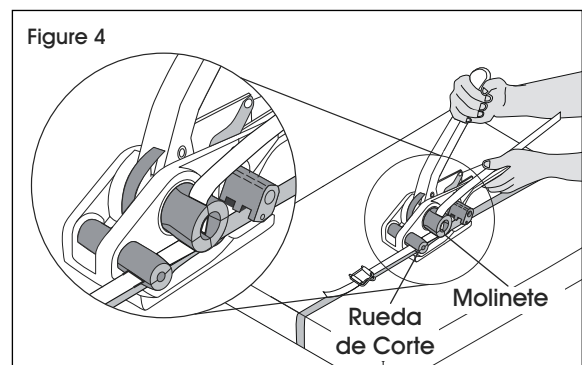

5. Apriete completamente la palanca tensionadora hasta que se corte la correa. Gire la herramienta en dirección opuesta a la correa. (Vea Diagrama 5)

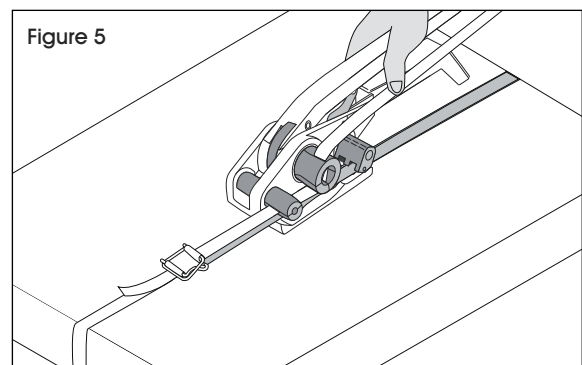

ULINE H-1586, H-1587

TENDEURS DE CERCLAGE EN CORDON DE POLYESTER

800-295-5510
uline.ca

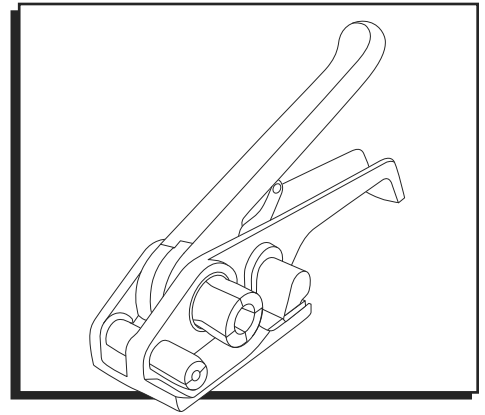

FONCTIONNEMENT

1. Faites glisser le cerclage par la boucle comme illustré. (Voir Figure 1)

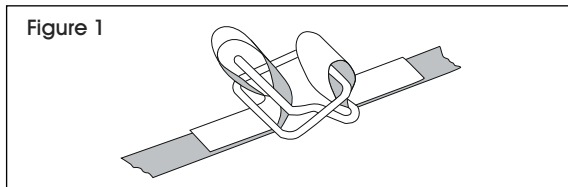

2. Placez le cerclage et la boucle autour du paquet et serrez manuellement le cerclage. (Voir Figure 2)

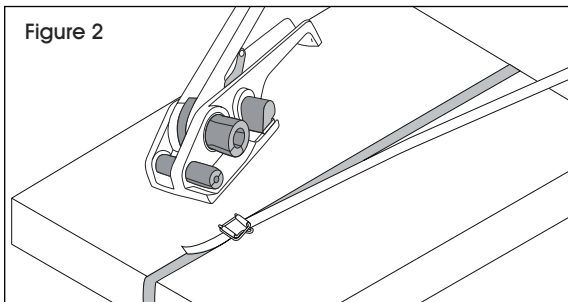

3. Prenez le tendeur de la main droite et relâchez le levier à tension. Placez le cerclage sous la pince pour qu'elle touche le boîtier du rebord de la main droite. Relâchez le levier à tension. (Voir Figure 3)

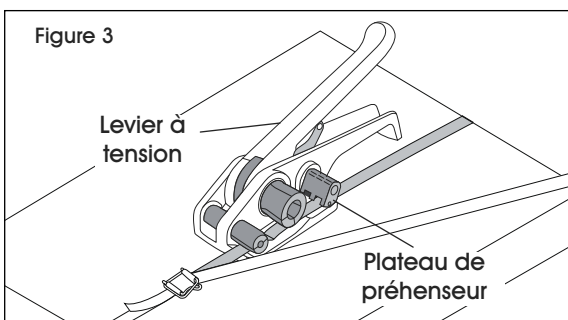

4. Insérez la partie supérieure du cerclage dans la fente du mécanisme de coupe et du bourriquet. Tenez l'outil et le cerclage de la main gauche et déplacez le levier à tension vers l'avant et l'arrière jusqu'à ce que le cerclage soit tendue. (Voir Figure 4)

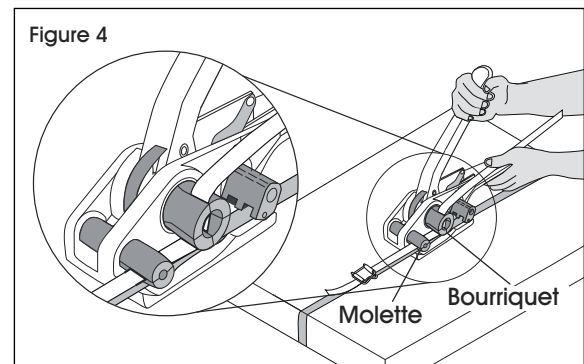

5. Relâchez le levier à tension complètement jusqu'à ce que le cerclage soit coupé. Faites pivoter le tendeur à l'écart du cerclage. (Voir Figure 5)

