

ULINE H-1628
EURO HEAT TREATED
EXPORT PALLET

1-800-295-5510
 uline.com

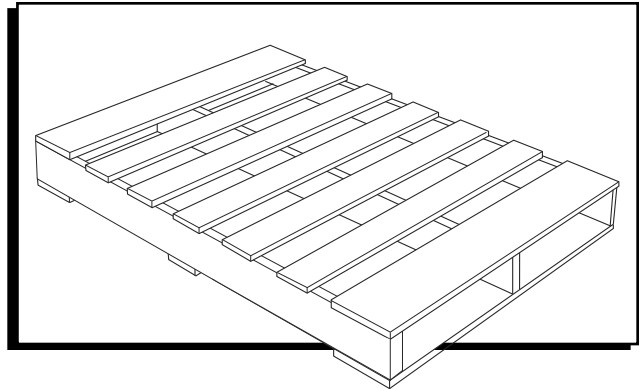

PRODUCT DIMENSIONS

TOP VIEW

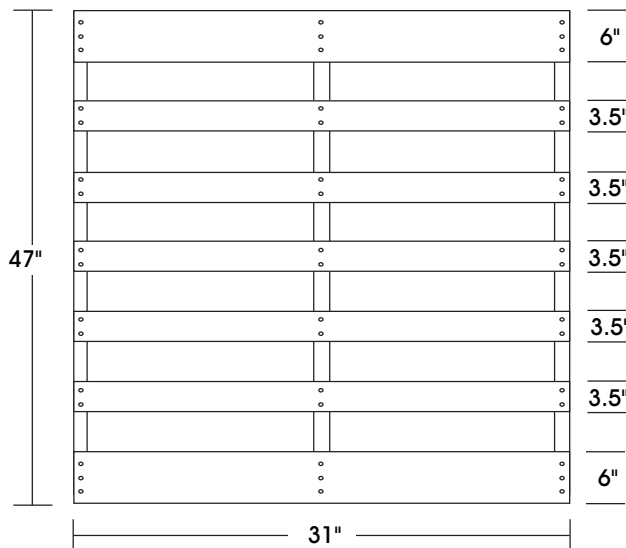

SIDE VIEW

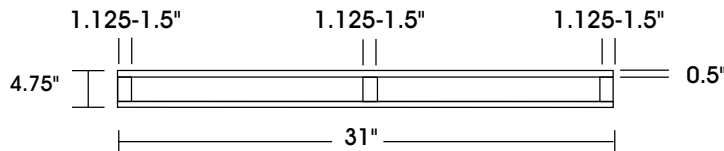
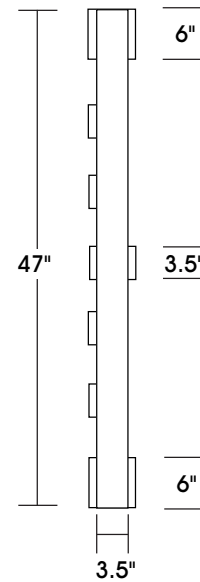

END VIEW

SPECIFICATIONS

MODEL #	DIMENSIONS		HEIGHT		TRAILER QUANTITY		WEIGHT CAPACITY		WEIGHT
	L	W	FORK	OVERALL	48'	53'	FLOOR	FORK	
H-1628	47"	31"	3.5"	4.75"	680	760	10,346 lbs.	5,000 lbs.	32 lbs.

ULINE H-1628

800-295-5510

uline.mx

**TARIMA EURO
PARA EXPORTACIÓN
TRATADA CON CALOR**

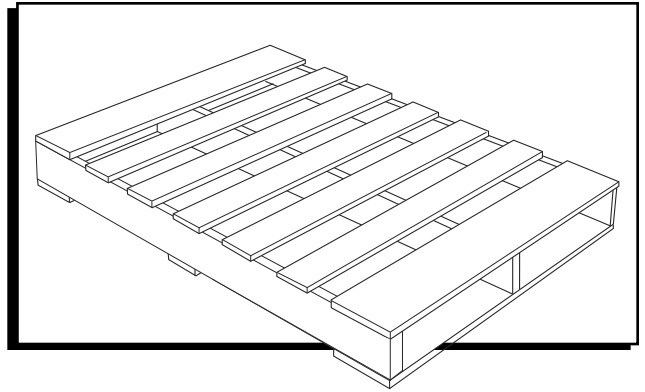

DIMENSIONES DEL PRODUCTO

VISTA SUPERIOR

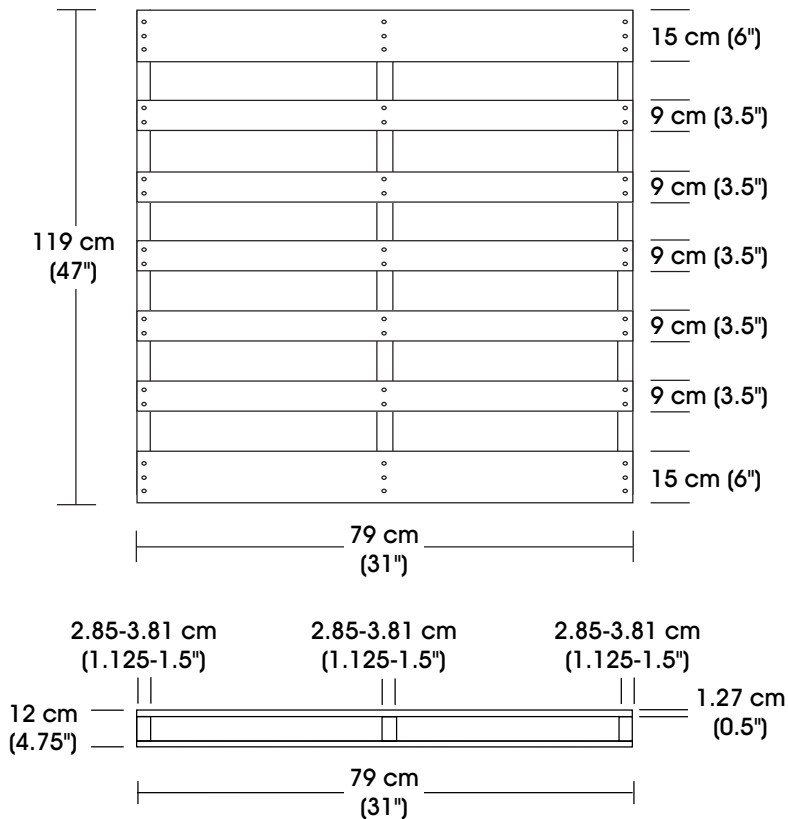

VISTA DEL EXTREMO

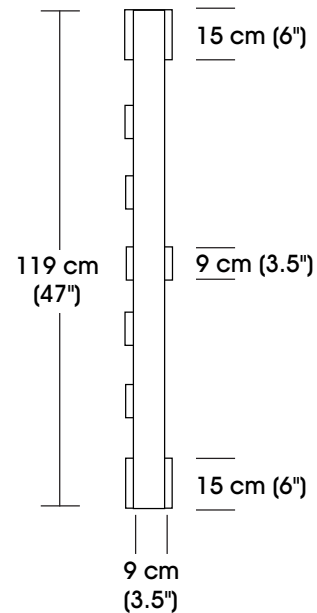

VISTA LATERAL

ESPECIFICACIONES

MODELO NO.	DIMENSIONES		ALTO		CANTIDAD POR TRÁILER		CAPACIDAD DE PESO		PESO
	LARGO	ANCHO	HORQUILLA	GENERAL	14.6 m (48')	16.15 m (53')	PISO	HORQUILLA	
H-1628	119 cm (47")	79 cm (31")	9 cm (3.5")	12 cm (4.75")	680	760	4,692 kg (10,346 lbs.)	2,267 kg (5,000 lbs.)	14 kg (32 lbs.)

ULINE H-1628

1 800 295-5510

uline.ca

**PALETTE
D'EXPORTATION
THERMIQUEMENT TRAITÉE
HOMOLOGUÉE POUR L'UE**

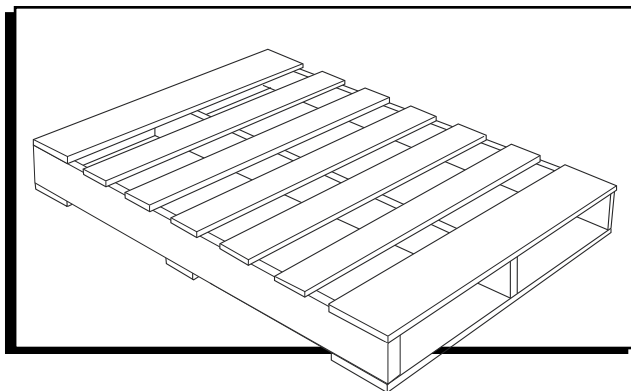

DIMENSIONS DU PRODUIT

VUE DE DESSUS

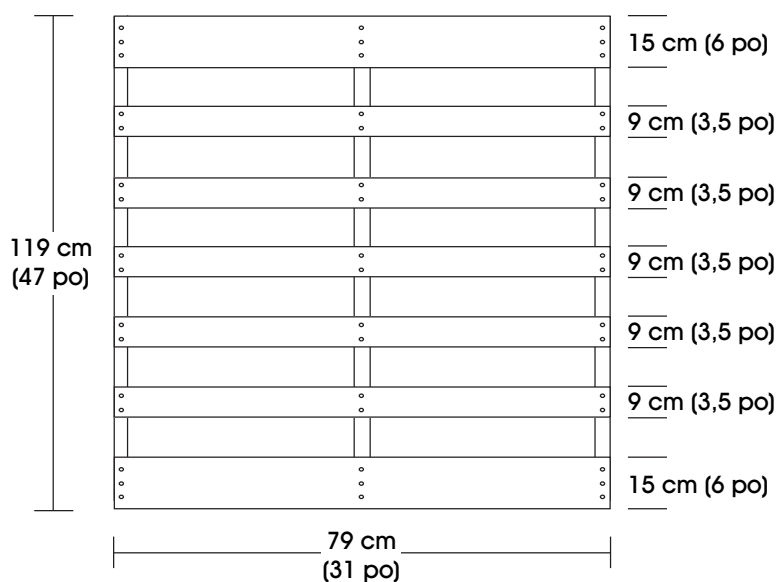

VUE DE L'EXTRÉMITÉ

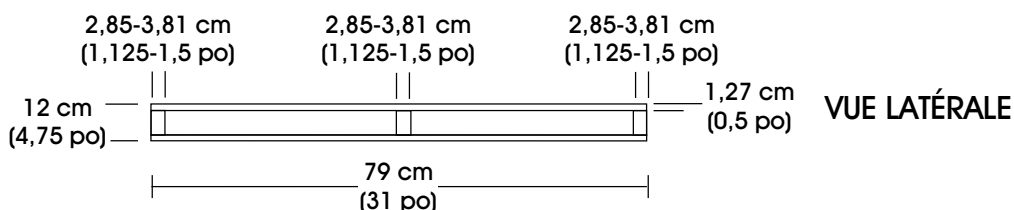
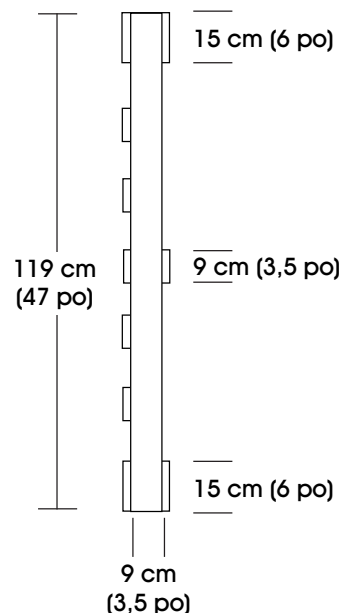

VUE LATÉRALE

SPÉCIFICATIONS

N° DE MODÈLE	DIMENSIONS		HAUTEUR		QUANTITÉ PAR REMORQUE		CAPACITÉ PONDÉRALE		POIDS
	LONG.	LARG.	FOURCHE	TOTALE	14,6 m (48 pi)	16,15 m (53 pi)	PLANCHER	FOURCHE	
H-1628	119 cm (47 po)	79 cm (31 po)	9 cm (3,5 po)	12 cm (4,75 po)	680	760	4 692 kg (10 346 lb)	2 267 kg (5 000 lb)	14 kg (32 lbs.)