

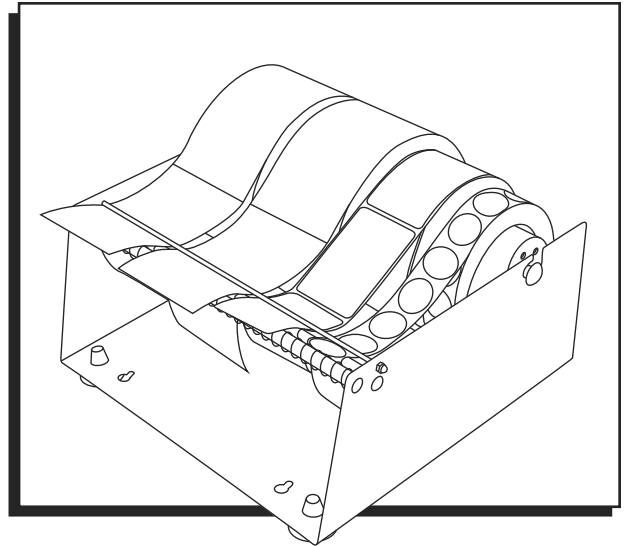

ULINE H-17, H-587 DELUXE LABEL DISPENSER

1-800-295-5510
uline.com



INSTRUCTIONS

1. Remove the first few labels on the roll and feed liner under the first bar. (See Figure 1)

 **NOTE:** Use the larger plastic roller when label core is larger than 2" and use the smaller aluminum roller when label core is smaller than 2".

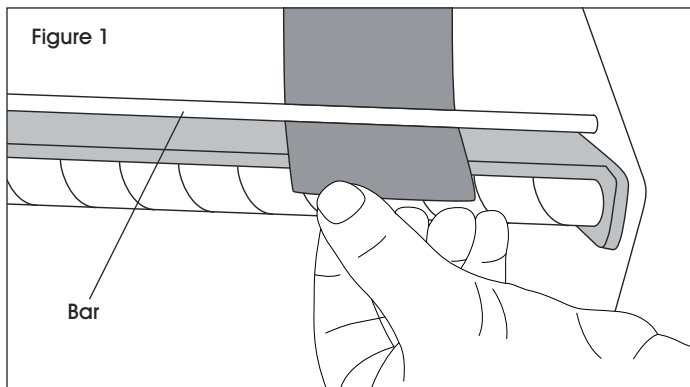

2. Insert the liner between the plastic plate and coil. (See Figure 2)

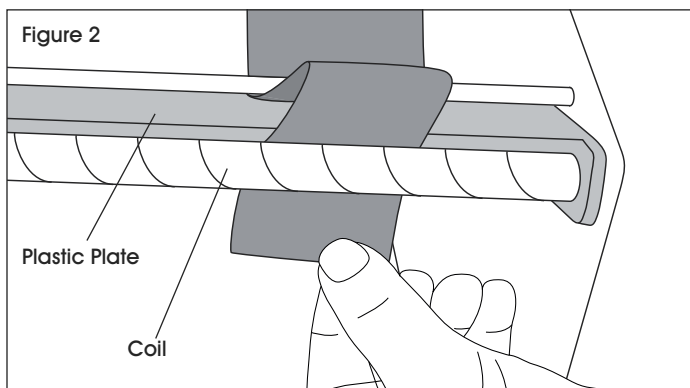

3. Pull on liner until label is released. (See Figure 3)

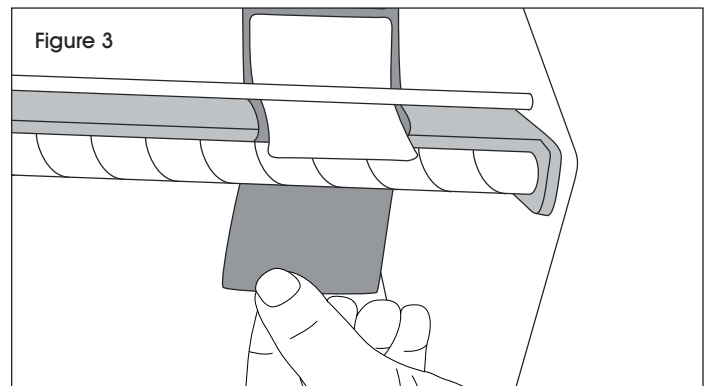

4. To use dividers, push pointed end into a slot on the plastic plate and affix rounded end into the corresponding groove on the larger plastic roller. (See Figure 4)

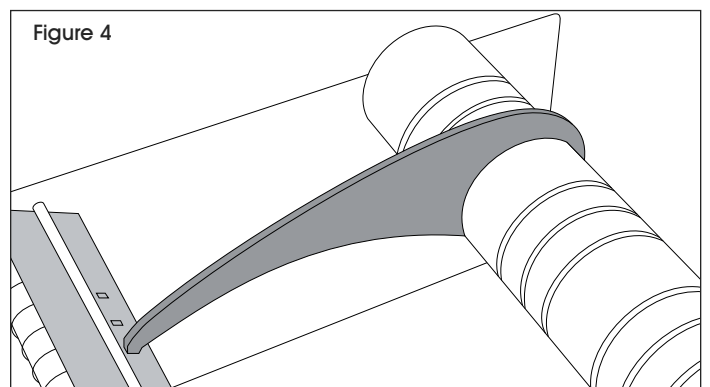

ULINE H-17, H-587
DESPACHADOR DE
ETIQUETAS DE ALTA
CALIDAD

800-295-5510
uline.mx

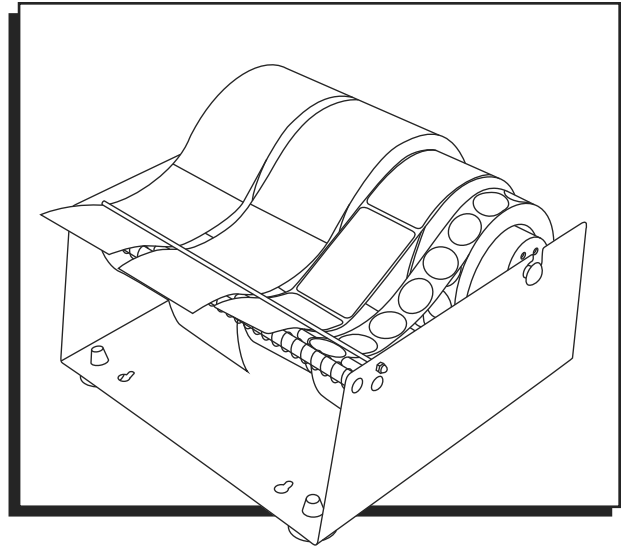

INSTRUCCIONES

1. Quite las primeras etiquetas adhesivas del rollo e inserte el respaldo por debajo de la primera barra. (Vea Diagrama 1)

 **NOTA:** Use el rodillo de plástico más grande cuando el núcleo de las etiquetas sea superior a 5 cm (2") y use el rodillo de aluminio más pequeño cuando el núcleo de las etiquetas sea inferior a 5 cm (2").

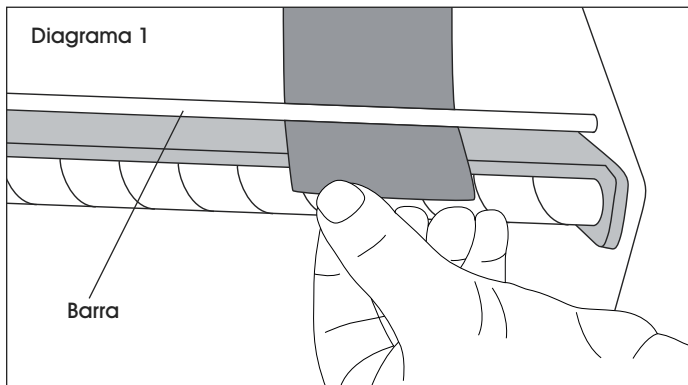

2. Inserte el respaldo entre la placa de plástico y la bobina. (Vea Diagrama 2)

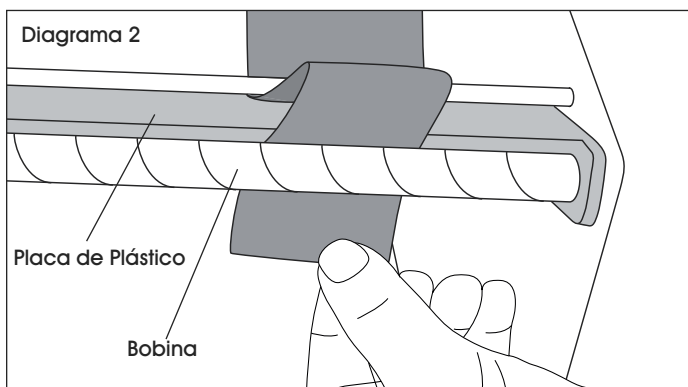

3. Tire del respaldo hasta que salga la etiqueta. (Vea Diagrama 3)

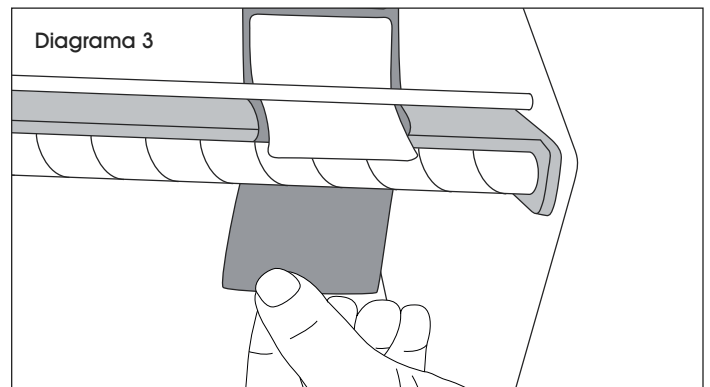

4. Para usar separadores, empuje el extremo en punta a través de la ranura de la placa de plástico e inserte el extremo redondeado en la estría correspondiente del rodillo de plástico grande. (Vea Diagrama 4)

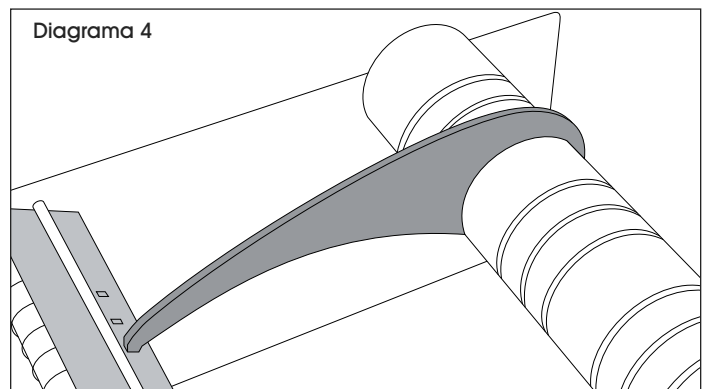

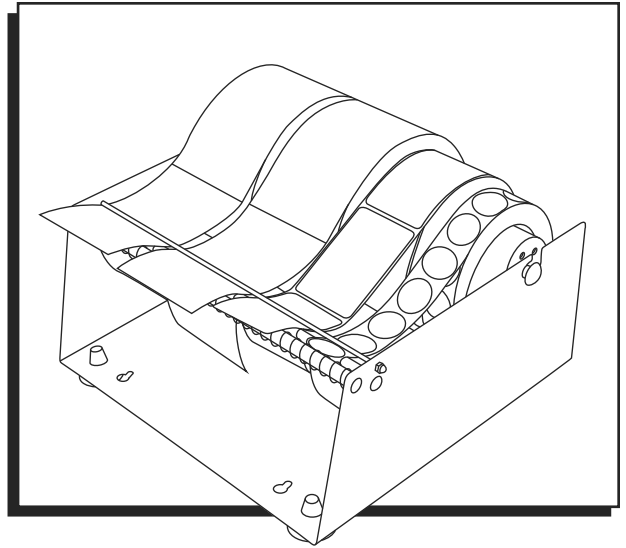

INSTRUCTIONS

1. Enlevez les premières étiquettes du début du rouleau et faites passer la pellicule sous la première barre. (Voir Figure 1)

 **REMARQUE :** Utilisez le grand rouleau en plastique lorsque la taille du mandrin du rouleau d'étiquettes est supérieure à 5 cm (2 po) et utilisez le petit rouleau d'aluminium lorsque la taille du mandrin du rouleau d'étiquettes est inférieure à 5 cm (2 po).

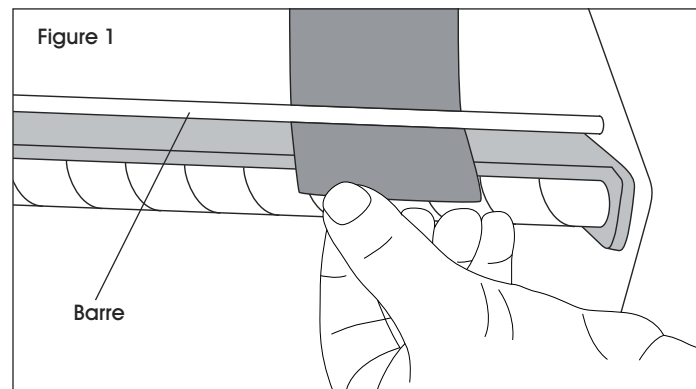

2. Insérez la pellicule entre la plaque de plastique et le rouleau. (Voir Figure 2)

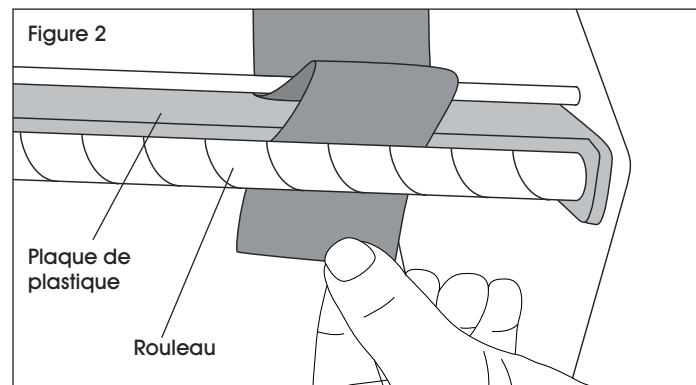

3. Tirez sur la pellicule jusqu'à ce qu'une étiquette soit libérée. (Voir Figure 3)

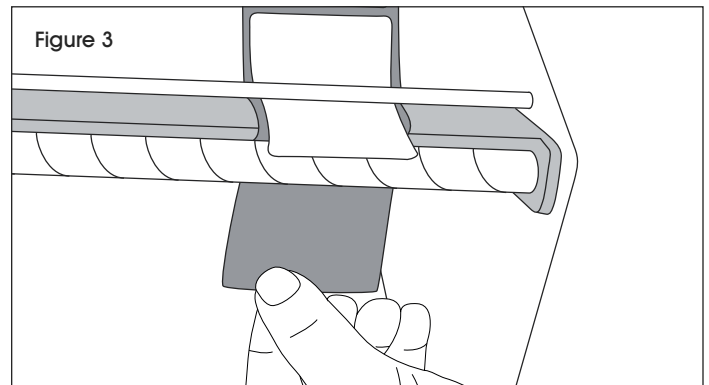

4. Pour utiliser des séparateurs, poussez l'extrémité pointue dans une fente sur la plaque de plastique et fixez l'extrémité arrondie dans la rainure correspondante sur le grand rouleau en plastique. (Voir Figure 4)

