

ULINE H-180BUMPER

BUMPER FOR HANDI-MOVER

1-800-295-5510
uline.com

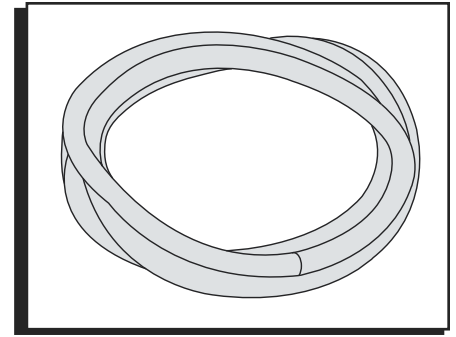

TOOL NEEDED



Heat-Resistant
Gloves

INSTALLATION

1. Place bumper into boiling water. Allow the bumper to soften for about 1-2 minutes.
2. With tongs and heat-resistant gloves, remove the bumper from the water.
3. Wipe bumper dry with heat-resistant gloves and a soft cloth. Stretch bumper onto and around the Handi-Mover platform. (See Figures 1-2)

Figure 1

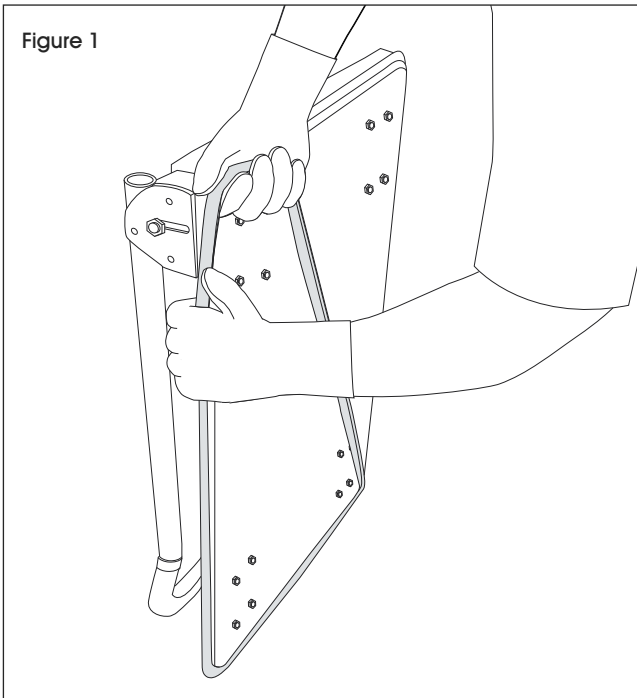
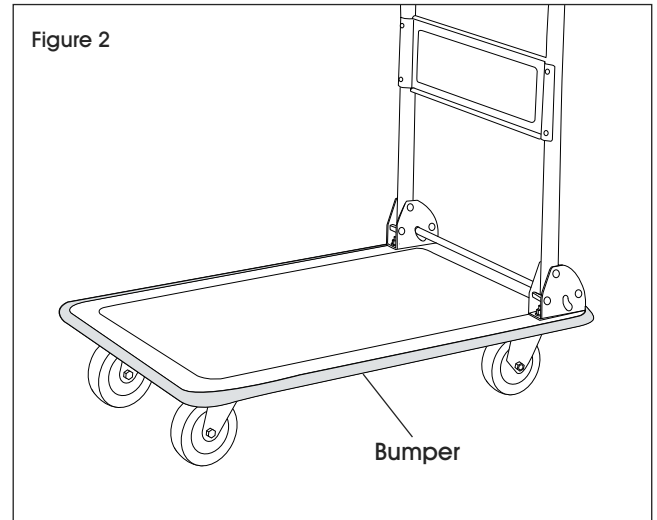
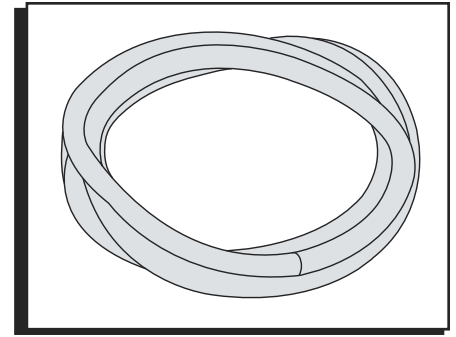

Figure 2



ULINE H-180BUMPER PARACHOQUES PARA CARRITO MANUAL

800-295-5510
uline.mx



HERRAMIENTA NECESARIA



Guantes Resistentes
al Calor

INSTALACIÓN

1. Coloque el parachoques en agua hirviendo. Permita que el parachoques se ablande durante aproximadamente 1-2 minutos.
2. Con unas pinzas y guantes resistentes al calor, retire el parachoques del agua.
3. Seque el parachoques con guantes resistentes al calor y un trapo suave. Estire el parachoques sobre y alrededor de la plataforma del Carrito Manual. (Vea Diagramas 1-2)

Diagrama 1



Diagrama 2



ULINE H-180BUMPER

PARE-CHOC POUR CHARIOT À PLATEFORME PRATIQUE

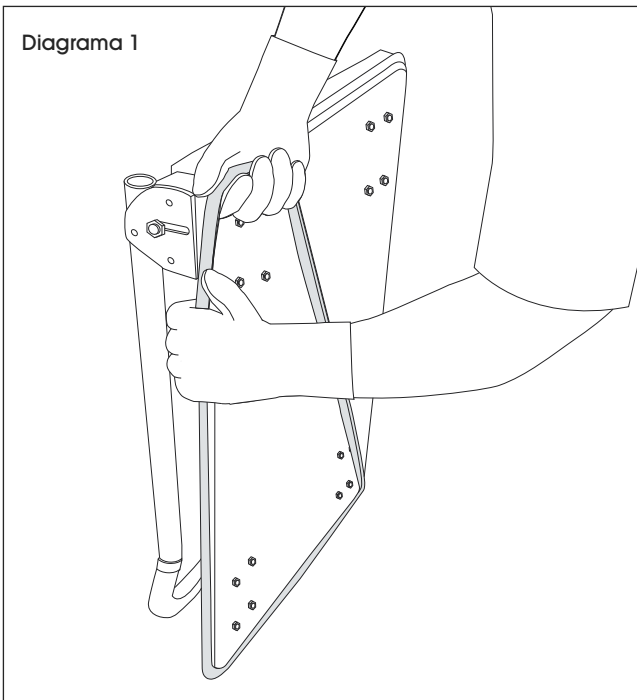
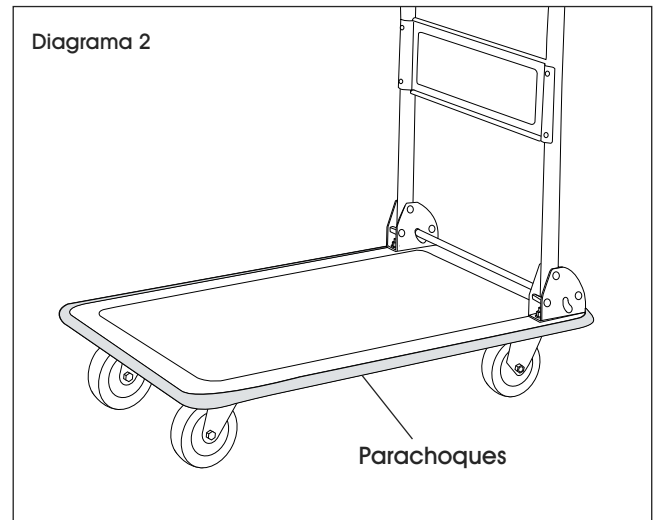
1 800 295-5510
uline.ca

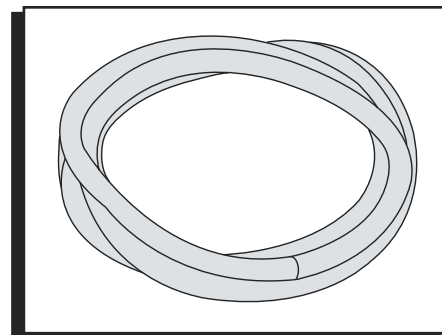

OUTIL REQUIS



Gants résistants
à la chaleur

INSTALLATION

1. Plongez le pare-chocs dans de l'eau bouillante. Laissez-le ramollir pendant environ 1 à 2 minutes.
2. À l'aide d'une pince et de gants résistants à la chaleur, retirez le pare-chocs de l'eau.
3. En portant des gants résistants à la chaleur, essuyez le pare-chocs avec un chiffon doux. Installez le pare-chocs en l'étirant autour du chariot à plateforme pratique. (Voir Figures 1 et 2)

Figure 1

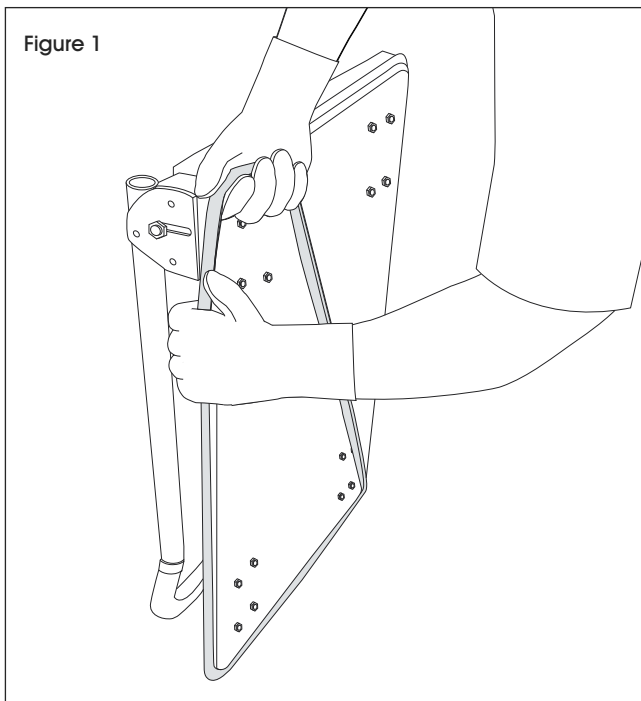

Figure 2

