

ULINE H-412, H-413, H-1921
 H-1922, H-1923, H-2267
MULTI-DECK PAPER CUTTER

1-800-295-5510
 uline.com

Para Español, vea páginas 3-4.
 Pour le français, consulter les pages 5-6.

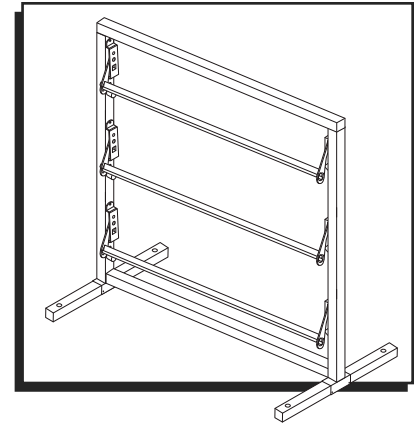

TOOL NEEDED



7/16" Wrench

PARTS INCLUDED

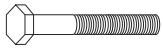

1/4-20 x 1 3/4" Hex Head
 Grade 5 Bolt x 4



1/4" Flat Washer x 4



1/4-20 Keps Hex Nut x 4



Dowel
 x 2 (2-Roll Holder)
 x 3 (3-Roll Holder)
 x 4 (4-Roll Holder)

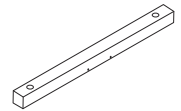

Foot x 2

ASSEMBLY

1. Fasten the two feet onto the frame of the tower as shown in the illustration below by using four bolts, nuts, washers and lockwashers.
2. Rest the dowels in the dowel sockets.

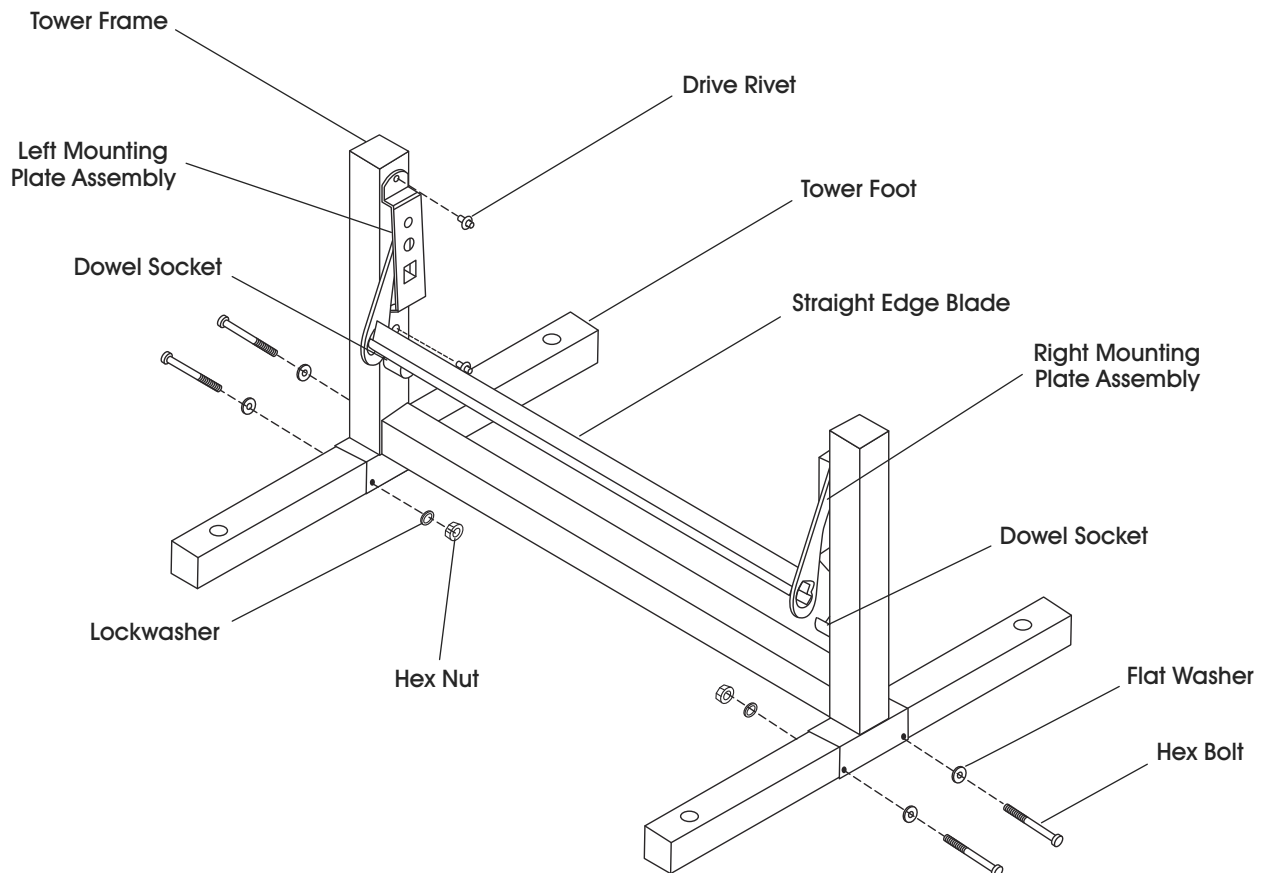

PAPER ROLL MOUNTING INSTRUCTIONS

HOW TO LOAD AND DISPENSE THE ROLL

1. Make sure both ends of the roll are plugged with cores. (See Figure 1)
2. Thread dowel through one end of the roll until it protrudes out of the other side. (See Figure 2)
3. To position roll on the paper cutter, rest the dowel in the dowel sockets with the roll unspooling downward under the straight edge blade. (See Figure 3)
4. Pull paper to the desired length and tear against the straight edge blade. (See Figure 4)

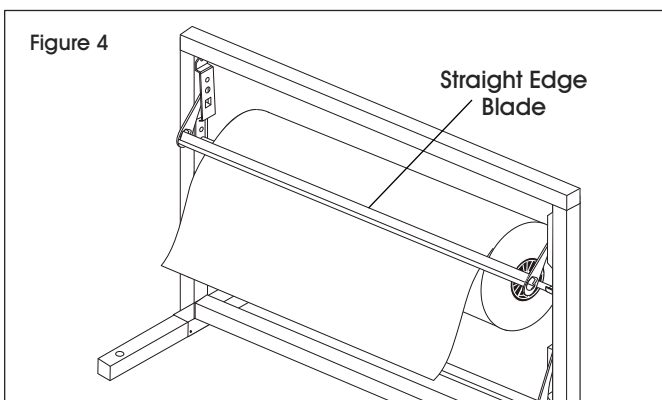
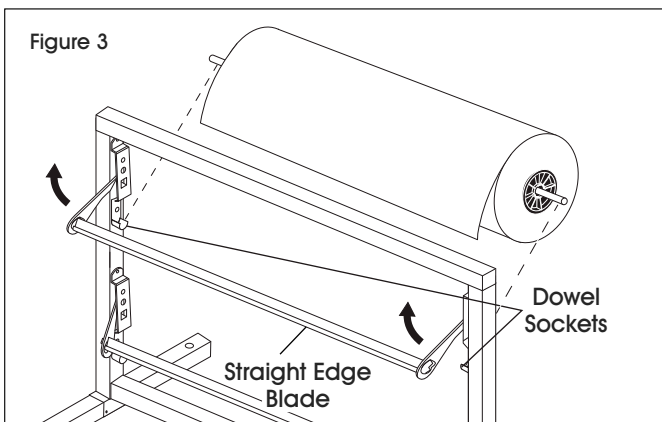
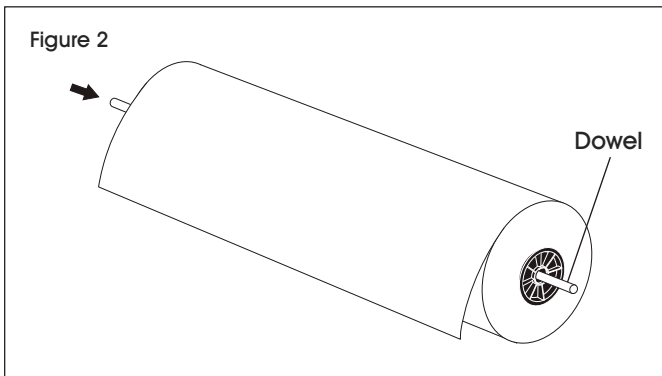
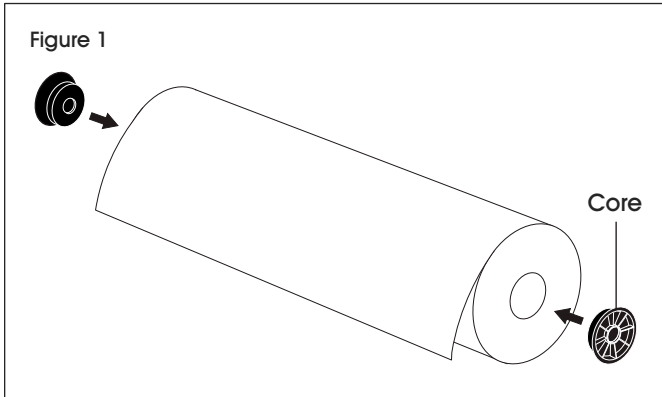

ULINE

1-800-295-5510
uline.com

ULINE H-412, H-413, H-1921
H-1922, H-1923, H-2267

CORTADORA DE PAPEL MULTIRROLLOS

800-295-5510
uline.mx

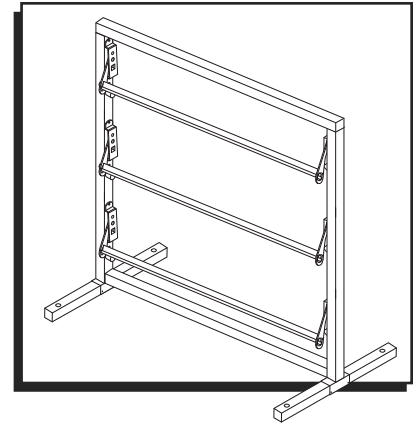

HERRAMIENTA NECESARIA



Llave de 7/16"

PARTES INCLUIDAS

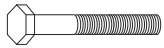

4 Pernos de Cabeza Hexagonal Grado 5 de 1/4-20 x 1 3/4"



4 Rondanas Planas de 1/4"



4 Tuercas Hexagonales Keps de 1/4-20



Cilindro
x 2 (Soporte para 2 Rollos)
x 3 (Soporte para 3 Rollos)
x 4 (Soporte para 4 Rollos)

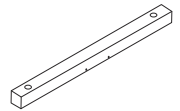

2 Patas

ENSAMBLE

1. Fije las dos patas al armazón de la torre como se muestra en la ilustración que aparece abajo usando cuatro pernos, tuercas, rondanas y rondanas de seguridad.
2. Apoye los cilindros sobre las ranuras para cilindro.

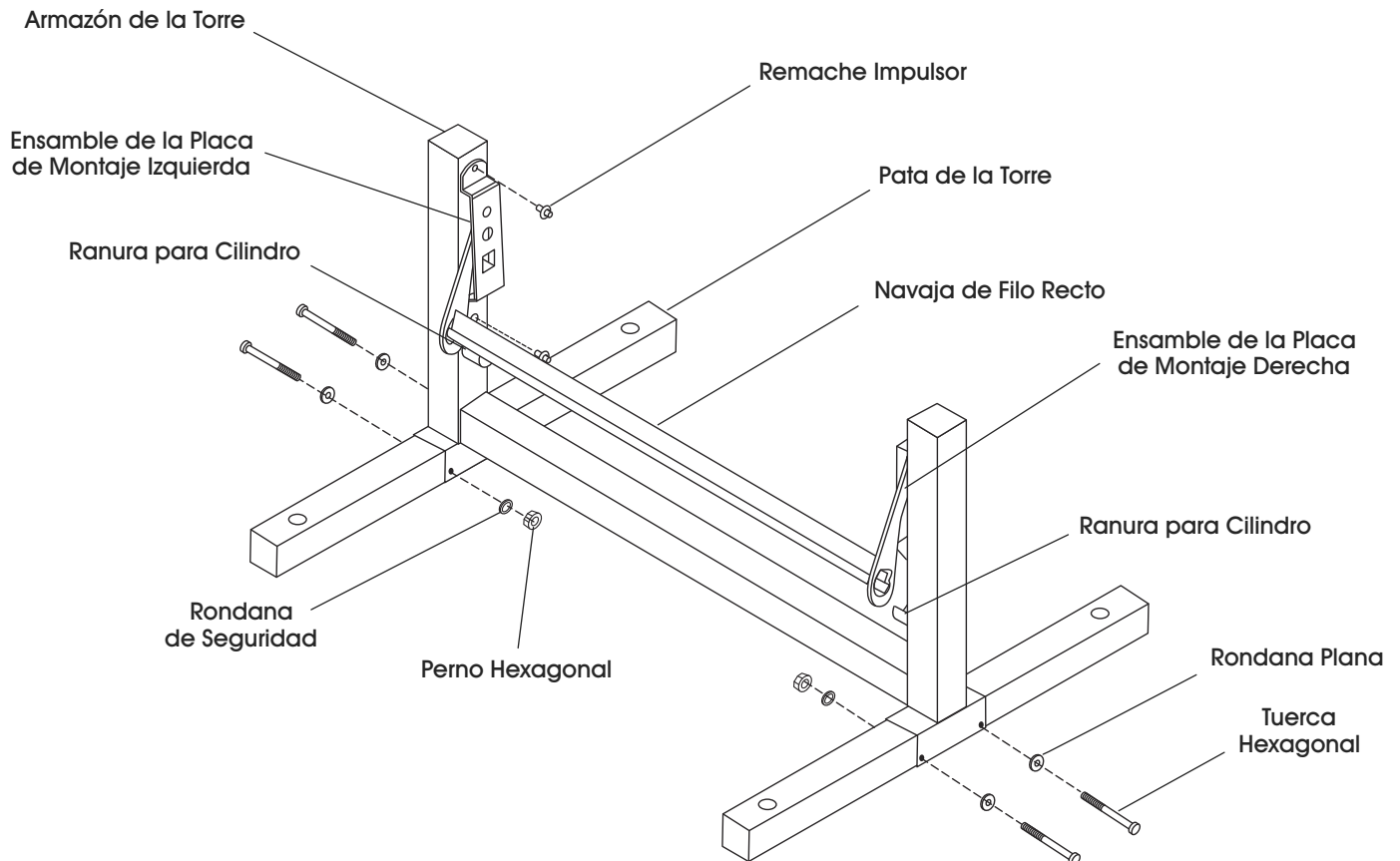

INSTRUCCIONES PARA INSTALAR EL ROLLO DE PAPEL

CÓMO CARGAR Y DESPACHAR EL ROLLO

1. Asegúrese de que ambos extremos del rollo estén conectados con núcleos. (Vea Diagrama 1)

2. Inserte el cilindro a través de uno de los extremos del rollo hasta que sobresalga del otro lado. (Vea Diagrama 2)

3. Para colocar el rollo en la cortadora de papel, coloque el cilindro en las ranuras para cilindros con el rollo desenrollándose hacia abajo por debajo de la navaja de filo recto. (Vea Diagrama 3)

4. Jale el papel al largo deseado y jale contra el filo recto de la navaja. (Vea Diagrama 4)

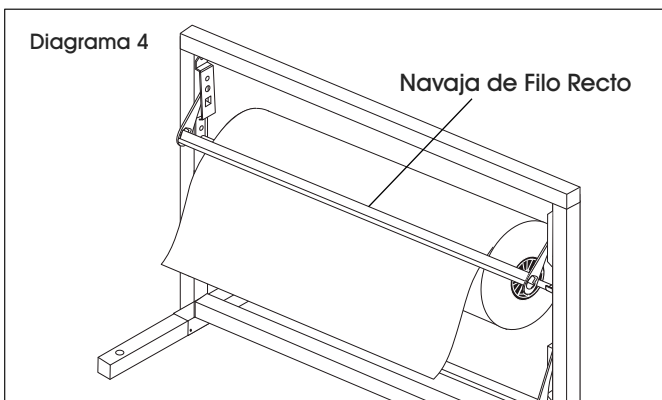
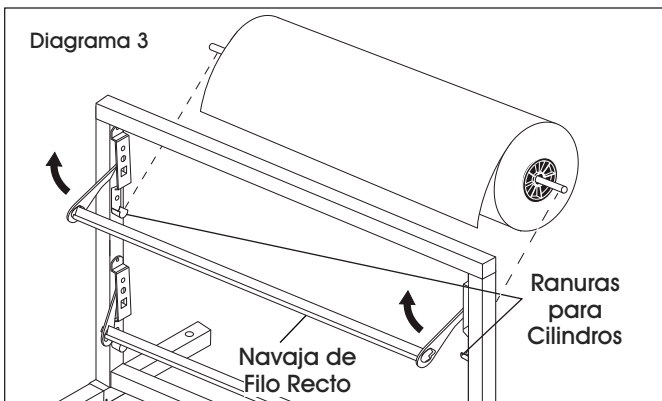
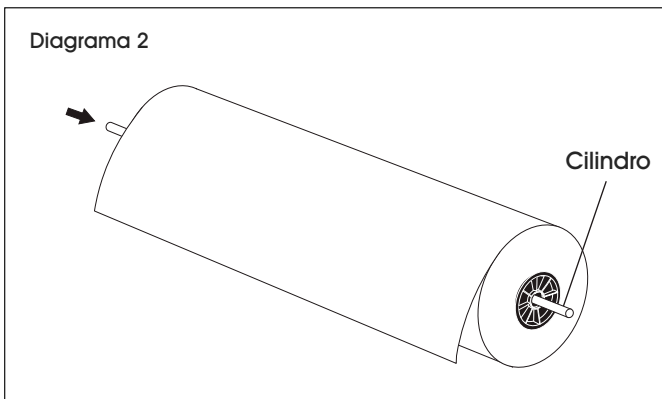
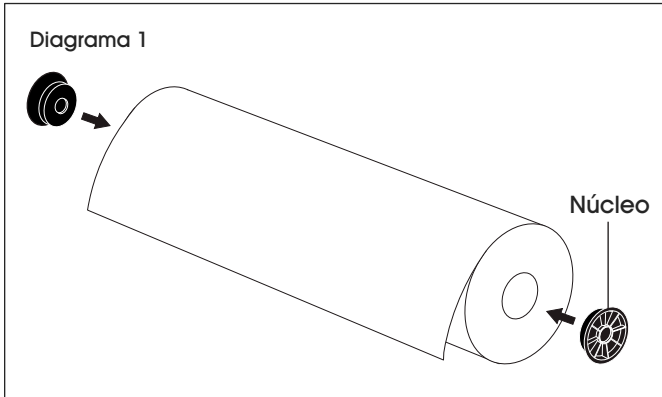

ULINE

800-295-5510
uline.mx

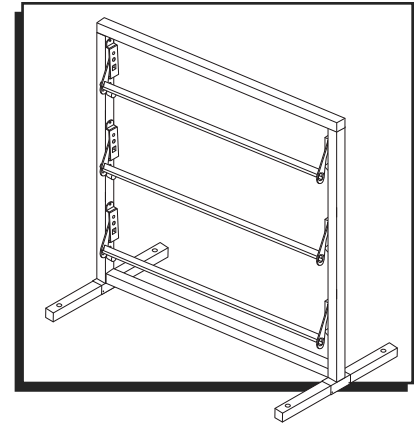

OUTIL REQUIS



Clé de 7/16 po

PIÈCES INCLUSES

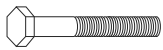

Boulon à tête hexagonale
 1/4-20 x 1 3/4 po,
 catégorie 5 x 4



Rondelle plate
 de 1/4 po x 4



Écrou hexagonal
 à rondelle dentée
 1/4-20 x 4



Goujon
 x 2 (support pour 2 rouleaux)
 x 3 (support pour 3 rouleaux)
 x 4 (support pour 4 rouleaux)

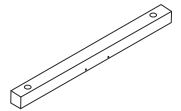

Pied x 2

MONTAGE

1. Fixez les deux pieds au cadre de la tour, comme illustré ci-dessous, à l'aide de quatre boulons, écrous, rondelles et rondelles de blocage.
2. Déposez les goujons dans les supports de goujon.

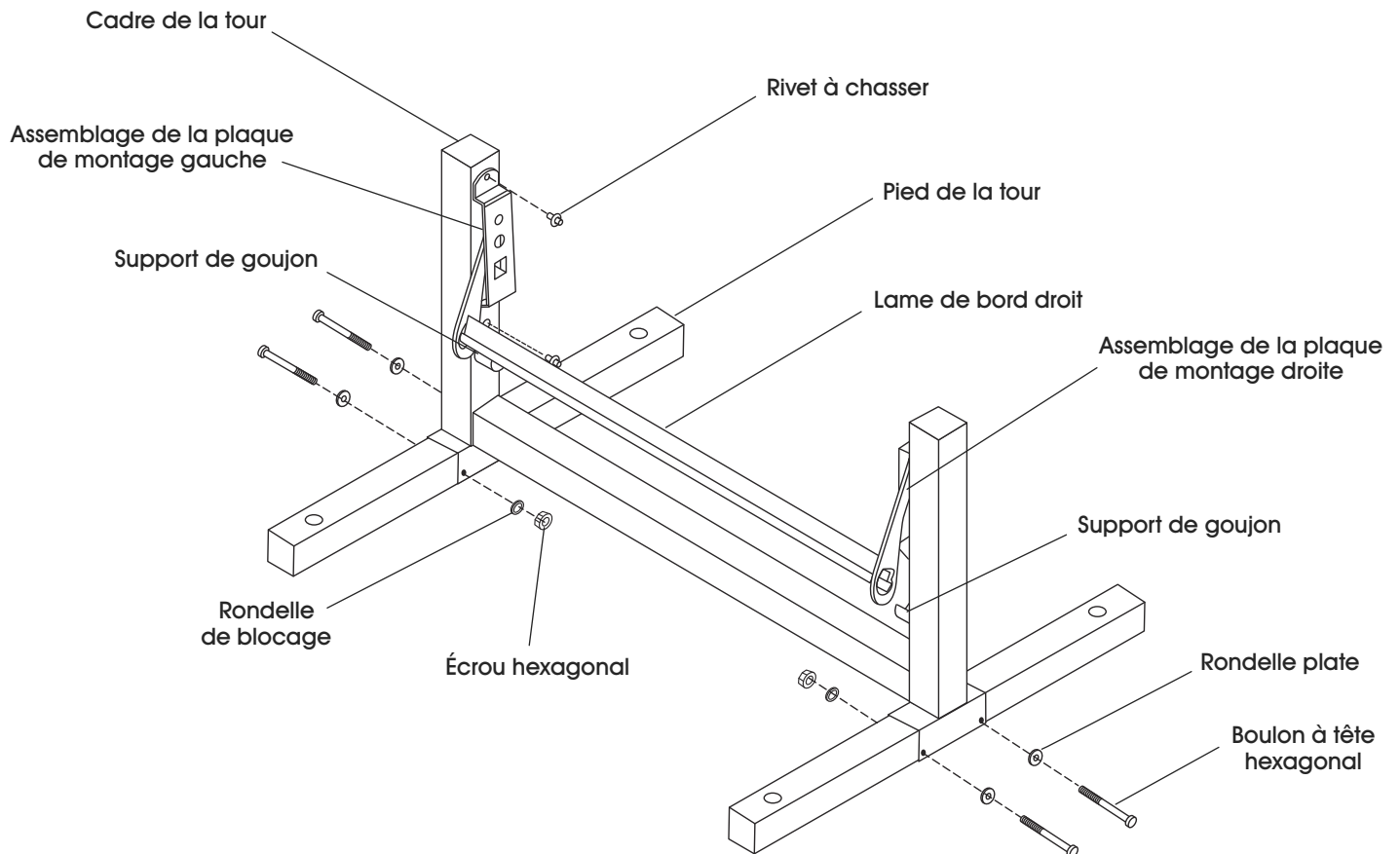

INSTRUCTIONS D'INSTALLATION DU ROULEAU DE PAPIER

COMMENT CHARGER ET DISTRIBUER LE ROULEAU

1. Assurez-vous que les mandrins sont insérés aux deux extrémités du rouleau. (Voir Figure 1)
2. Introduisez le goujon dans une extrémité du rouleau jusqu'à ce qu'il ressorte sur l'autre extrémité. (Voir Figure 2)
3. Pour positionner le rouleau sur le coupe-papier, déposez le goujon sur les supports de goujon en vous assurant que le rouleau se déroulera vers le bas, en dessous de la lame de bord droit. (Voir Figure 3)
4. Tirez le papier jusqu'à la longueur désirée et coupez-le à l'aide de la lame de bord droit. (Voir Figure 4)

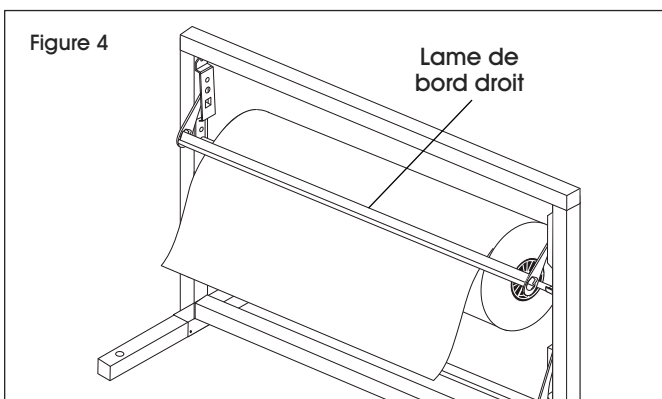
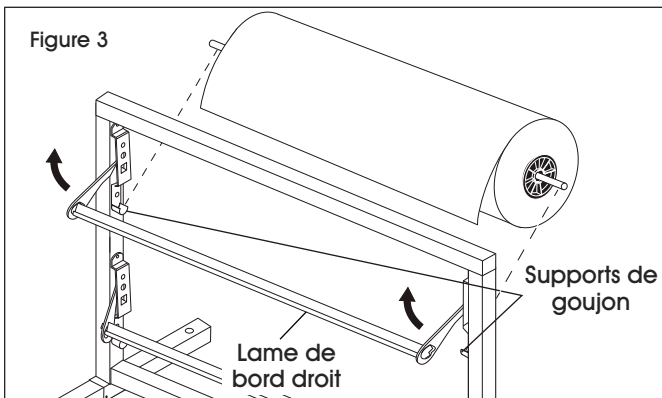
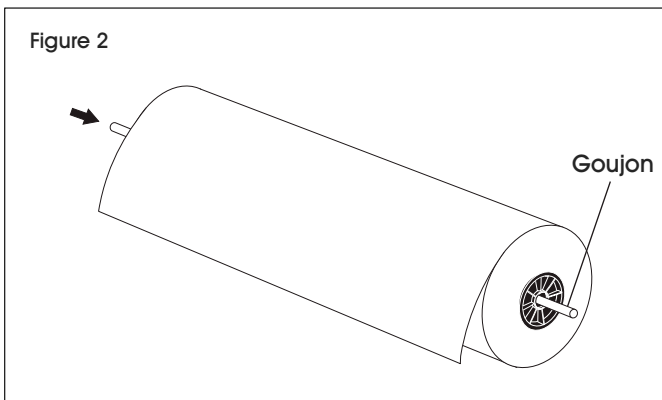
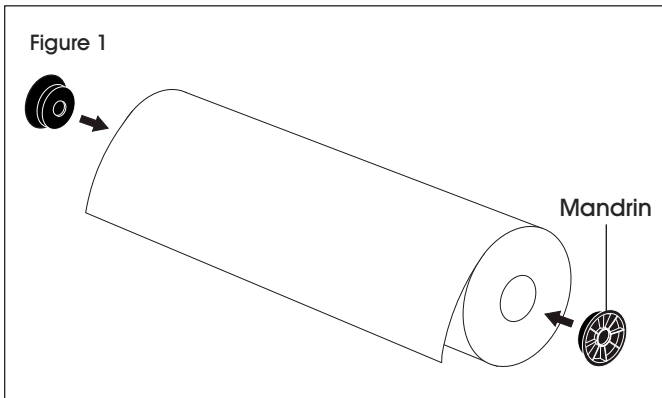

ULINE

1-800-295-5510
uline.ca