

**ULINE** H-1978, H-8532RT  
H-8577  
**Z-RACK**

1-800-295-5510  
uline.com

Para Español, vea páginas 3-4.  
Pour le français, consulter les pages 5-6.

**TOOLS INCLUDED**



1/4" Allen Wrench



Thin Open End Wrench

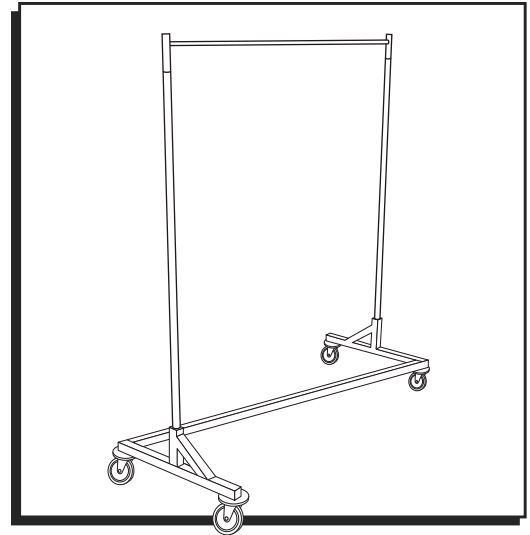

**PARTS**



Horizontal Hang Bar x 1



Vertical Bar x 2

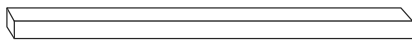

Frame Cross Bar x 1



Swivel Caster x 2



Swivel Caster with Brake x 2



Caster Bumper x 4

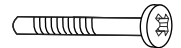

Bolt x 4

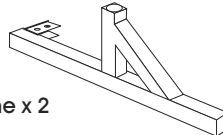

Frame x 2



Nut x 4



Lock Washer x 4



Washer x 4

**ASSEMBLY**

1. Remove the included washers and bolts from the frames, using the included 1/4" Allen wrench. (See Figure 1)
2. Slide the frame and the frame cross bar together, aligning the bolt holes. (See Figure 2)
3. Insert bolts into aligned bolt holes, placing the washers between the frame and bolt. Tighten using included 1/4" Allen wrench. (See Figure 3)

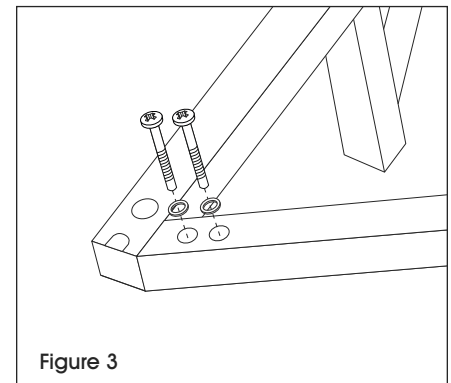
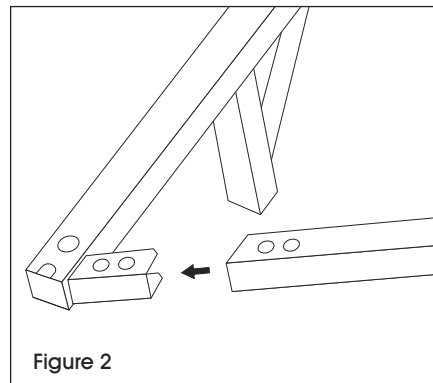
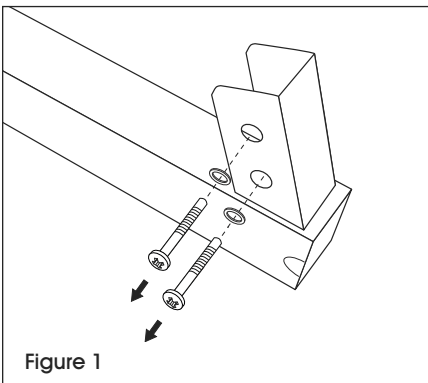

## ASSEMBLY INSTRUCTIONS CONTINUED

4. Remove nut and lock washer from caster.
5. Place caster bumpers on casters with concave side toward caster.
6. Align and insert casters with rubber bumpers. Tighten nut on opposite side using included wrench. (See Figure 4)

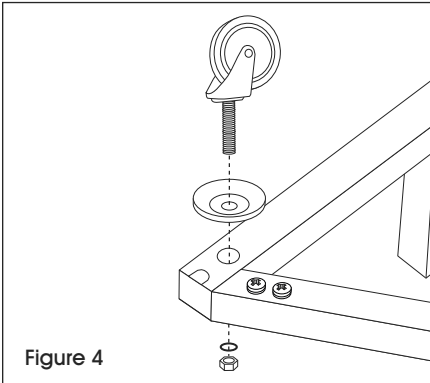

7. Insert the vertical support bars into the frame. (See Figure 5)

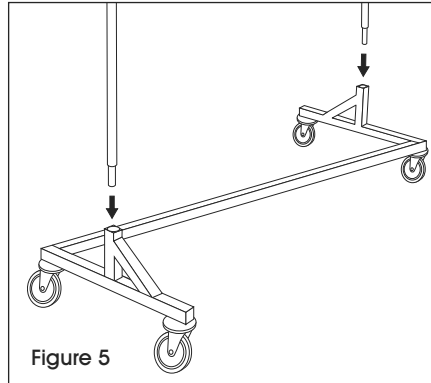

8. Slide horizontal hang bar on to top of the vertical support bars and lock into place. (See Figure 6)

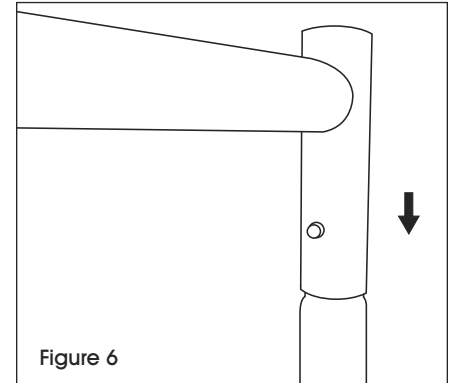

**ULINE**

1-800-295-5510  
uline.com

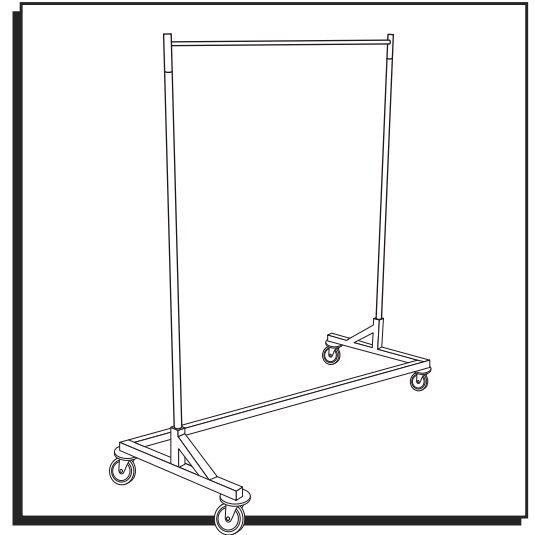

**HERRAMIENTAS INCLUIDAS**



Llave Allen de 1/4"



Llave Delgada con Extremo Abierto

**PARTES**

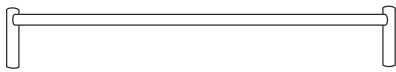

1 Barra Horizontal para Colgar



2 Ruedas Giratorias



2 Ruedas Giratorias con Freno



4 Topes de Rueda

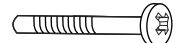

4 Pernos

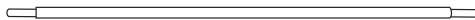

2 Barras Verticales

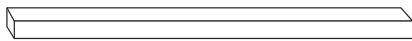

1 Barra Transversal para Armazón

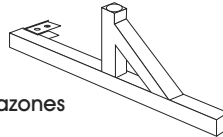

2 Armazones



4 Tuercas



4 Rondanas de Seguridad



4 Rondanas

**ENSAMBLE**

1. Retire las rondanas y los pernos incluidos en los armazones utilizando la llave Allen de 1/4" incluida. (Vea Diagrama 1)
2. Deslice juntos el armazón y la barra transversal del armazón, alineando los orificios de los pernos. (Vea Diagrama 2)
3. Inserte los pernos en los orificios alineados correspondientes, colocando las rondanas entre el armazón y el perno. Apriete con la llave Allen de 1/4" incluida. (Vea Diagrama 3)



Diagrama 1



Diagrama 2

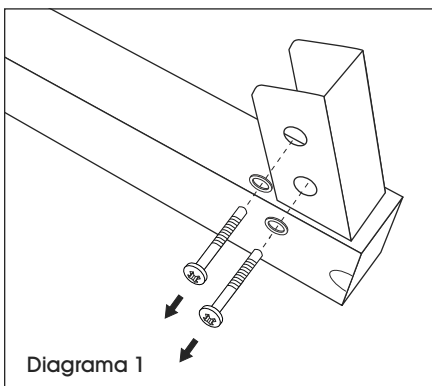

Diagrama 3

## CONTINUACIÓN DE INSTRUCCIONES DE ENSAMBLE

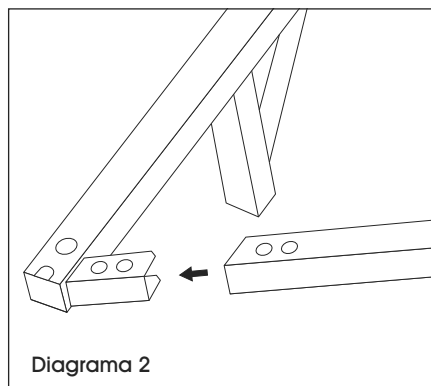
4. Quite la tuerca y la rondana de seguridad de la rueda.
5. Coloque los topes sobre las ruedas con el lado cóncavo apuntando hacia ellas.
6. Alinee e inserte las ruedas con topes de goma. Apriete la tuerca en el lado opuesto con la llave incluida. (Vea Diagrama 4)

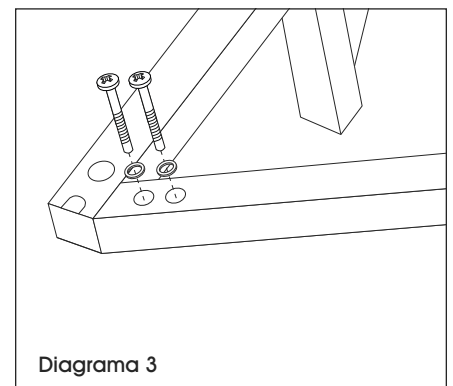
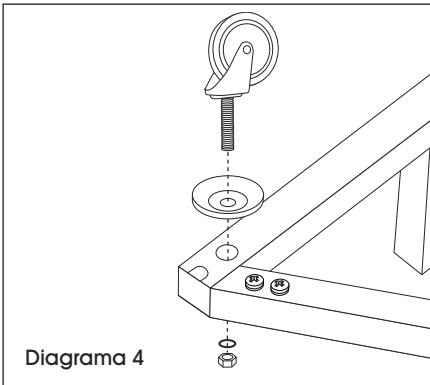

7. Inserte las barras de soporte verticales en el armazón. (Vea Diagrama 5)

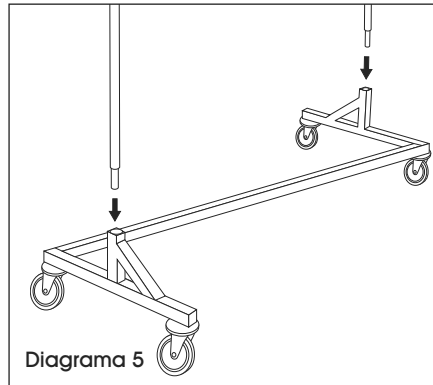

8. Deslice la barra horizontal para colgar en la parte superior de las barras verticales de soporte y fíjela en su lugar. (Vea Diagrama 6)

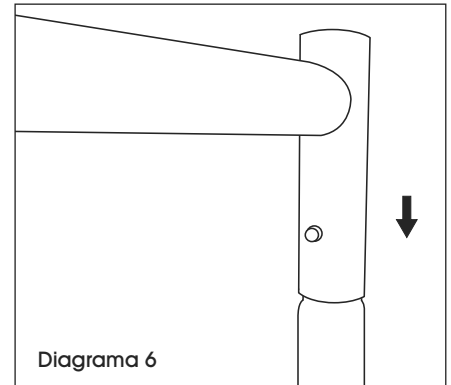

**ULINE**

800-295-5510  
uline.mx

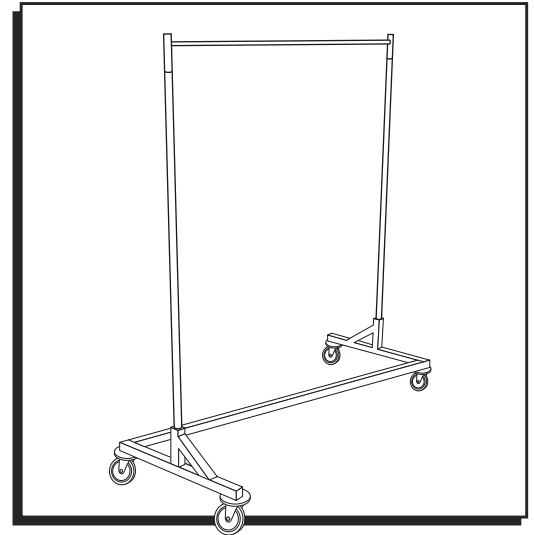

**OUTILS INCLUS**



Clé Allen de 1/4 po



Clé plate

**PIÈCES**

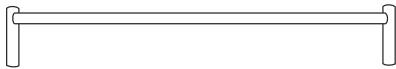

Barre de suspension horizontale x 1



Roulette pivotante x 2



Roulette pivotante avec frein x 2



Butée de roulette x 4

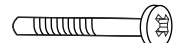

Boulon x 4

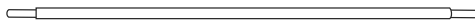

Barre verticale x 2

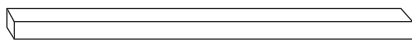

Traverse de socles x 1

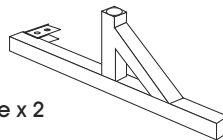

Socle x 2



Écrou x 4



Rondelle de blocage x 4



Rondelle x 4

**ASSEMBLAGE**

1. Retirez les rondelles et boulons des socles à l'aide de la clé Allen de 1/4 po incluse. (Voir Figure 1)

2. Insérez les socles dans la traverse de socles en prenant soin d'aligner les trous de boulon. (Voir Figure 2)

3. Insérez des boulons dans les trous de boulon alignés en prenant soin d'installer une rondelle entre le socle et le boulon. Serrez-les à l'aide de la clé Allen de 1/4 po incluse. (Voir Figure 3)

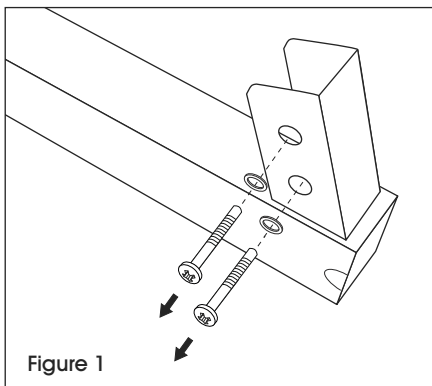

Figure 1

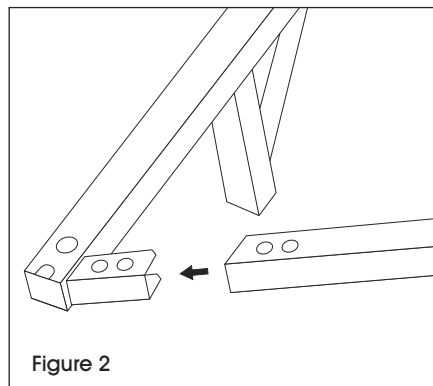

Figure 2

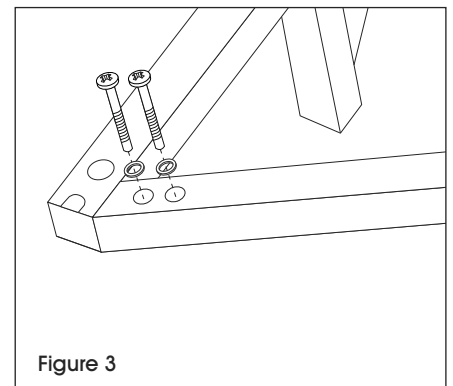
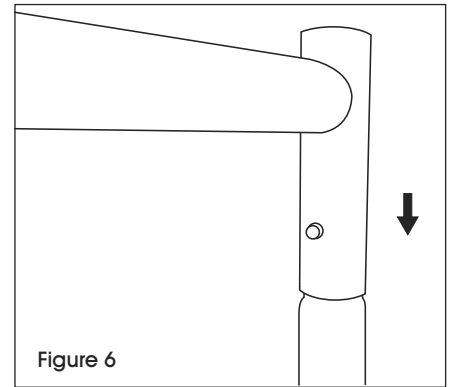
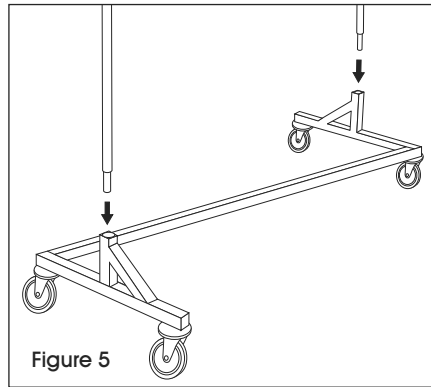
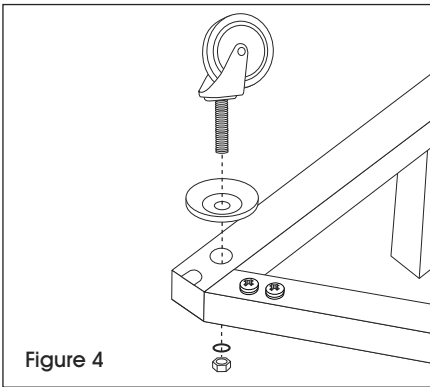

Figure 3

## ASSEMBLAGE SUITE

4. Enlevez l'écrou et la rondelle de blocage de la roulette.
5. Placez les butées des roulettes sur les roulettes, côté concave orienté vers la roulette.
6. Alignez et insérez les ensembles roulette et butée de roulette. Serrez l'écrou du côté opposé à l'aide de la clé plate incluse. (Voir Figure 4)
7. Insérez les barres verticales dans les socles. (Voir Figure 5)
8. Glissez la barre de suspension horizontale sur les barres verticales et verrouillez-la en position. (Voir Figure 6)



**ULINE**

1-800-295-5510  
uline.ca