

# ULINE H-2043

## ANTI-STATIC WORKBENCH

1-800-295-5510  
uline.com

Para Español, vea páginas 7-12.  
Pour le français, consulter les pages 13-18.

### TOOLS NEEDED



Two Person Assembly  
Recommended

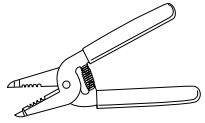

Wire Stripper

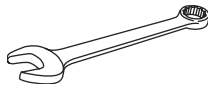

7/16" Wrench

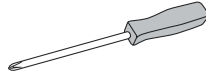

Phillips  
Screwdriver



3/16" Allen Wrench  
1/8" Allen Wrench  
(Included)

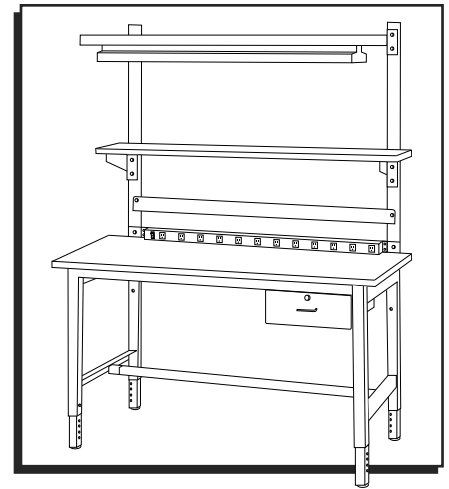

### PARTS

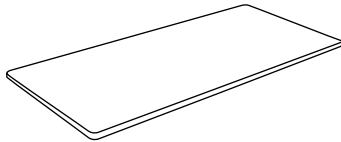

Bench Top x 1

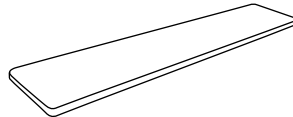

Shelf x 1

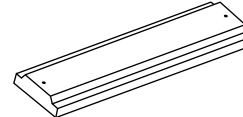

Light Fixture x 1

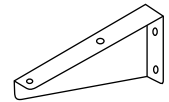

Shelf Bracket x 2

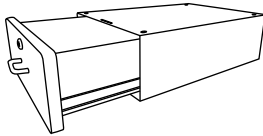

Drawer Assembly x 1

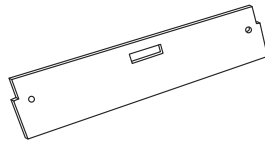

Drawer Front  
Mounting Plate x 1

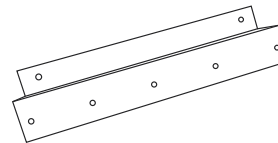

Drawer Back  
Mounting Plate x 1

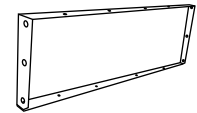

Back Rail x 1

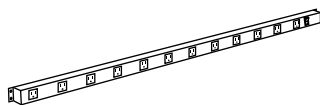

48" Electrical Strip x 1

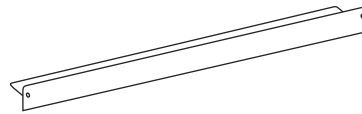

Metal Bin Holder x 1

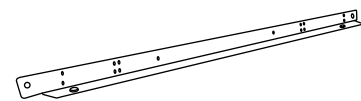

Electrical Strip Mounting Rail x 1

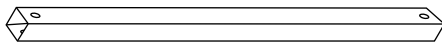

Footrest Crossbeam x 1

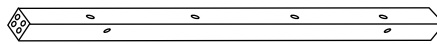

Front Rail x 1

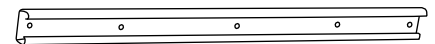

Shelf Support Beam x 1



Vertical Upright x 2



Light Fixture Support Beam x 1

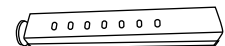

Leg Extender x 4



Light Fixture Support Frame x 1

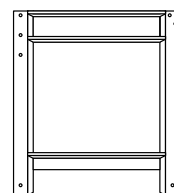

Leg Assembly x 2

# HARDWARE



1/4 x 2 3/4" Hex Head Bolt x 4



5/16 x 2 1/2" Hex Head Bolt x 1



1/4 x 3/4" Hex Head Bolt x 6

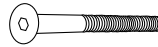

3/16 x 2 3/4" Flat Allen Head Bolt x 2

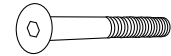

3/16 x 2 1/4" Flat Allen Head Bolt x 2



3/8 x 1" Allen Head Bolt x 12

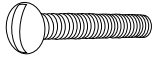

3/16 x 2 3/8" Round Head Bolt x 4



3/16 x 3/8" Round Head Bolt x 4

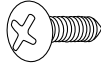

3/4" Wood Screw x 25



3/16" Cap Nut x 4



3/16" Locknut x 4



1/4" Locknut x 8

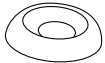

1/4" Finish Washer x 4



5/16" Flat Washer x 3  
(2 thin, 1 thick)  
1/4" Flat Washer x 22



5/16" Serrated Washer x 1



3/16" Lock Washer x 4



3/16" Nut x 4



5/16" Nut x 3  
(2 thin, 1 thick)



Ring Terminal x 3



Cable Tie x 4

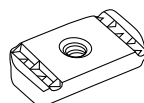

1/4" Strut Nut x 4

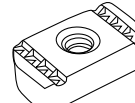

3/8" Strut Nut x 12



Self-Adhesive Pad x 4

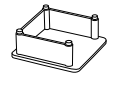

End Cap x 4

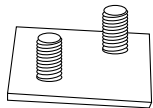

2 x 2" Stud Plate x 2

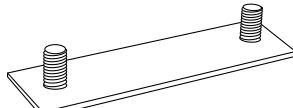

1 x 3/8" Stud Plate x 2

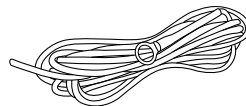

Bundle of Wire with Pre-wired Ring Terminal x 1

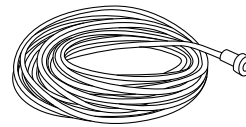

5/16" Pre-wired Jack x 2

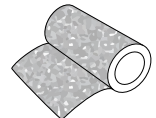

Footrest Guard Tape x 1

# ASSEMBLY

## FRAME

- Loosely attach front and back rail to leg assemblies using stud plates and 1/4" locknuts. Ensure the rail side with four holes is facing the top of the workbench. (See Figure 1)



**IMPORTANT!** Ensure front and back rails are flush with the top of leg assemblies and pushed inward approximately 1/8" to allow bench top to be mounted properly.

- Secure lowest holes in back rail to leg assemblies with 1/4 x 3/4" hex head bolts and 1/4" flat washers.
- Tighten all nuts and bolts. (See Figure 1)

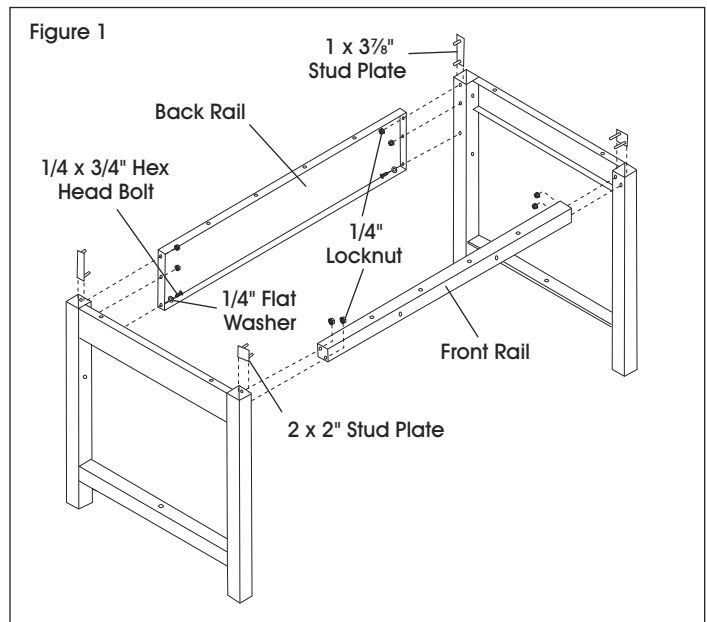

# ASSEMBLY CONTINUED

- Place bench top with the bottom facing up on a flat, non-marring surface. Place assembled frame upside down on top of the bench top.

 **NOTE:** Back rail should be flush with edge of top, and nearest the pre-drilled hole in bench top.

- Align pilot holes in bench top with holes in assembled frame. Secure with 3/4" wood screws. (See Figure 2)

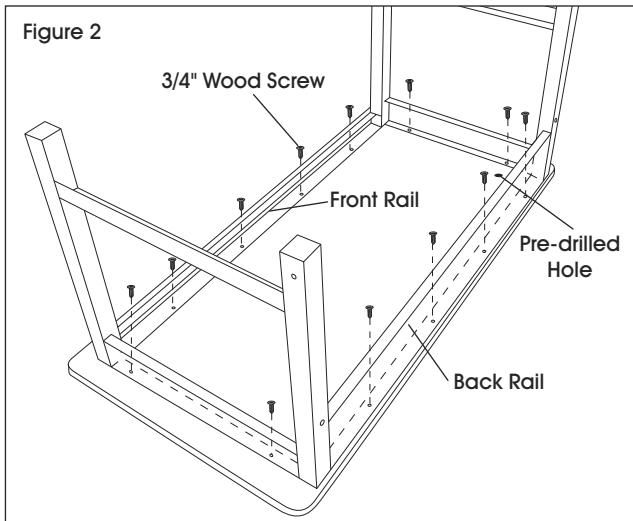

- Insert leg extenders into each leg, select desired height and insert one 3/16 x 2 3/8" round head bolt and 1/4" flat washer per leg. (See Figure 3)
- Secure round head bolt with 1/4" flat washer, 3/16 lock washer, and 3/16 cap nut on opposite side. (See Figure 3)

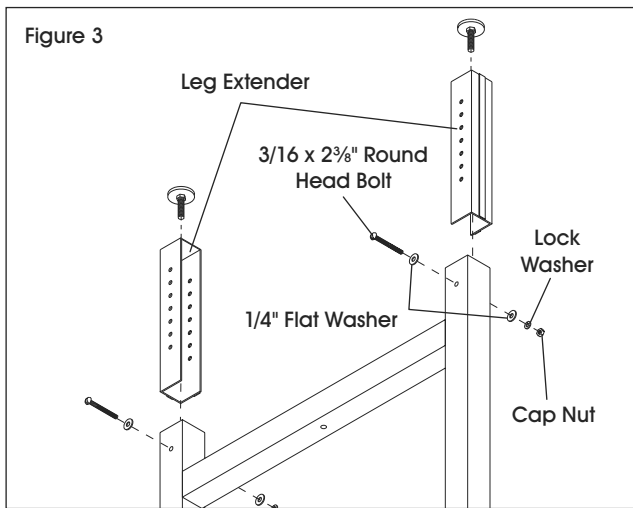

## WIRING BENCH TOP

- Install the following hardware into the pre-drilled hole on the bench top in the order listed below. (See Figure 4)

**Above bench top:** 5/16" serrated washer (A), plain ring terminal (B), 5/16 x 2 1/2" hex head bolt (C)

**Below bench top:** thin 5/16" flat washer (D), pre-wired ring terminal (E), thin 5/16" flat washer (F), yellow ring terminal (G), thick 5/16" flat washer (H), thick 5/16" nut (I)

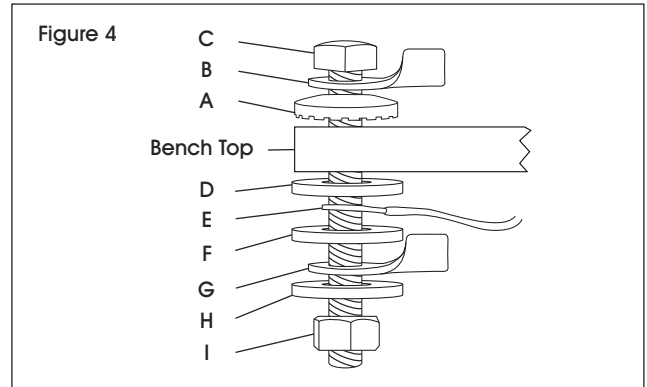

- Tighten 5/16" nut.
- Insert pre-wired jacks into holes in front rail. Mount using thin 5/16" nuts. (See Figure 5)
- Run wires from 5/16" pre-wired jacks to yellow ring terminal along underside of bench top. Use self-adhesive pads and cable ties to secure. (See Figure 5)

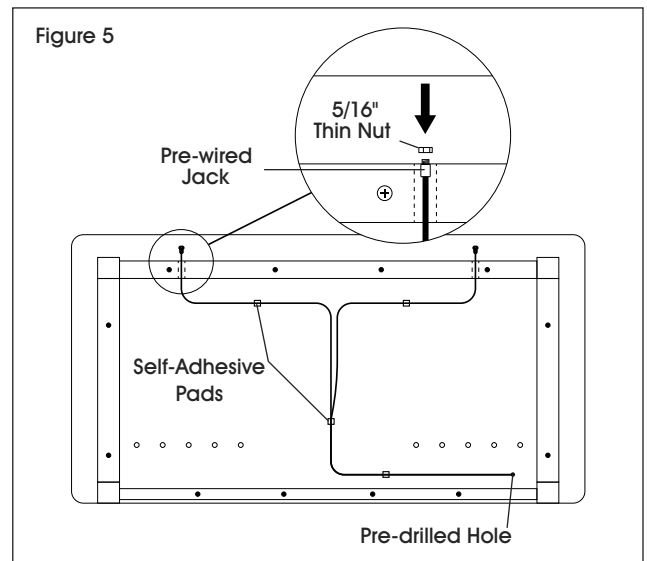

## ASSEMBLY CONTINUED

- Cut wire to appropriate length, leaving approximately 1-2" slack. Strip jack wires 1/4" and connect to the ring terminal by crimping wires in terminal.
- Strip end of wire from pre-wired ring terminal and insert into blue ring terminal. Crimp the blue ring terminal.



**IMPORTANT!** When assembly is complete, install the blue ring terminal to the center of a grounded outlet by attaching to center screw.



**NOTE:** The workbench should remain upside down after the bench top has been wired.

### DRAWER

- Pull drawer out as far as possible from housing. Slide black levers on drawer's side rails and pull the drawer completely out from housing.
- Secure front and back mounting plates to drawer housing using 1/4 x 3/4" hex head bolts and 1/4" flat washers. Tighten bolts on back mounting plate and leave bolts on front mounting plate loose. (See Figure 6)



**NOTE:** The drawer front mounting plate should overlap the front rail by 1".

- Secure back mounting plate to bench top using five 3/4" wood screws through pilot holes in bench top. Tighten previously installed hex head bolts in front mounting plate. Slide drawer into housing. (See Figure 6)

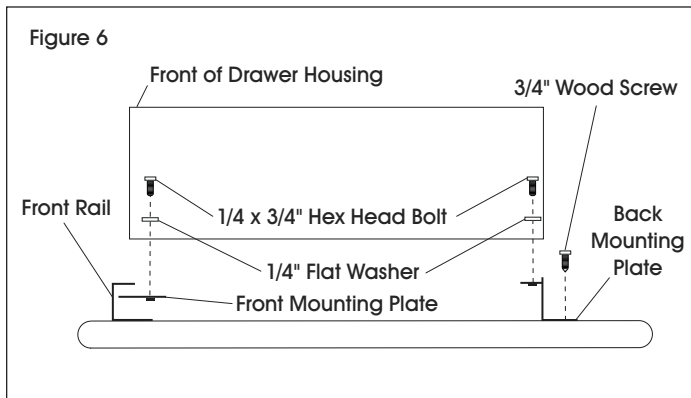

### FOOTREST

- Flip workbench right side up.
- Peel wax backing off adhesive side of footrest guard tape. Center footrest guard tape along the length of footrest. Firmly press tape to footrest. (See Figure 7)

- Attach footrest to leg assemblies using 3/16 x 2 1/4" flat Allen head bolts, 1/4" finish washers, 1/4" flat washers and 3/16" locknuts. (See Figure 7)

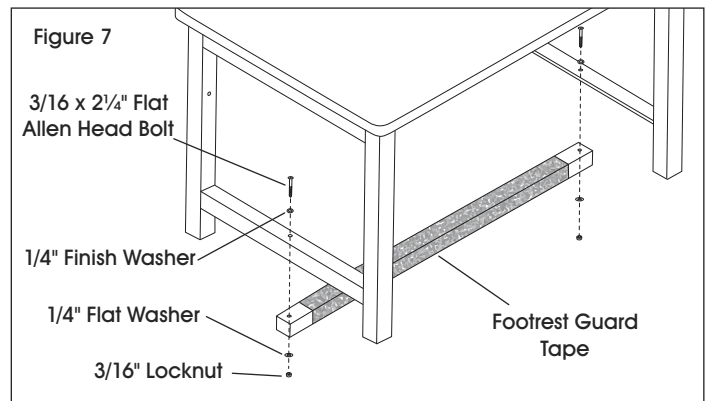

### VERTICAL UPRIGHTS

- Place two 1/4" flat washers onto two 1/4 x 2 3/4" hex head bolts. Insert bolts through rear leg at desired location. (See Figure 8)
- Thread one 1/4" strut nut onto previously installed 1/4 x 2 3/4" hex head bolt. Turn approximately two threads. (See Figure 8)
- Hold vertical uprights against the back of the rear legs. Insert strut nuts into uprights, and turn clockwise to secure nut inside of upright. Tighten hex head bolts. (See Figure 8)



**NOTE:** 12" of the upright must be located below the bench top for stability and safety.

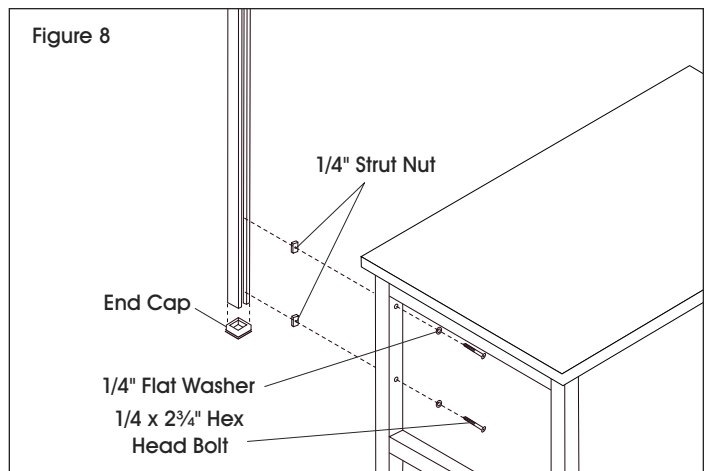

- Repeat for remaining upright.

# ASSEMBLY CONTINUED

## LIGHT FIXTURE

1. With second person, attach light fixture support frame to vertical uprights using 3/8 x 1" Allen head bolts and 3/8" strut nuts. (See Figure 9)

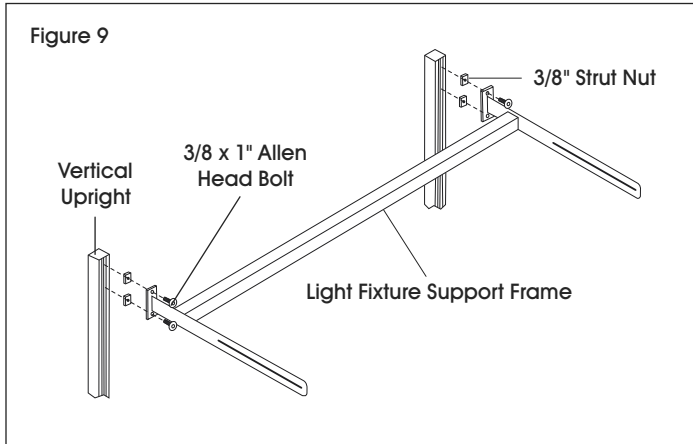

2. Attach light fixture to light fixture support beam with 3/16 x 2 3/4" Allen head bolts, 1/4" finish washers, 1/4" flat washers and 3/16" locknuts. (See Figure 10)

 **NOTE:** Remove knockouts from light fixture before attaching to light fixture support beam.

3. Mount the light fixture support beam to light support frame using large and small plastic washers and knobs. (See Figure 10)

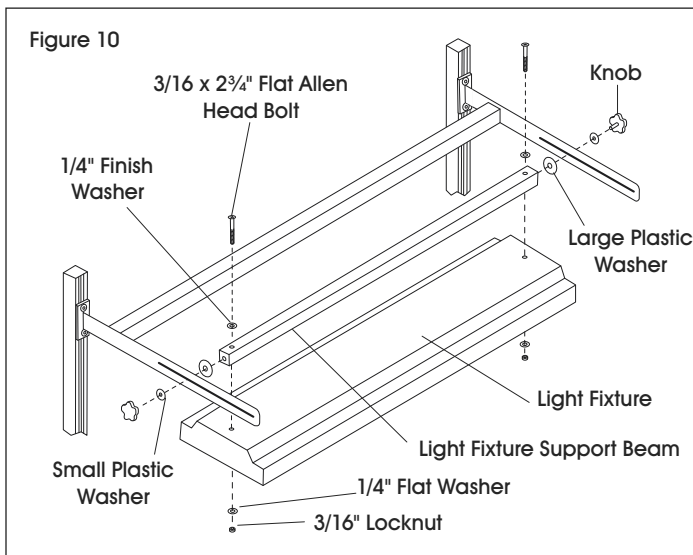

## SHELF

1. Choose desired height on vertical uprights and mount shelf brackets using 3/8 x 1" Allen head bolts and 3/8" strut nuts. (See Figure 11)

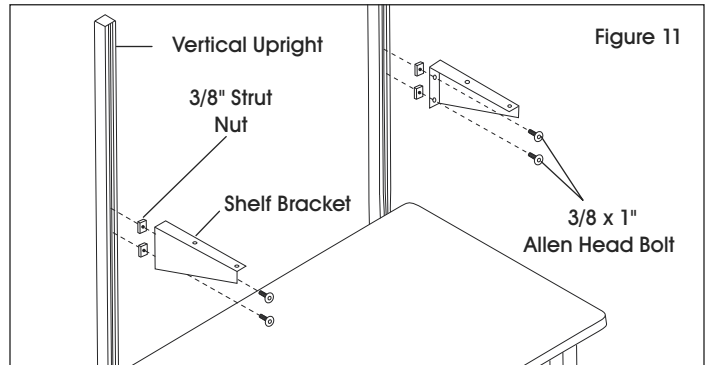

2. Lay 12 x 60" ESD shelf on brackets with equal overhang on each side.
3. With second person, install 3/4" wood screws into underside of shelf support beam ends and through shelf support brackets to secure shelf. (See Figure 12)
4. Install remainder of 3/4" wood screws to secure shelf to shelf support beam. (See Figure 12)

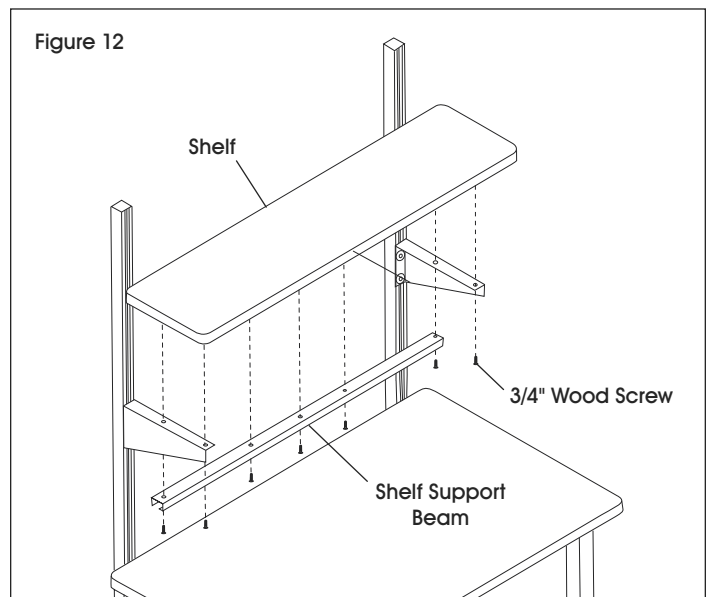

# ASSEMBLY CONTINUED

## ELECTRICAL STRIP

1. Attach electrical strip mounting rail to vertical uprights using 3/8 x 1" Allen head bolts and 3/8" strut nuts. (See Figure 13)

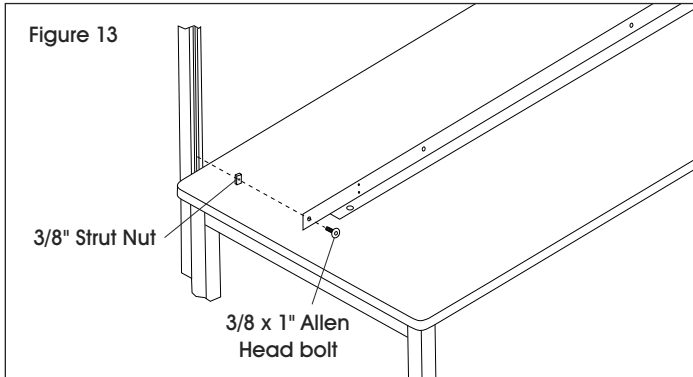

2. Attach electrical strip to mounting rail using 3/16 x 3/8" round head bolts and 3/16" nuts. (See Figure 14)

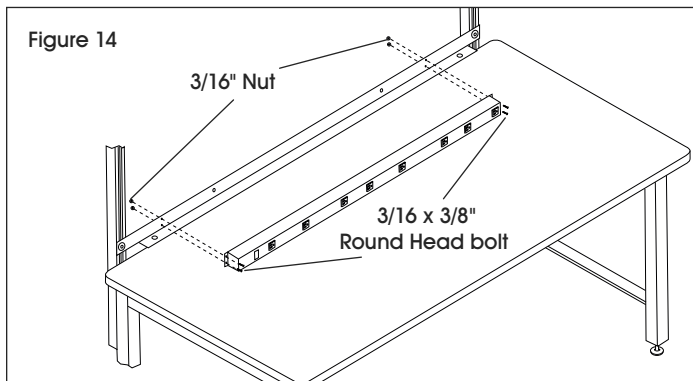

## BIN HOLDER

1. Attach metal bin holder to vertical uprights at desired height using 3/8 x 1" Allen head bolts and 3/8" strut nuts. (See Figure 15)

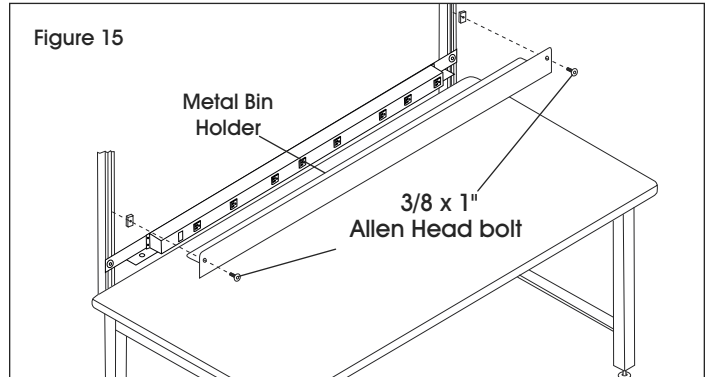

**IMPORTANT!** When assembly is complete, install the blue ring terminal to the center of a grounded outlet by attaching to center screw. See "Wiring Benchtop" on Pages 3-4.



**ULINE**

1-800-295-5510  
uline.com

# ULINE H-2043

## MESA DE TRABAJO ANTIESTÁTICA

800-295-5510  
uline.mx

### HERRAMIENTAS NECESARIAS



Se recomienda Armar Entre Dos Personas

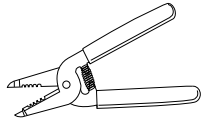

Pinza Pelacables

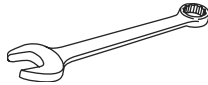

Llave de 7/16"

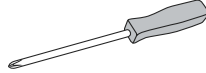

Desarmador de Cruz



Llave Allen de 3/16"  
Llave Allen de 1/8"  
(Incluidas)

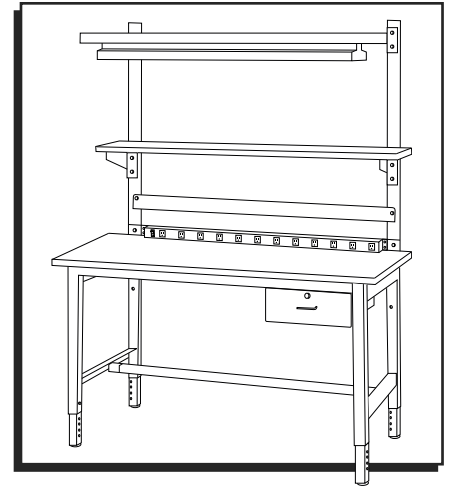

### PARTES

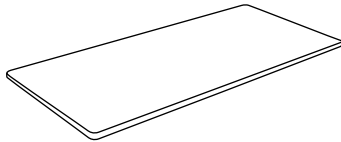

1 Cubierta de Mesa

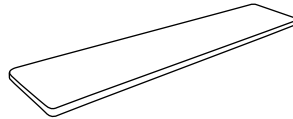

1 Repisa

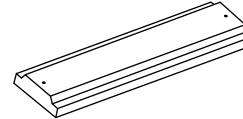

1 Lámpara

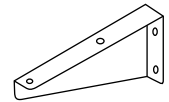

2 Soportes de Repisa

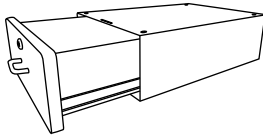

1 Ensamble de Cajón

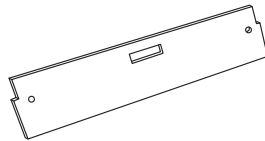

1 Soporte de Instalación para Cajón Frontal

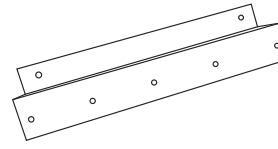

1 Soporte de Instalación para Cajón Posterior

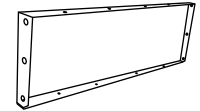

1 Riel Posterior

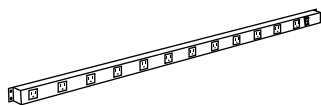

1 Multicontacto de 48"

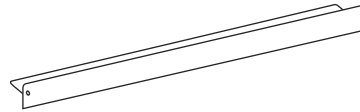

1 Portagavetas de Metal

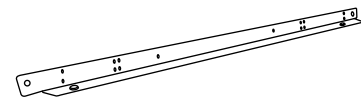

1 Riel de Instalación para Multicontacto

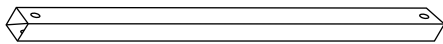

1 Barra Transversal de Reposapiés

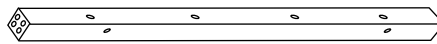

1 Riel Frontal

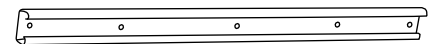

1 Viga de Soporte para Repisa



2 Postes Verticales



1 Viga de Soporte para Lámpara

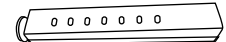

4 Extensores de Pata

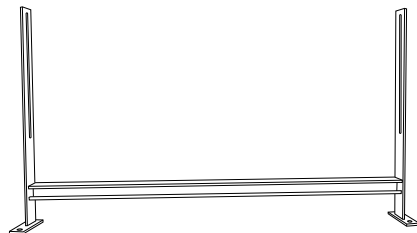

1 Armazón de Soporte para Lámpara

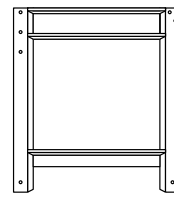

2 Ensamblajes de Pata

# TORNILLERÍA



4 Pernos de Cabeza Hexagonal de 1/4 x 2 3/4"



1 Perno de Cabeza Hexagonal de 5/16 x 2 1/2"



6 Pernos de Cabeza Hexagonal de 1/4 x 3/4"

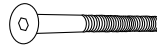

2 Pernos de Cabeza Plana Allen de 3/4 x 2 3/4"

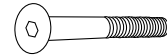

2 Pernos de Cabeza Plana Allen de 3/16 x 2 1/4"



12 Pernos de Cabeza Allen de 3/8 x 1"

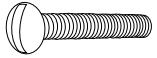

4 Pernos de Cabeza Redonda de 3/16 x 2 3/8"



4 Pernos de Cabeza Redonda de 3/16 x 3/8"



25 Tornillos para Madera de 3/4"



4 Tuercas Cerradas de 3/16"



4 Contratuercas de 3/16"



8 Contratuercas de 1/4"

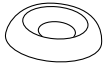

4 Rondanas para Acabado de 1/4"



3 Rondanas Planas de 5/16" (2 delgadas, 1 gruesa)  
22 Rondanas Planas de 1/4"



1 Rondana Serrada de 5/16"



4 Rondanas de Seguridad de 3/16"



4 Tuerca de 3/16"



3 Tuercas de 5/16" (2 delgadas, 1 gruesa)



3 Anillo de la Terminal



4 Cinchos

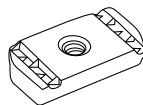

4 Tuercas Deslizantes de 1/4"

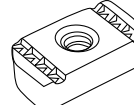

12 Tuercas Deslizantes de 3/8"

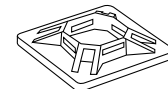

4 Láminas Autoadhesivas

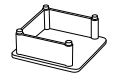

4 Tapas para Extremos

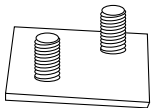

2 Placas de Unión de 2 x 2"

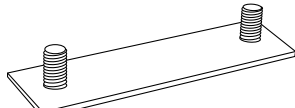

2 Placas de Unión de 1 x 3 7/8"

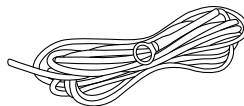

1 Atado de Cable Con Terminal de Anillo Precableado

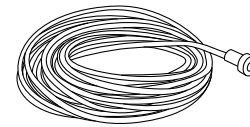

2 Enchufes Precableados de 5/16"



1 Cinta Adhesiva Protectora para Reposapiés

# ENSAMBLE

## ARMAZÓN

1. Fije el riel frontal y posterior a los ensambles de las patas utilizando las placas de unión y las contratuercas de 1/4". Asegúrese de que el lado del riel con cuatro orificios apunte hacia la parte superior de la mesa. (Vea Diagrama 1)



**¡IMPORTANTE!** Asegúrese de que los rieles frontales y posteriores queden a ras con la parte superior de los ensambles de las patas y empujados hacia adentro aproximadamente 1/8" para permitir que la cubierta de la mesa se instale adecuadamente.

2. Asegure los orificios más bajos del riel posterior a los ensambles de las patas con pernos de cabeza hexagonal de 1/4" x 3/4" y rondanas planas de 1/4".
3. Apriete todos los pernos y tuercas. (Vea Diagrama 1)

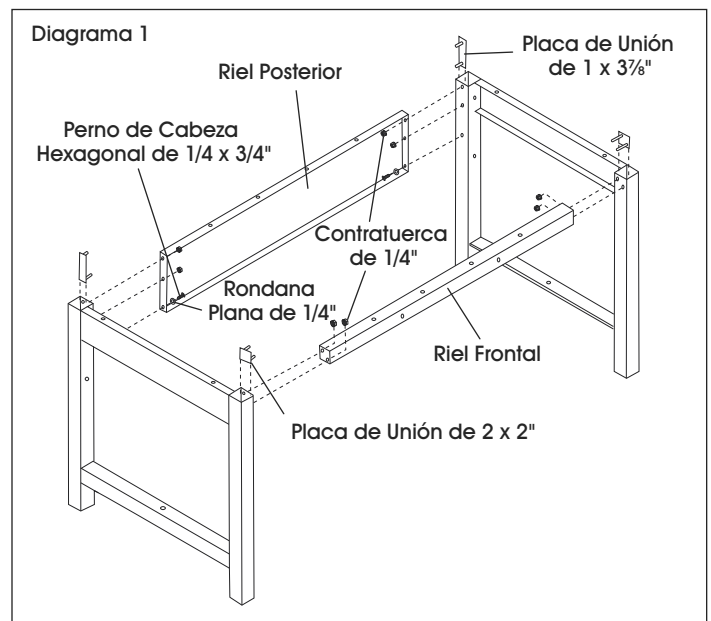



## CONTINUACIÓN DEL ENSAMBLE

- Coloque la cubierta de la mesa con la parte inferior hacia arriba en una superficie plana que no deje marcas. Coloque el armazón ensamblado boca abajo encima de la cubierta de la mesa.

 **NOTA:** El riel posterior debe quedar a ras con el borde de la cubierta y más cerca del orificio preperforado de la cubierta.

- Alinee los orificios guía de la cubierta con los orificios del armazón ensamblado. Asegure con tornillos para madera de 3/4". (Vea Diagrama 2)

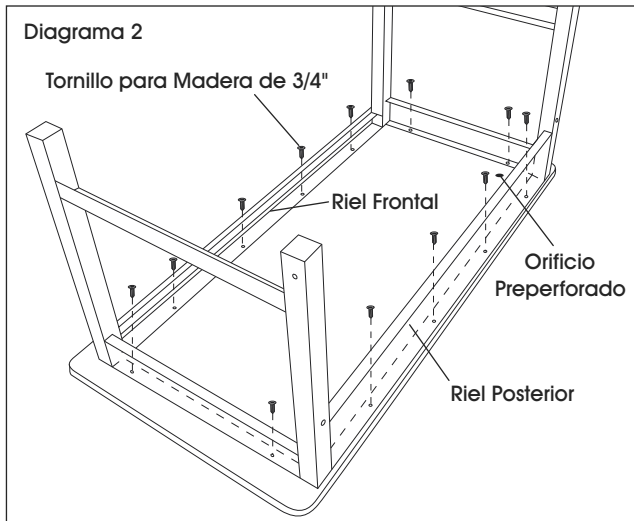

- Inserte los extensores de pata en cada pata, seleccione la altura deseada e inserte un perno de cabeza redonda de 3/16 x 2 3/8" y rondana plana de 1/4" por pata. (Vea Diagrama 3)
- Asegure el perno de cabeza redonda con una rondana plana de 1/4", rondana de seguridad de 3/16 y tuerca cerrada de 3/16 en el lado opuesto. (Vea Diagrama 3)

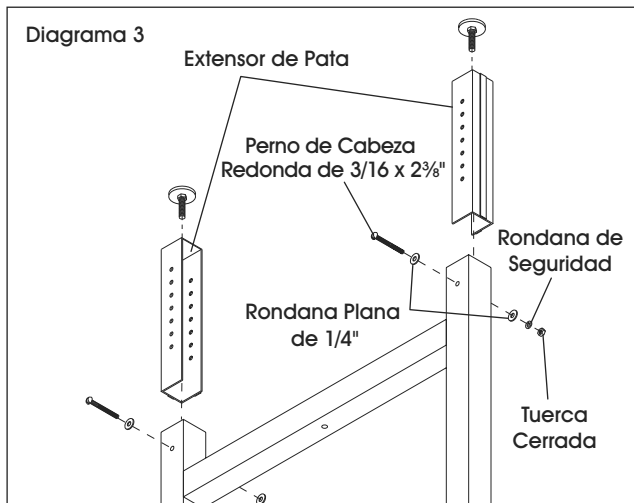

## CABLEADO DE LA CUBIERTA DE LA MESA

- Instale la siguiente tornillería en el orificio preperforado de la cubierta de la mesa en el siguiente orden. (Vea Diagrama 4)

**Encima de la cubierta:** Rondana serrada de 5/16" (A), terminal de anillo liso (B), perno de cabeza hexagonal de 5/16 x 2 1/2" (C)

**Debajo de la cubierta:** rondana plana delgada de 5/16" (D), terminal de anillo con alambre (E), rondana plana delgada de 5/16" (F), terminal de anillo amarillo (G), rondana plana gruesa de 5/16" (H), tuerca gruesa de 5/16" (I)

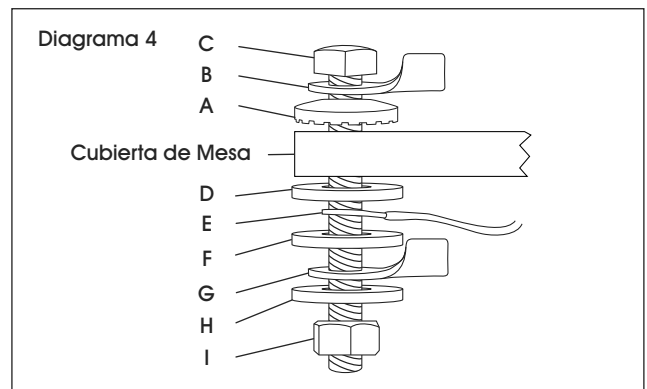

- Apriete la tuerca de 5/16".
- Inserte los enchufes precableados en los orificios del riel frontal. Instale usando tuercas delgadas de 5/16". (Vea Diagrama 5)
- Pase los cables del enchufe precableado de 5/16" a la terminal de anillo amarillo a lo largo de la parte inferior de la cubierta. Use las láminas autoadhesivas y cinchos para asegurarlos. (Vea Diagrama 5)

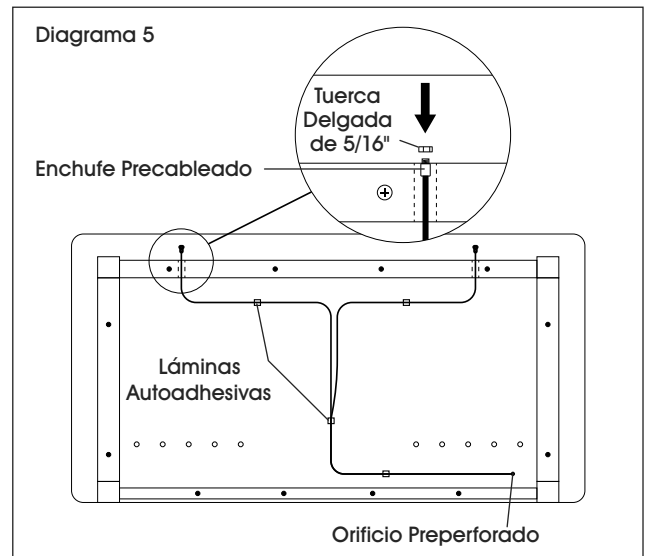

## CONTINUACIÓN DEL ENSAMBLE

5. Corte el cable al largo apropiado dejando aproximadamente 1-2" de margen adicional. Pele los cables de los enchufes 1/4" y conéctelos a la terminal de anillo engarzando los cables en la terminal.
6. Pele el extremo del cable de la terminal de anillo precableado e insértelo en el terminal azul. Engarce la terminal de anillo azul.



**¡IMPORTANTE!** Cuando el ensamble está terminado, instale la terminal de anillo azul al centro de una toma de corriente con conexión a tierra fijándolo al tornillo central.



**NOTA:** La mesa para trabajo debe permanecer boca abajo después de que la cubierta de la mesa se haya cableado.

## CAJÓN

1. Saque el cajón lo más lejos posible de su cubierta. Deslice las palancas de los rieles laterales del cajón y jale para sacarlo completamente.
2. Asegure las placas de instalación frontal y posterior a la cubierta del cajón utilizando los pernos de cabeza hexagonal de 1/4" x 3/4" y las rondanas planas de 1/4". Apriete los pernos en la placa de instalación posterior y deje flojos los de la placa de instalación frontal. (Vea Diagrama 6)



**NOTA:** La placa de instalación frontal del cajón debe superponerse al riel frontal por 1".

3. Asegure la placa de instalación posterior a la cubierta de la mesa utilizando cinco tornillos para madera de 3/4" a través de los orificios guía de la cubierta de la mesa. Apriete los pernos de cabeza hexagonal anteriormente instalados en la placa de instalación frontal. Deslice el cajón dentro de la carcasa. (Vea Diagrama 6)

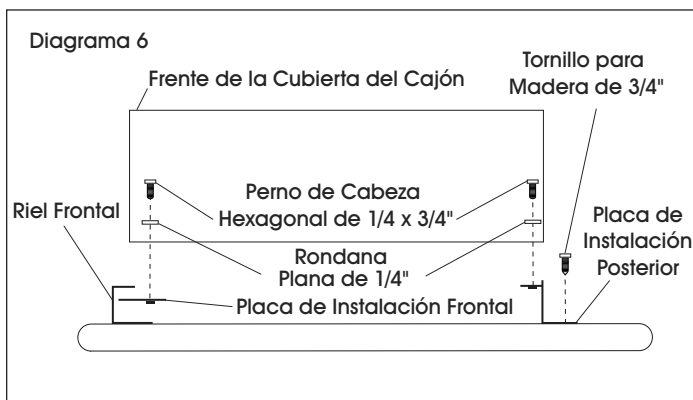

## REPOSAPIÉS

1. Voltee la mesa de trabajo hacia arriba.
2. Retire el respaldo de cera del lado adhesivo de la cinta adhesiva protectora para reposapiés. Centre la cinta adhesiva protectora para reposapiés a lo largo del mismo. Presione firmemente la cinta al reposapiés. (Vea Diagrama 7)
3. Fije el reposapiés a los ensambles de patas usando los pernos de cabeza plana Allen de 3/16 x 2 1/4", rondanas para acabado de 1/4", rondanas planas de 1/4" y contratuercas de 3/16". (Vea Diagrama 7)

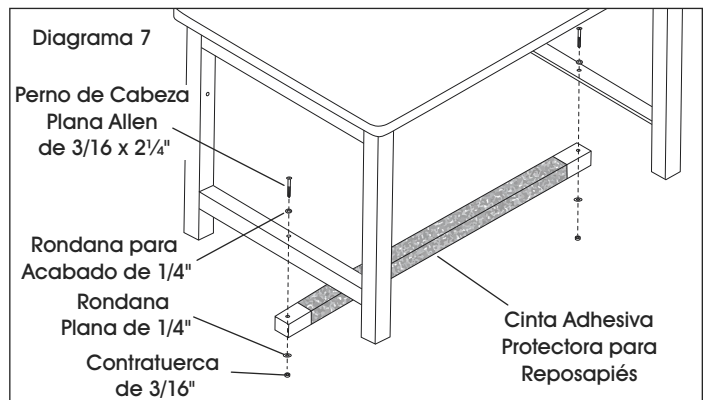

## POSTES VERTICALES

1. Coloque dos rondanas planas de 1/4" en dos pernos de cabeza hexagonal de 1/4 x 2 3/4". Inserte los pernos a través de la pata posterior en la ubicación deseada. (Vea Diagrama 8)
2. Enrosque una tuerca deslizante de 1/4" en el perno de cabeza hexagonal de 1/4 x 2 3/4" anteriormente instalado. Gire aproximadamente dos hilos de rosca. (Vea Diagrama 8)
3. Sostenga los postes verticales contra la parte posterior de las patas posteriores. Inserte las tuercas deslizantes en los postes y gírelas en el sentido de las manecillas del reloj para asegurarlas dentro del poste. Apriete los pernos de cabeza hexagonal. (Vea Diagrama 8)

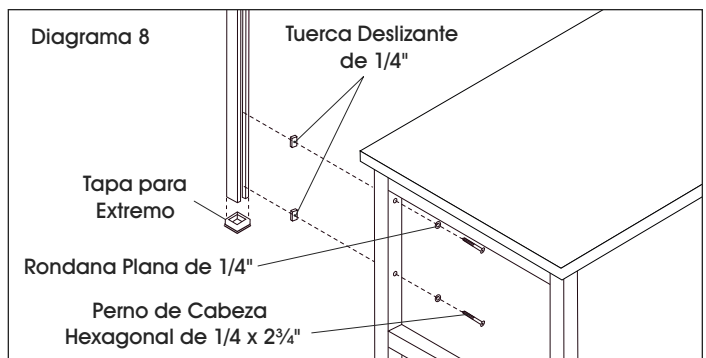

## CONTINUACIÓN DEL ENSAMBLE

 **NOTA:** Deje al menos 12" del poste por debajo de la cubierta de la mesa para estabilizarla y asegurarla.

4. Repita la operación en el poste restante.

### LÁMPARA

1. Con ayuda de otra persona, fijen el armazón de soporte para lámpara a los postes verticales utilizando los pernos de cabeza Allen de 3/8 x 1" y las tuercas deslizantes de 3/8". (Vea Diagrama 9)

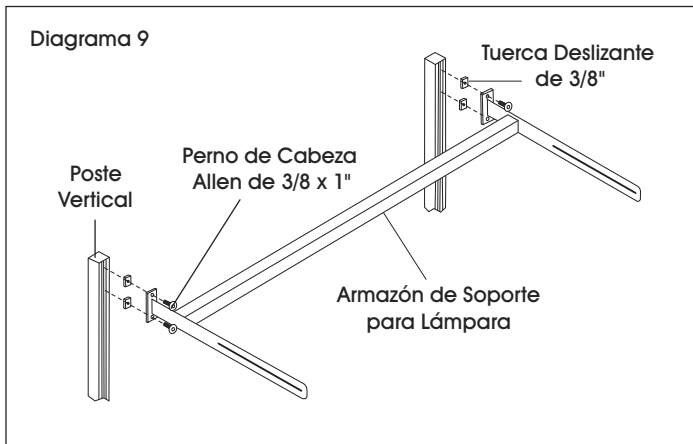

2. Fije la lámpara a la viga de soporte utilizando pernos de cabeza Allen de 3/16 x 2 3/4", rondanas para acabado de 1/4", rondanas planas de 1/4", y contratuercas de 3/16". (Vea Diagrama 10)

 **NOTA:** Retire las entradas de la lámpara antes de fijarla a la viga de soporte.

3. Instale la viga de soporte para lámpara al armazón de soporte para lámpara utilizando rondanas de plástico grandes, chicas y perillas. (Vea Diagrama 10)

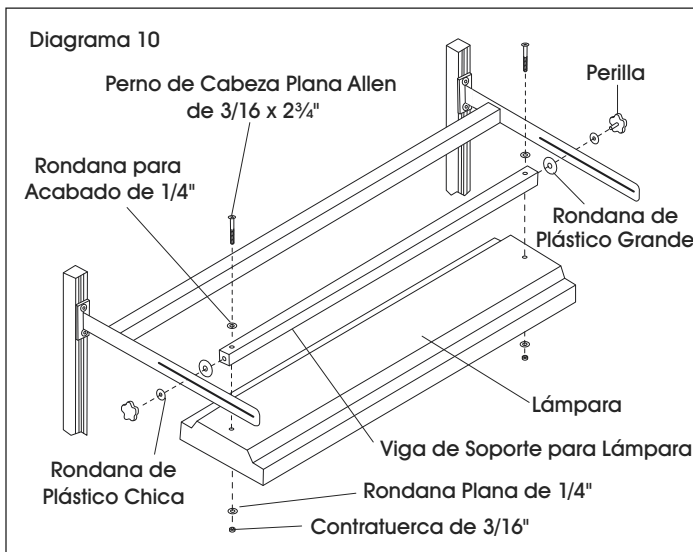

### REPISA

1. Escoja la altura deseada en los postes verticales e instale soportes para repisa utilizando perno de cabeza Allen de 3/8 x 1" y tuercas deslizantes de 3/8". (Vea Diagrama 11)

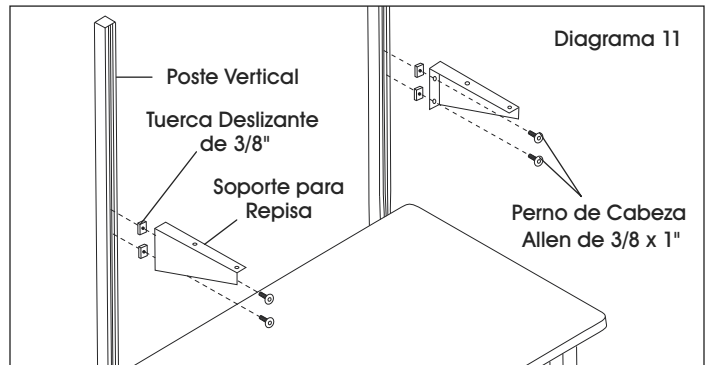

2. Coloque la repisa ESD de 12 x 60" en los soportes, asegurando que sobresalga de la misma manera a cada lado.
3. Con ayuda de otra persona, instale tornillos para madera de 3/4" en el lado inferior de los extremos de las vigas y a través de los brazos de soporte para asegurar la repisa. (Vea Diagrama 12)
4. Instale el resto de los tornillos para madera de 3/4" para asegurar la repisa a la viga de soporte para repisa. (Vea Diagrama 12)

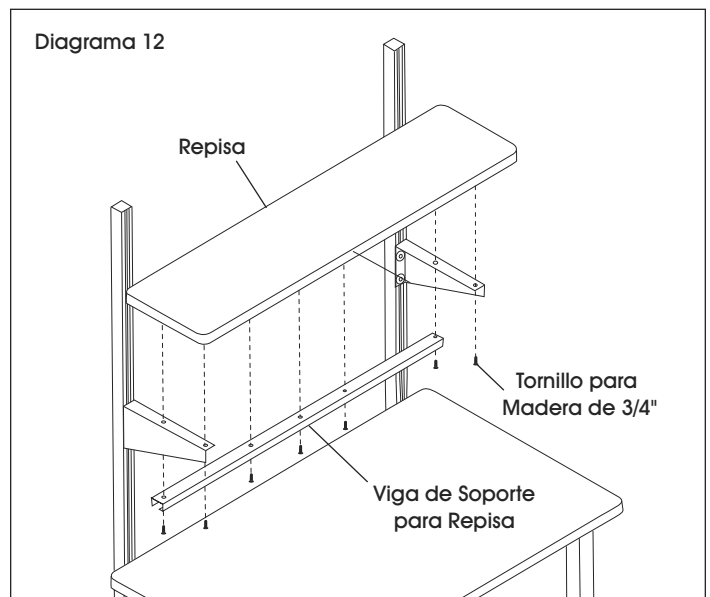

# CONTINUACIÓN DEL ENSAMBLE

## MULTICONTACTOS

1. Fije el riel de instalación para multicontacto a los postes verticales utilizando pernos de cabeza Allen de 3/8 x 1" y tuercas deslizantes de 3/8". (Vea Diagrama 13)

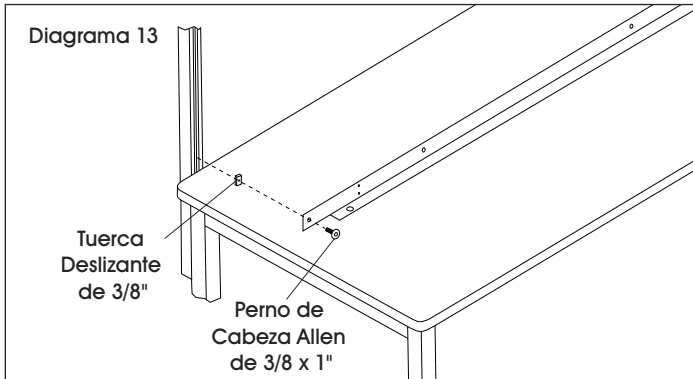

2. Fije el multicontacto al riel de instalación para multicontacto utilizando pernos de cabeza redonda de 3/16 x 3/8" y tuercas deslizantes de 3/16". (Vea Diagrama 14)

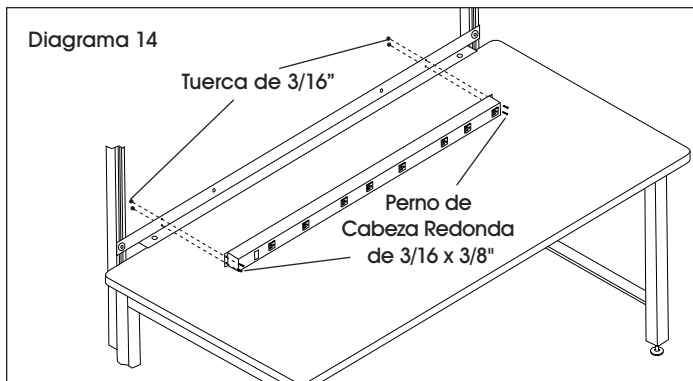

## PORTAGAVETAS

1. Fije el portagavetas de metal a los postes verticales utilizando pernos de cabeza Allen de 3/8 x 1" y tuercas deslizantes de 3/8". (Vea Diagrama 15)

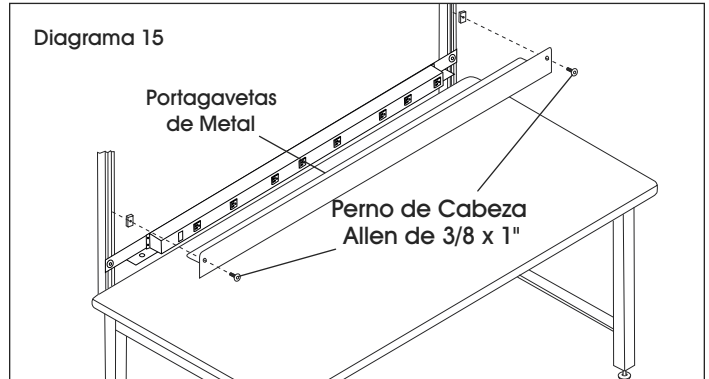

**¡IMPORTANTE!** Cuando el ensamble está terminado, instale la terminal de anillo azul al centro de una toma de corriente con conexión a tierra fijándolo al tornillo central. Vea "Cableado de la Cubierta de la Mesa" en las Páginas 9-10.



**ULINE**

800-295-5510  
uline.mx

# ULINE H-2043

## ÉTABLI ANTISTATIQUE

1-800-295-5510  
uline.ca

### OUTILS REQUIS



Montage à deux personnes recommandé

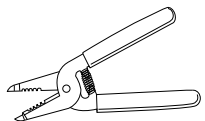

Pince à dénuder

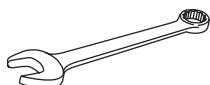

Clé de 7/16 po

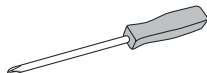

Tournevis cruciforme



Clé Allen de 3/16 po  
Clé Allen de 1/8 po (inclus)

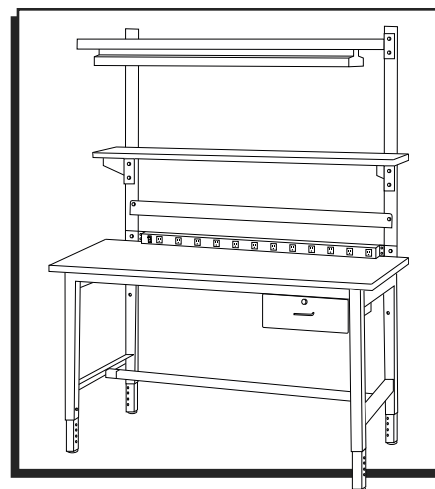

### PIÈCES

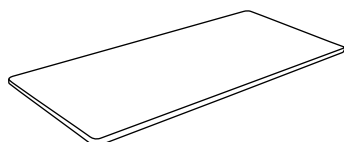

Surface d'établi x 1

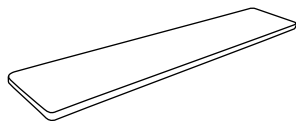

Tablette x 1

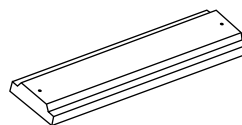

Luminaire x 1

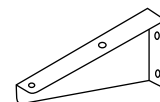

Console de tablette x 2

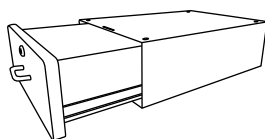

Ensemble du tiroir x 1

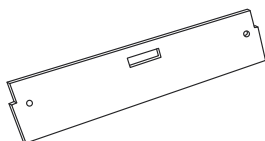

Plaque de montage avant du tiroir x 1

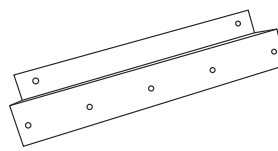

Plaque de montage arrière du tiroir x 1

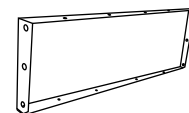

Rail arrière x 1

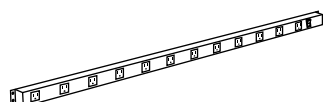

Barre multiprise de 48 po x 1

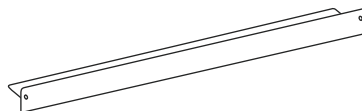

Porte-bacs en métal x 1

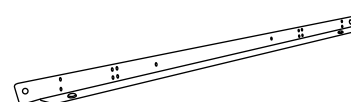

Rail de montage pour barre multiprise x 1

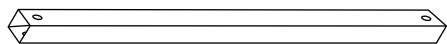

Barre de repose-pied x 1

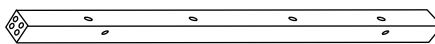

Rail avant x 1

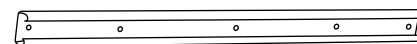

Barre de support de la tablette x 1



Montant vertical x 2

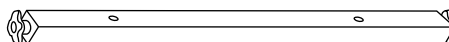

Barre de support du luminaire x 1

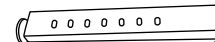

Rallonge de pied x 4

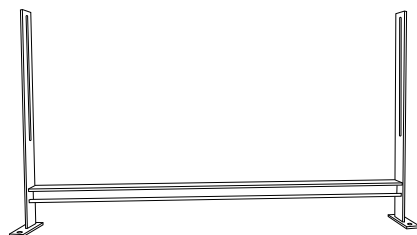

Cadre de support du luminaire x 1

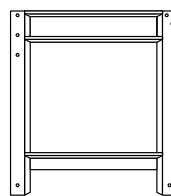

Ensemble de pied x 2

# MATÉRIEL D'INSTALLATION

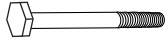

Boulon hexagonal de 1/4 po x 2 3/4 po x 4



Boulon hexagonal de 5/16 x 2 1/2 po x 1



Boulon hexagonal de 1/4 x 3/4 po x 6

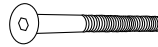

Boulon Allen plat de 3/16 x 2 3/4 po x 2

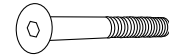

Boulon Allen plat de 3/16 x 2 1/4 po x 2



Boulon Allen de 3/8 x 1 po x 12

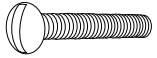

Boulon rond de 3/16 x 2 3/8 po x 4



Boulon rond de 3/16 x 3/8 po x 4



Vis à bois de 3/4 po x 25



Écrou borgne de 3/16 po x 4



Écrou freiné de 3/16 po x 4



Écrou freiné de 1/4 po x 8



Rondelle cuvette de 1/4 po x 4



Rondelle plate de 5/16 po x 3 (fin x 2, épais x 1)  
Rondelle plate de 1/4 po x 22



Rondelle dentelée de 5/16 po x 1



Rondelle de blocage de 3/16 po x 4



Écrou de 3/16 po x 4



Écrou de 5/16 po x 3 (fin x 2, épais x 1)



Cosse à anneau x 3



Attache-câble x 4

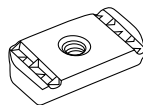

Écrou de rail de 1/4 po x 4

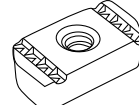

Écrou de rail de 3/8 po x 12

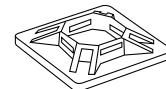

Tampon autoadhésif x 4

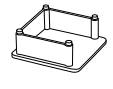

Embout x 4

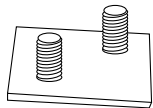

Plaque de renforcement de 2 x 2 po x 2

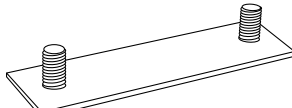

Plaque de renforcement de 1 x 3 7/8 po x 2

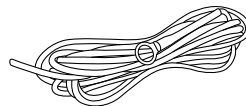

Faisceau de câble avec cosse à anneau câblée x 1

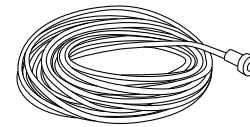

Fiche câblée de 5/16 po x 2



Ruban adhésif de protection pour repose-pied x 1

# MONTAGE

## CADRE

1. Fixez sans serrer les rails avant et arrière aux ensembles de pied avec des plaques de renforcement et des écrous freinés de 1/4 po. Assurez-vous que le côté du rail avec quatre trous est orienté vers le haut de l'établi. (Voir Figure 1)



**IMPORTANT!** Assurez-vous que les rails avant et arrière sont de niveau avec le dessus des ensembles de pied et qu'ils sont poussés d'environ 1/8 po vers l'intérieur pour permettre le montage de la surface d'établi.

2. Insérez des boulons de 1/4 x 3/4 po et des rondelles plates de 1/4 po dans les trous du rail arrière au niveau le plus bas pour les fixer aux ensembles de pieds.
3. Serrez tous les écrous et les boulons. (Voir Figure 1)

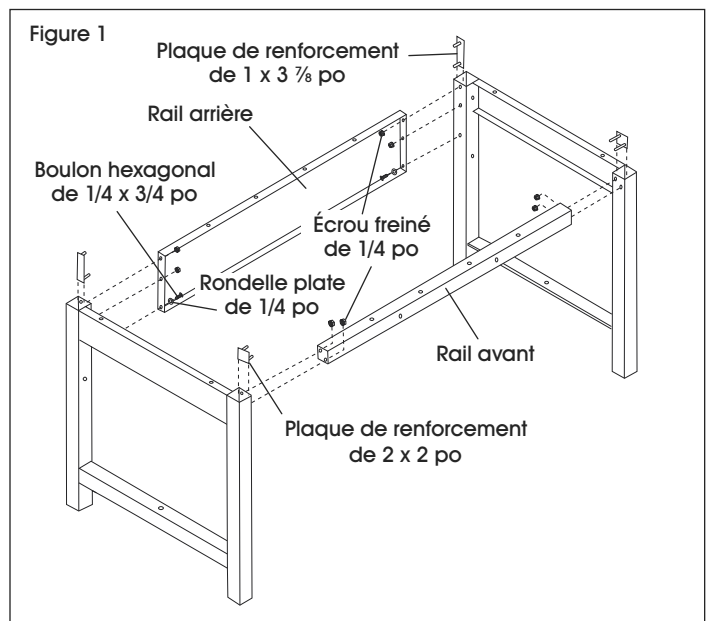

- Placez la surface d'établi, face inférieure vers le haut, sur une surface plane qui ne raye pas. Placez le cadre assemblé à l'envers sur la surface d'établi.



**REMARQUE :** Le rail arrière doit être de niveau avec le bord de la surface et proche du trou prépercé dans la surface d'établi.

- Alignez les avant-trous de la surface d'établi sur les trous du cadre assemblé. Fixez le tout avec des vis à bois de 3/4 po. (Voir Figure 2)

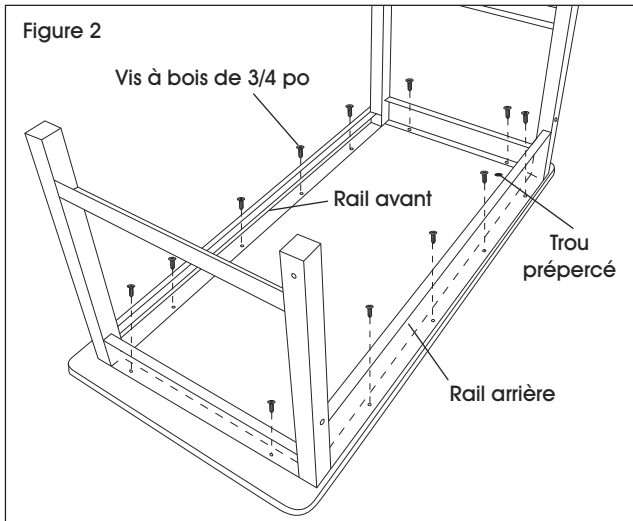

- Insérez les rallonges de pied dans chacun des pieds, choisissez la hauteur voulue et insérez un boulon rond de 3/16 x 2 3/8 po et une rondelle plate de 1/4 po par pied. (Voir Figure 3)
- Fixez un boulon rond avec une rondelle plate de 1/4 po, une rondelle de blocage de 3/16 po et un écrou borgne de 3/16 po sur l'autre côté. (Voir Figure 3)

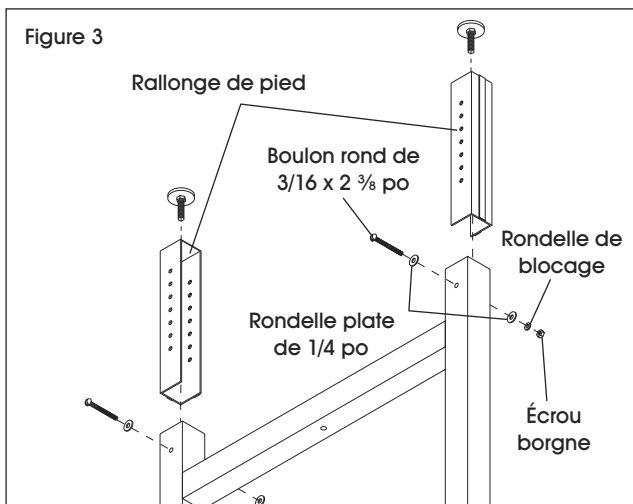

## CÂBLAGE DE LA SURFACE D'ÉTABLI

- Installez le matériel suivant dans le trou prépercé de la surface d'établi dans l'ordre indiqué qui suit. (Voir Figure 4)

**Au-dessus de la surface d'établi :** rondelle dentelée de 5/16 po (A), cosse à anneau simple (B), boulon hexagonal de 5/16 x 2 1/2 po (C)

**En dessous de la surface d'établi :** rondelle plate fine de 5/16 po (D), cosse à anneau câblée (E), rondelle plate fine de 5/16 po (F), cosse à anneau jaune (G), rondelle plate épaisse de 5/16 po (H), écrou épais de 5/16 po (I)

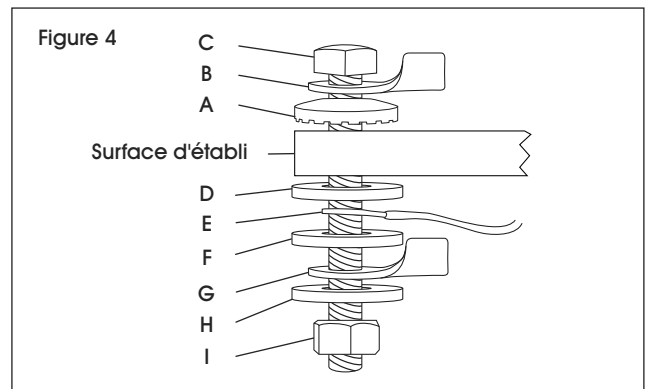

- Fixez le tout avec un écrou de 5/16 po.
- Insérez les fiches câblées dans les trous du rail avant. Effectuez le montage avec des écrous de 5/16 po. (Voir Figure 5)
- Acheminez les fils des fiches câblées de 5/16 po sous la surface de table jusqu'à la cosse à anneau jaune. Servez-vous de tampons autoadhésifs et d'attache-câbles pour fixer le tout. (Voir Figure 5)

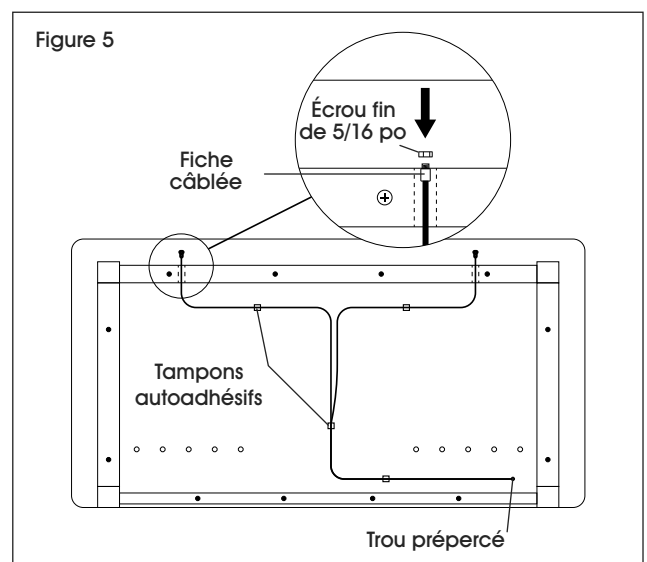

## MONTAGE SUITE

- Coupez les fils à la longueur appropriée en laissant environ 1 à 2 po de mou. Dénudez les fils des fiches de 1/4 po et connectez-les à la cosse à anneau en effectuant un sertissage aux cosses.
- Dénudez le bout du fil sur la cosse à anneau câblée et insérez-le dans la cosse à anneau bleue. Effectuez un sertissage sur la cosse à anneau bleue.



**IMPORTANT!** Une fois le montage complété, installez la cosse à anneau bleue au centre d'une prise mise à la terre en la reliant à la vis centrale.



**REMARQUE :** Laissez l'établi à l'envers après avoir effectué le câblage de la surface.

### TIROIR

- Ouvrez et étirez le tiroir le plus possible. Faites glisser les leviers noirs des glissières latérales et sortez complètement le tiroir de son compartiment.
- Fixez les plaques de montage avant et arrière au compartiment du tiroir avec des boulons hexagonaux de 1/4 x 3/4 po et de rondelles plates de 1/4 po. Serrez les boulons de la plaque de montage arrière et laissez ceux de la plaque avant légèrement desserrés. (Voir Figure 6)



**REMARQUE :** La plaque de montage avant du tiroir doit dépasser le rail avant de 1 po.

- Fixez la plaque de montage arrière avec cinq vis à bois de 3/4 po en utilisant les avant-trous situés sur la surface d'établi. Serrez les boulons hexagonaux précédemment installés sur la plaque de montage avant. Glissez le tiroir dans le compartiment. (Voir Figure 6)

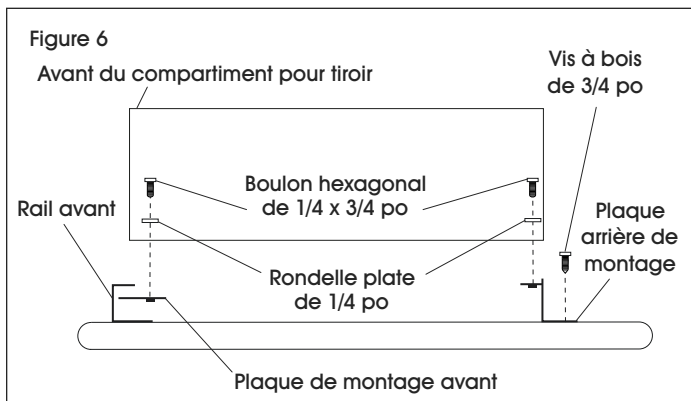

### REPOSE-PIED

- Redressez l'établi.

- Découpez la doublure de cire du ruban adhésif de protection pour repose-pied. Placez le ruban adhésif de protection bien au centre sur la longueur du repose-pied. Appliquez-le fermement sur le repose-pied. (Voir Figure 7)

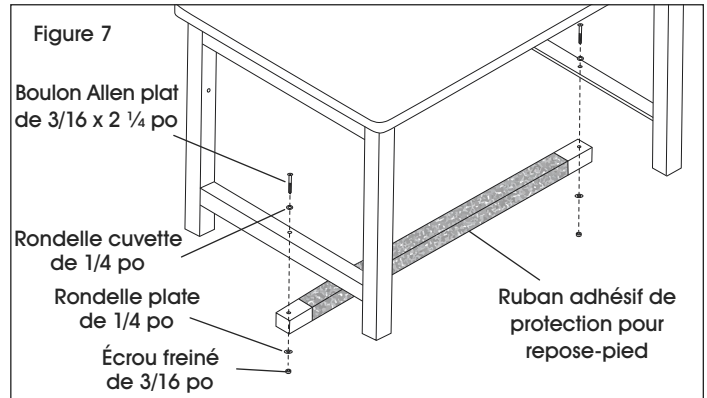

- Fixez le repose-pied aux ensembles de pied avec des boulons Allen plats de 3/16 x 2 1/4 po, des rondelles cuvettes de 1/4 po, des rondelles plates de 1/4 po et des écrous freinés de 3/16 po. (Voir Figure 7)

### MONTANTS VERTICAUX

- Placez deux rondelles plates de 1/4 po sur deux boulons hexagonaux de 1/4 x 2 3/4 po. Insérez les boulons à travers le pied arrière à l'emplacement voulu. (Voir Figure 8)
- Enfilez un écrou de rail de 1/4 po sur le boulon de 1/4 x 2 3/4 po précédemment installé. Faites deux tours de filetage. (Voir Figure 8)
- Maintenez les montants verticaux au dos des pieds arrière. Insérez les écrous de rail dans les montants et tournez-les dans le sens horaire pour les fixer. Serrez les boulons hexagonaux. (Voir Figure 8)

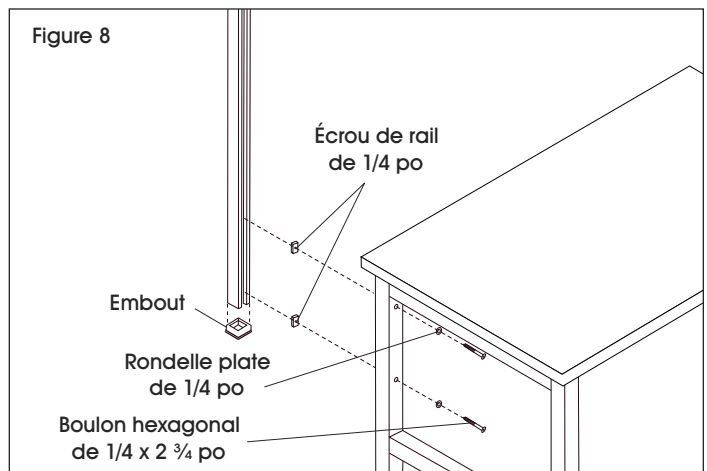



# MONTAGE SUITE

 **REMARQUE :** Pour rendre les établis sûrs et stables, une longueur de 12 po sur le montant doit se trouver en dessous de la surface d'établi.

4. Répétez la procédure pour l'autre montant.

## LUMINAIRE

1. À deux, fixez le cadre de support du luminaire aux montants verticaux avec des boulons Allen de 3/8 x 1 po et des écrous de rail de 3/8 po. (Voir Figure 9)

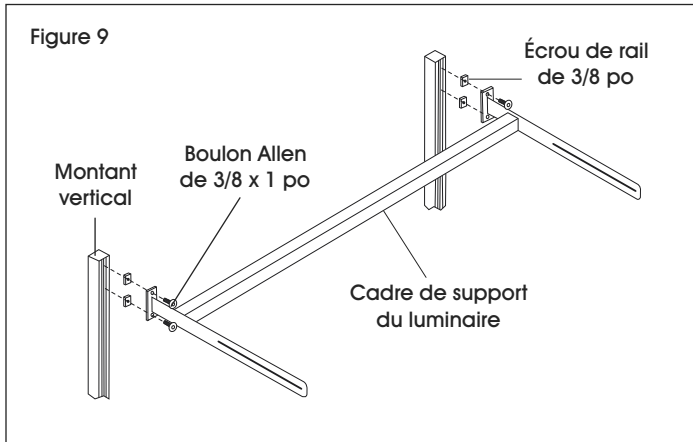

2. Fixez le luminaire à sa barre de support avec des boulons Allen de 3/16 x 2 3/4 po des rondelles cuvettes de 1/4 po, des rondelles plates de 1/4 po et des écrous freinés de 3/16 po. (Voir Figure 10)

 **REMARQUE :** Enlevez les entrées défonçables du luminaire avant de le fixer à la barre de support.

3. Fixez la barre de support du luminaire au cadre de support du luminaire avec les petites et les grandes rondelles en plastique et les molettes. (Voir Figure 10)

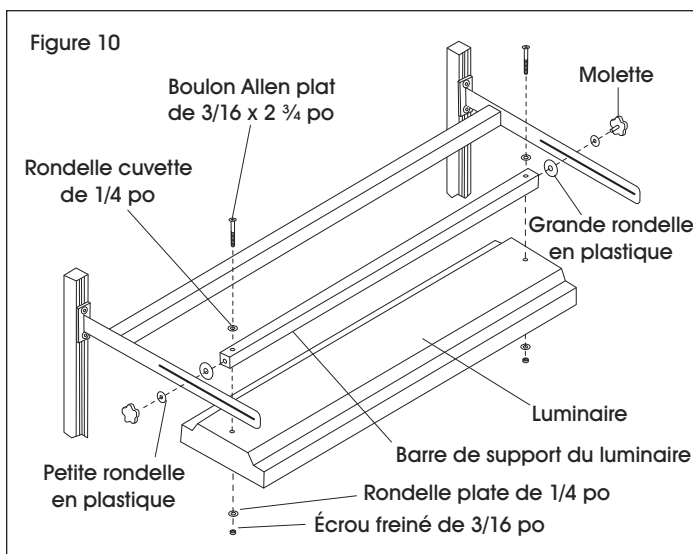

## TABLETTE

1. Choisissez la hauteur voulue sur les montants verticaux et fixez les consoles de tablette avec des boulons Allen de 3/8 x 1 po et des écrous de rail de 3/8 po. (Voir Figure 11)

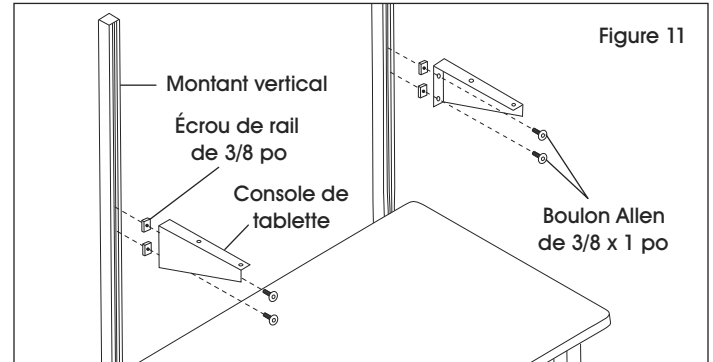

2. Posez la tablette DES de 12 x 60 po sur les consoles en la centrant des deux côtés.

3. À deux, installez des vis à bois de 3/4 po aux extrémités sous la barre de support, puis à travers les consoles pour fixer la tablette. (Voir Figure 12)

4. Installez le reste des vis à bois de 3/4 po pour fixer complètement la tablette à la barre de support. (Voir Figure 12)

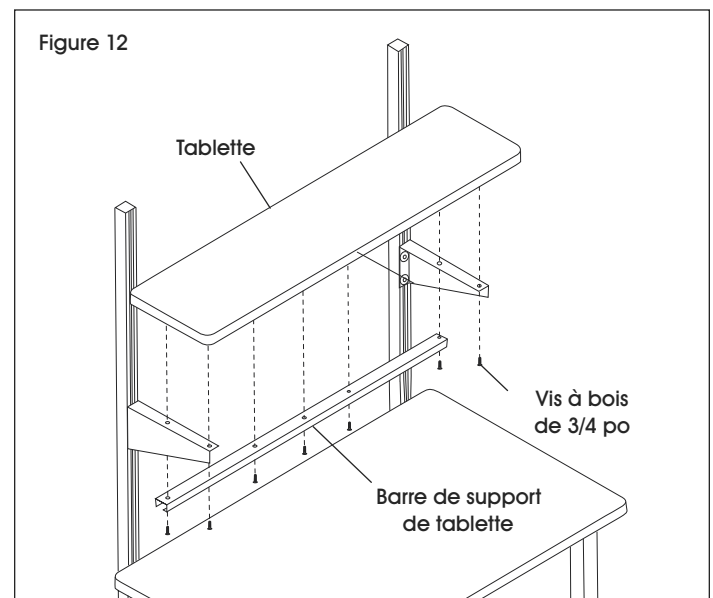

# MONTAGE SUITE

## BARRE MULTIPRISE

1. Fixez le rail de montage de la barre multiprise aux montants verticaux avec des boulons Allen de 3/8 x 1 po et des écrous de rail de 3/8 po. (Voir Figure 13)

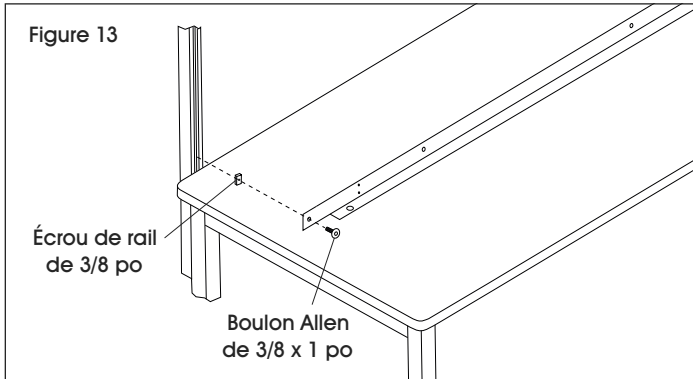

2. Fixez la barre multiprise au rail de montage avec des boulons ronds de 3/16 x 3/8 po et des écrous de 3/16 po. (Voir Figure 14)

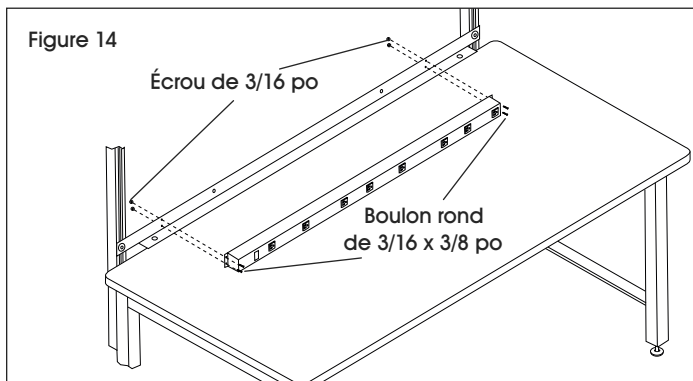

## PORTE-BACS

1. Fixez le porte-bacs en métal aux montants verticaux à la hauteur voulue avec des boulons Allen de 3/8 x 1 po et des écrous de rail de 3/8 po. (Voir Figure 15)

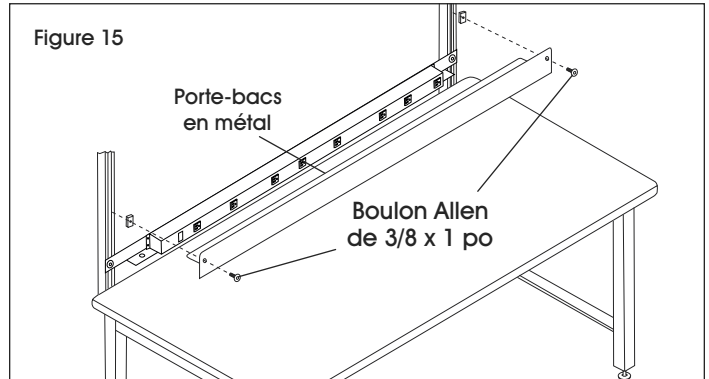

**IMPORTANT!** Une fois le montage complété, installez la cosse à anneau bleue au centre d'une prise mise à la terre en la reliant à la vis centrale. Voir la section Câblage de la surface d'établi, pages 15 et 16.



**ULINE**

1-800-295-5510  
uline.ca