

# ULINE H-2323

## SWINGLINE® LIGHT TOUCH™ HEAVY DUTY DESKTOP MANUAL STAPLER

1-800-295-5510  
uline.com

### COMPATIBLE STAPLES

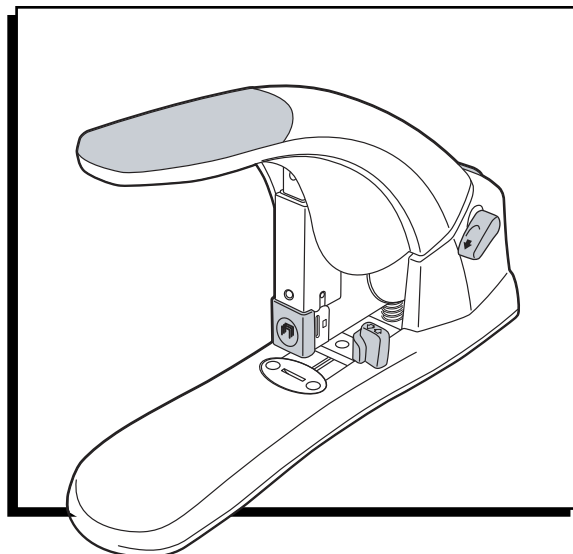
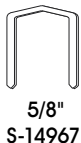

## OPERATION

1. Push load button to release magazine. (See Figure 1)

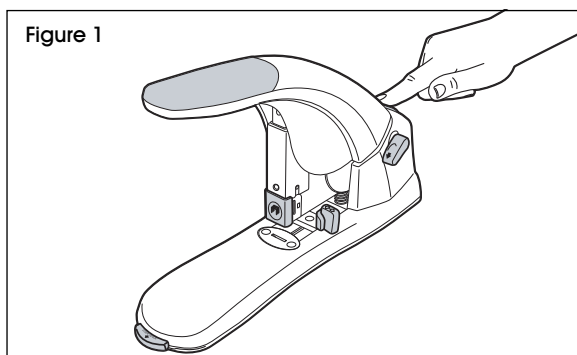

2. Pull the magazine all the way out until it stops. (See Figure 2)

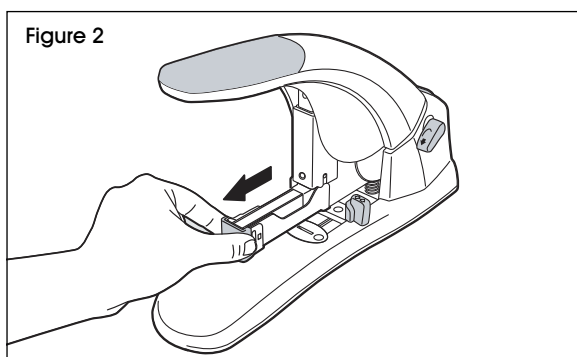

3. Load 5/8" Heavy Duty Staples (Uline model # S-14967). (See Figure 3)

4. Push magazine closed until you hear an audible click.

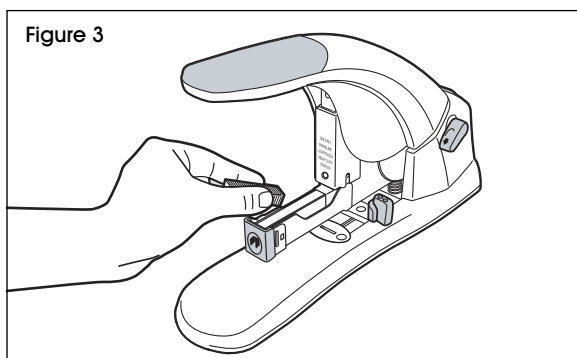

## OPERATION CONTINUED

5. To adjust paper depth, move depth guides forward to unlock. Adjust paper depth guide to desired position and move guides backward to lock depth guide in place. (See Figure 4)

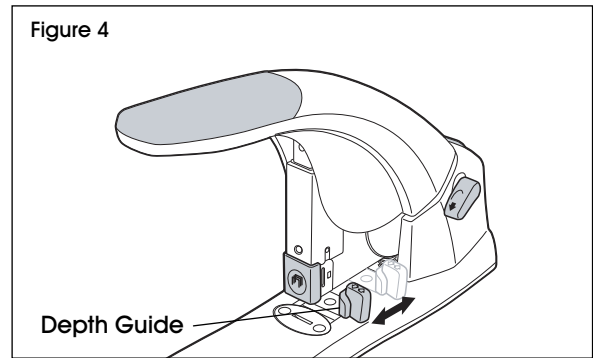

6. Insert paper into paper depth guide as shown for angled stapling. (See Figure 5)

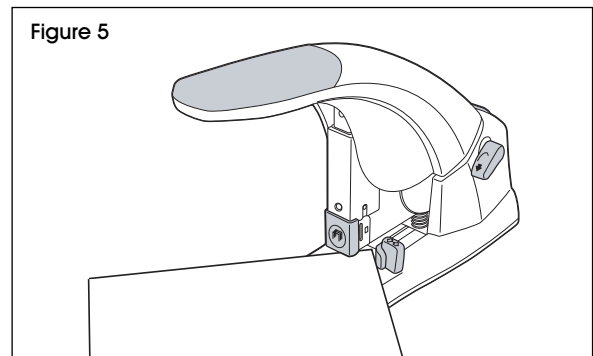

7. Push down completely on handle to staple. (See Figure 6)

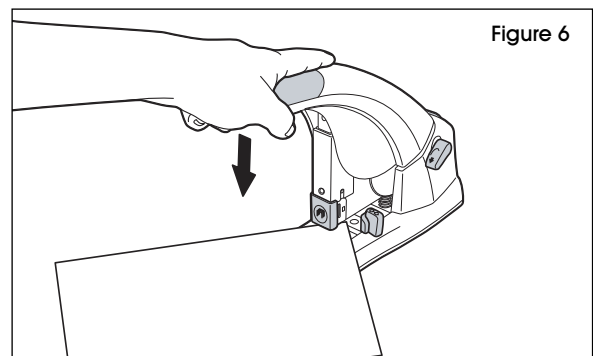

### TO REMOVE JAMMED STAPLES

1. Push down on jam release to release jammed staple. (See Figure 7)
2. If jammed staple has not been dislodged, push load button to release magazine and clear jammed staple. (See Figure 7)

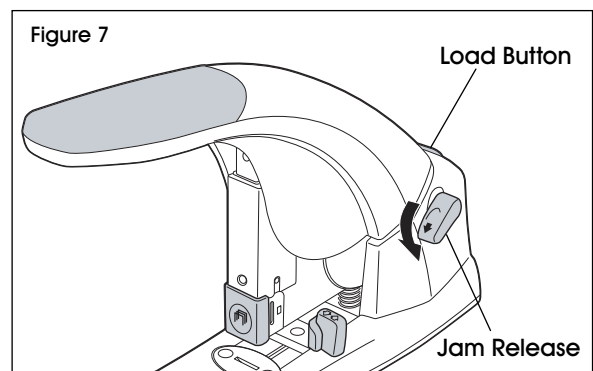

**ULINE**

1-800-295-5510  
uline.com

**ULINE** H-2323

800-295-5510

uline.mx

**SWINGLINE® LIGHT  
TOUCH™ ENGRAPADORA  
MANUAL DE ESCRITORIO  
DE USO PESADO**

**GRAPAS COMPATIBLES**



5/8"  
S-14967

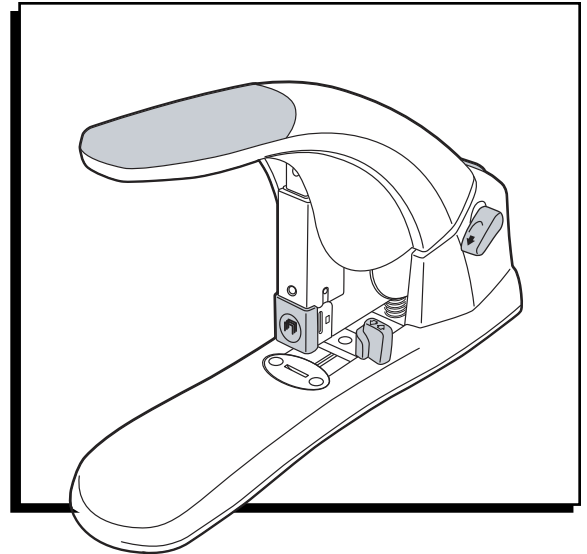

**FUNCIONAMIENTO**

1. Presione el botón de carga para liberar el cargador.  
(Vea Diagrama 1)

Diagrama 1

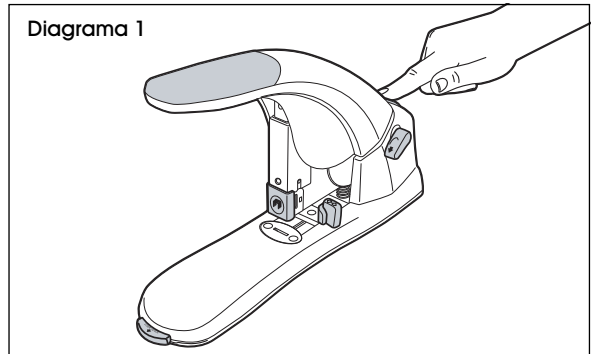

2. Jale el cargador completamente hacia afuera hasta que llegue al tope. (Vea Diagrama 2)

Diagrama 2

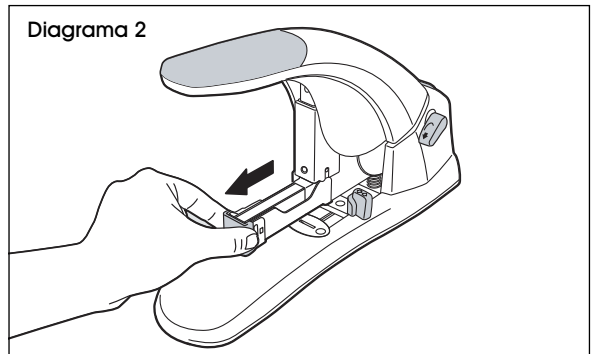

3. Inserte grapas para uso pesado de 5/8" (Modelo Uline S-14967). (Vea Diagrama 3)
4. Empuje el cargador para cerrarlo hasta que escuche un clic.

Diagrama 3

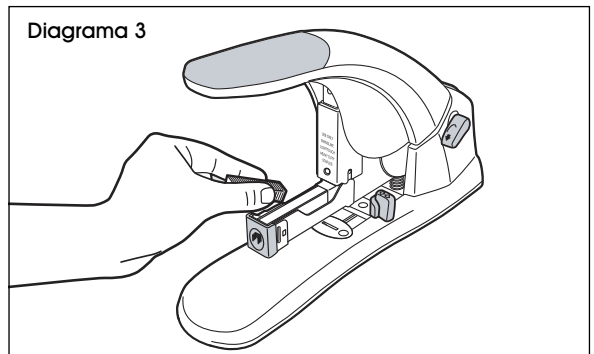

## CONTINUACIÓN DE FUNCIONAMIENTO

- Para ajustar la profundidad del papel, mueva las guías de profundidad hacia adelante para liberarlas. Ajuste la guía de profundidad de papel a la posición deseada y mueva las guías hacia atrás para trabar la guía de profundidad en su lugar. (Vea Diagrama 4)

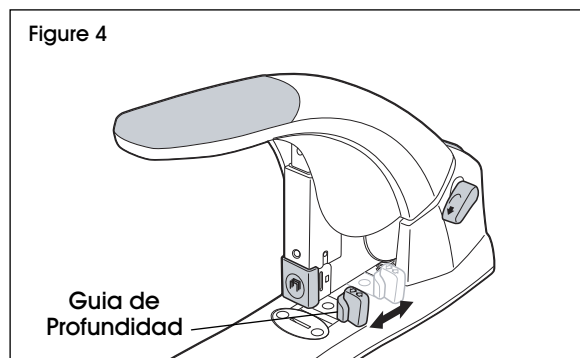

- Inserte el papel en la guía de profundidad de papel como se muestra para engrapar en ángulo. (Vea Diagrama 5)

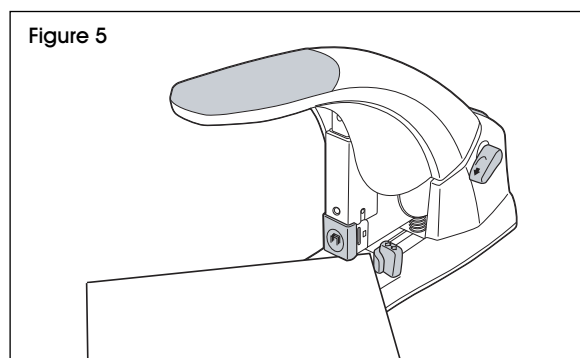

- Empuje el asa completamente hacia abajo para engrapar. (Vea Diagrama 6)

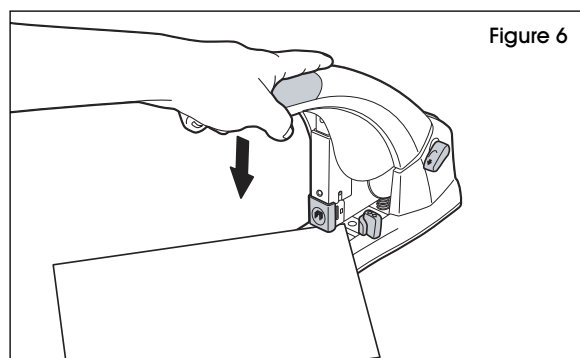

### PARA QUITAR LAS GRAPAS ATASCADAS

- Empuje el liberador de atascos para liberar la grapa atascada. (Vea Diagrama 7)
- Si la grapa atascada no se ha desatorado, presione el botón de carga para liberar el cargador y quitar la grapa atascada. (Vea Diagrama 7)

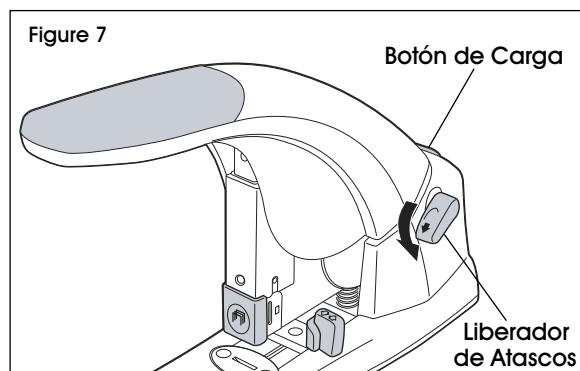

**ULINE**

800-295-5510  
uline.mx

**ULINE** H-2323

1-800-295-5510

uline.ca

**SWINGLINE<sup>MD</sup> LIGHT  
TOUCH<sup>MC</sup> – AGRAFEUSE  
MANUELLE DE TABLE  
ROBUSTE**

**AGRAFES COMPATIBLES**



1,6 cm (5/8 po)  
S-14967

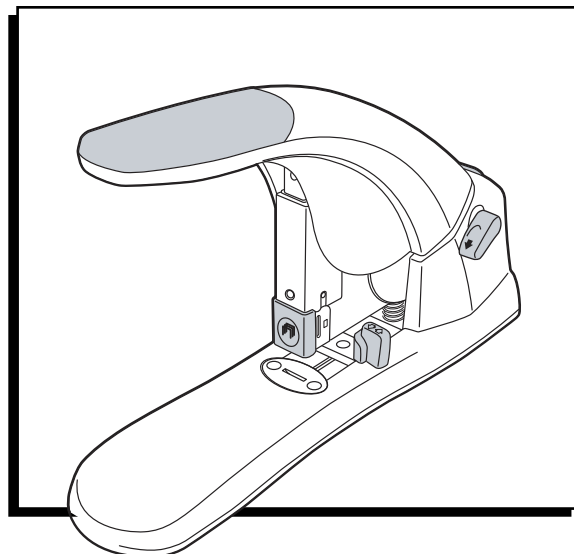

**FONCTIONNEMENT**

1. Appuyez sur le bouton de chargement pour libérer le magasin. (Voir Figure 1)
2. Tirez le magasin complètement jusqu'à ce qu'il s'arrête. (Voir Figure 2)
3. Chargez les agrafes robustes de 1,6 cm (5/8 po) (n° de modèle Uline S-14967) (Voir Figure 3)
4. Poussez pour fermer le magasin jusqu'à ce que vous entendiez un clic.

Figure 1

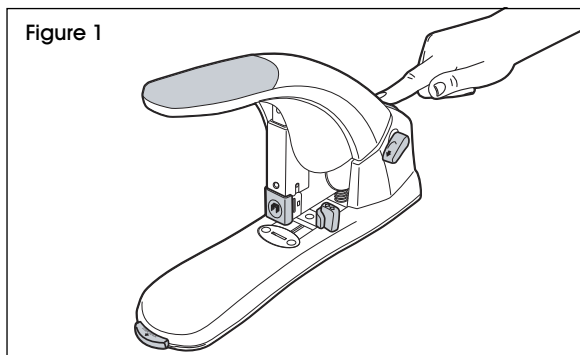

Figure 2

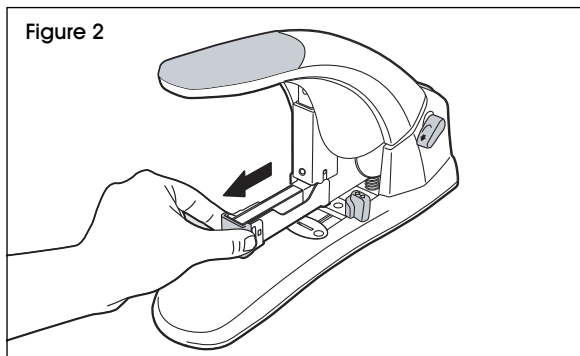
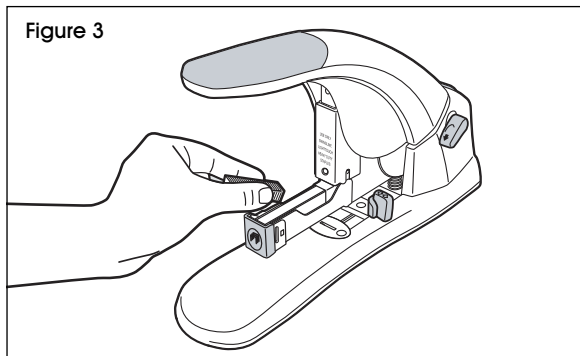
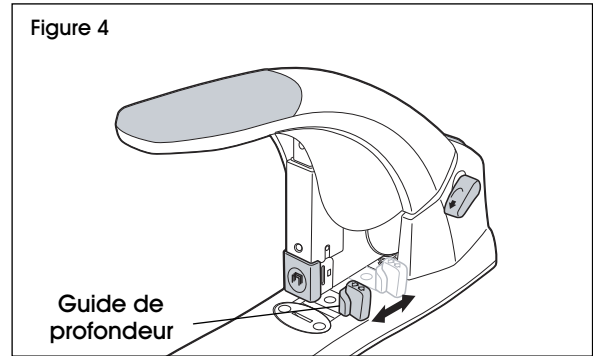

Figure 3



## FONCTIONNEMENT SUITE

5. Pour régler la profondeur de papier, déplacez le guide de profondeur vers l'avant pour déverrouiller. Réglez le guide de profondeur de papier à la position souhaitée et déplacez le guide vers l'arrière pour le verrouiller en place. (Voir Figure 4)



6. Insérez du papier dans le guide de profondeur de papier comme indiqué pour l'agrafage oblique. (Voir Figure 5)

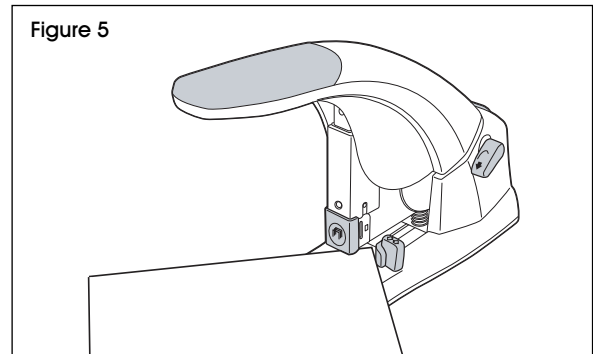

7. Poussez la poignée complètement vers le bas pouragrafer. (Voir Figure 6)

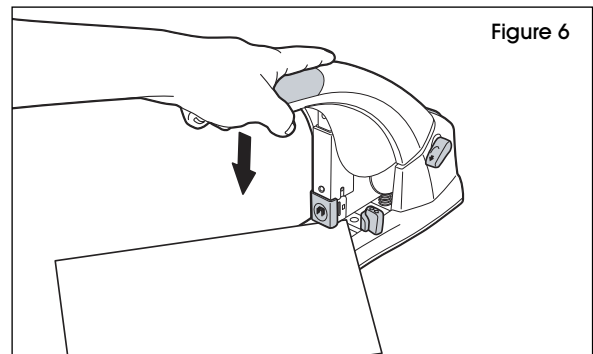

### POUR RETIRER DES AGRAFES COINCÉES

1. Poussez le bouton de délogement vers le bas pour libérer l'agrafe coincée. (Voir Figure 7)
2. Si l'agrafe coincée n'a pas été délogée, appuyez sur le bouton de chargement pour libérer le magasin et dégager l'agrafe coincée. (Voir Figure 7)

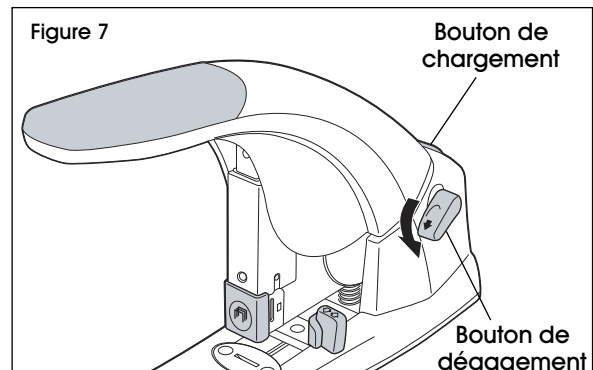

**ULINE**

1-800-295-5510  
uline.ca