

ULINE

CABINET DOLLY

1-800-295-5510
uline.com

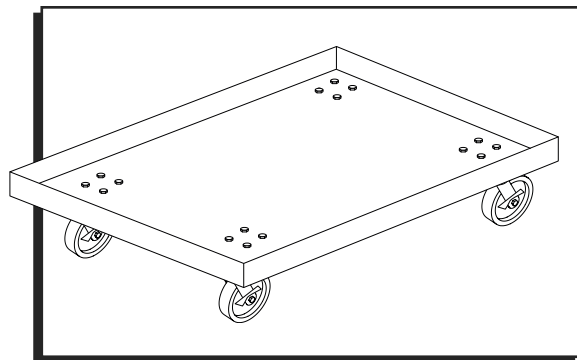

TOOL NEEDED

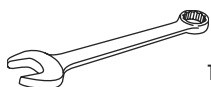

14 mm Wrench



NOTE: Weight capacity of the dolly is 1,000 lbs. This includes weight of storage cabinet.

PARTS



Caster with Brake x 4



Bolt x 16



Lock Washer x 16



Nut x 16

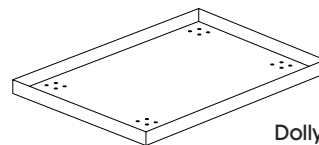

Dolly Tray x 1

ASSEMBLY

1. Align caster plate with bolt holes on dolly tray. Insert four bolts through dolly tray into caster plate. Attach bolts with lock washers and nuts. (See Figure 1)
2. Tighten nuts with a 14 mm wrench.
3. Repeat for remaining casters.



NOTE: Before setting storage cabinet on dolly please make sure all contents are removed from cabinet.



CAUTION! For file cabinets, use dolly for transport only. Do not open drawers while file cabinet is on dolly.

Figure 1

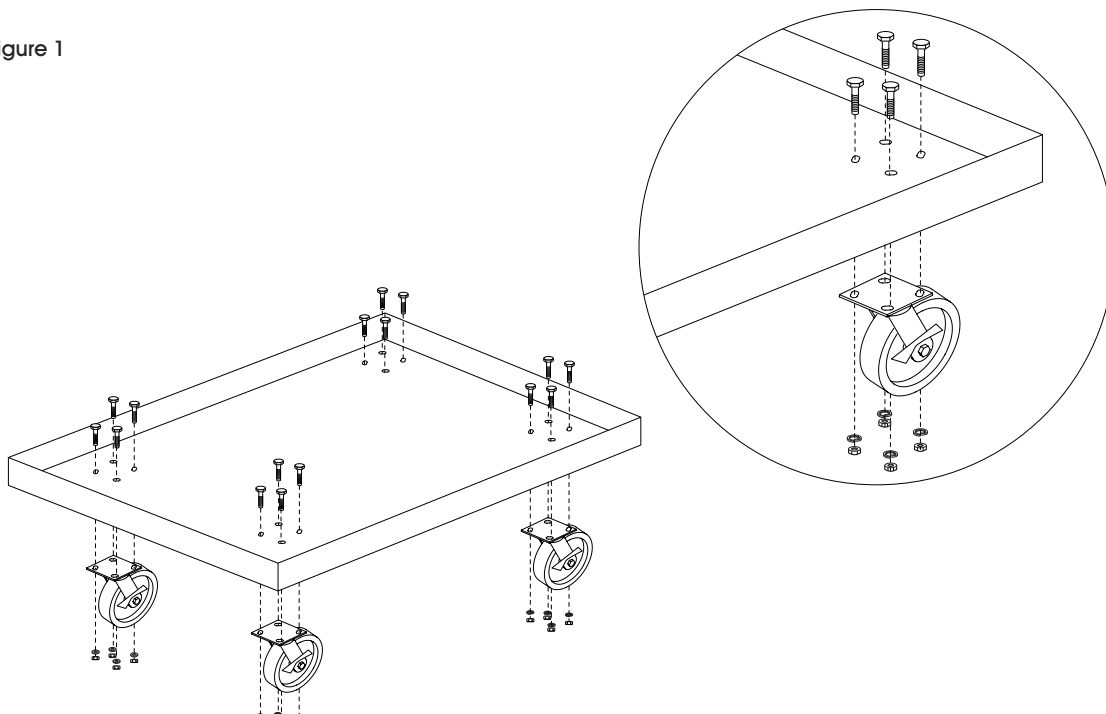

ULINE

PLATAFORMA CON RUEDAS PARA GABINETE

800-295-5510
uline.mx

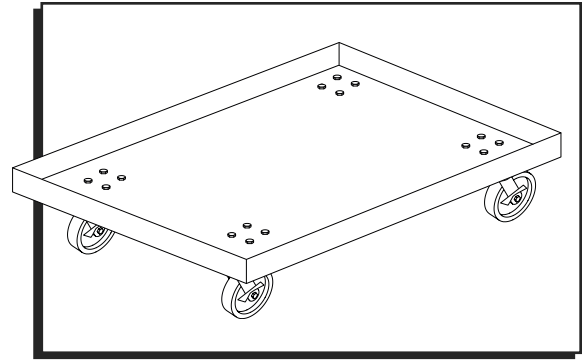

HERRAMIENTA NECESARIA



Llave de 14 mm



NOTA: La capacidad de peso de la plataforma con ruedas es de 453.6 kg (1,000 lbs). Esto incluye el peso del gabinete de almacenamiento.

PARTES

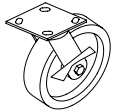

4 Ruedas con Freno



16 Pernos



16 Rondanas de Seguridad



16 Tuercas

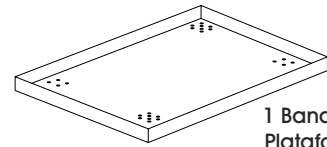

1 Bandeja para Plataforma con Ruedas

ENSAMBLE

1. Alinee la placa de la rueda con los orificios para pernos de la bandeja para plataforma con ruedas. Inserte cuatro pernos a través de la bandeja para plataforma con ruedas y de la placa de la rueda. Fije los pernos con rondanas de seguridad y tuercas. (Vea Diagrama 1)
2. Apriete las tuercas con una llave de 14 mm.
3. Repita con las ruedas restantes.



NOTA: Antes de colocar el gabinete de almacenamiento sobre la plataforma con ruedas, asegúrese de haber retirado todo el contenido del gabinete.



¡PRECAUCIÓN! Para archiveros, utilice la plataforma con ruedas solo para transportar. No abra los cajones mientras el archivero esté sobre la plataforma.

Diagrama 1

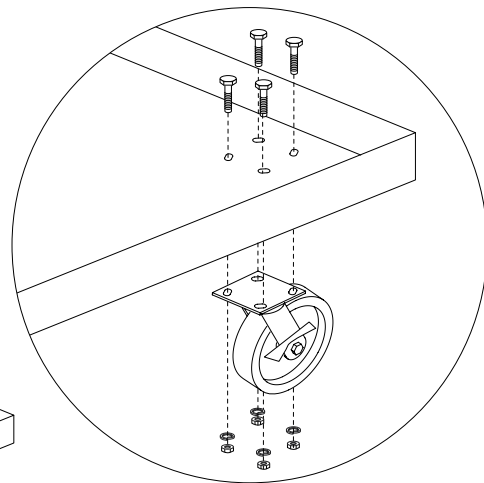
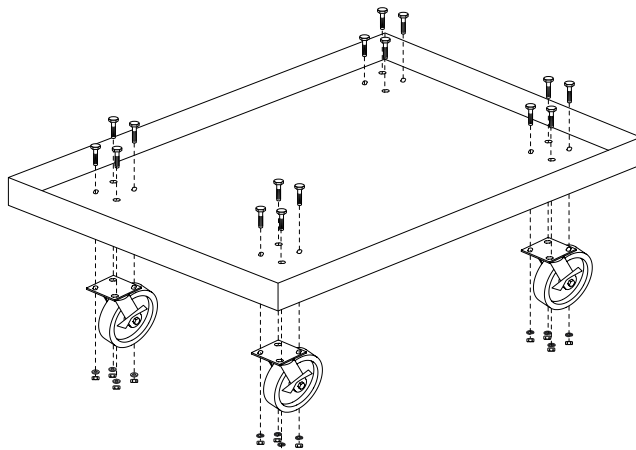

ULINE

SOCLE ROULANT POUR ARMOIRE DE RANGEMENT

1 800 295-5510

uline.ca

OUTIL REQUIS



Clé de 14 mm

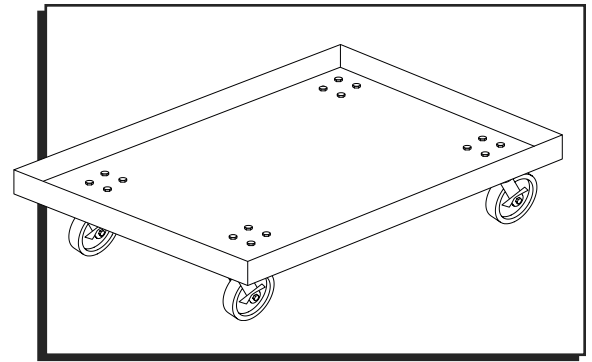

REMARQUE : Le chariot peut porter jusqu'à 453,6 kg (1 000 lb). Cela inclut le poids de l'armoire.

PIÈCES

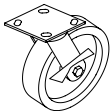

Roulette avec frein x 4



Boulon x 16

Rondelle de
blocage x 16

Écrou x 16

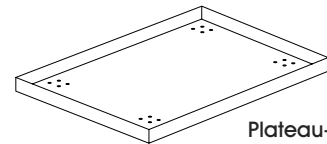

Plateau-chariot x 1

ASSEMBLAGE

1. Alignez la plaque de roulette avec les trous à boulon du plateau-chariot. Insérez quatre boulons dans la plaque de roulette en les enfilant à travers le plateau-chariot. Fixez les boulons avec des rondelles de blocage et des écrous. (Voir Figure 1)
2. Serrez les écrous avec une clé de 14 mm.
3. Répétez cette procédure pour les roulettes restantes.



REMARQUE : Veuillez vous assurer que tout le contenu de l'armoire a été retiré avant de l'installer sur le chariot.



MISE EN GARDE! Pour les classeurs, utilisez le socle uniquement pour le transport. N'ouvrez pas les tiroirs lorsque le classeur est sur le socle roulant.

Figure 1

