

TOOLS NEEDED

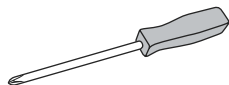

Phillips Head Screwdriver

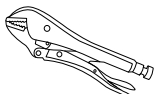

Locking Pliers

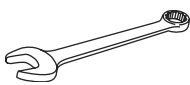

9/16" Wrench

ADJUSTABLE LEG PARTS



Adjustable Leg x 4



Screw x 4

ADJUSTABLE LEG ASSEMBLY

1. Place stool upside down on a flat surface.
2. Pull glide out of each stool leg.



NOTE: Use locking pliers if glides are difficult to remove.

3. Slide adjustable leg into stool leg and align mounting holes at preferred stool height.

4. Thread one screw through aligned mounting holes and tighten securely.
5. Repeat on remaining legs.



NOTE: Be sure to set all legs at the same height.

LEG ADJUSTMENTS

Leg Height – To adjust leg height, remove screw and slide leg to align mounting holes at new stool height. Thread screw through aligned mounting holes and tighten securely. Repeat on remaining legs.

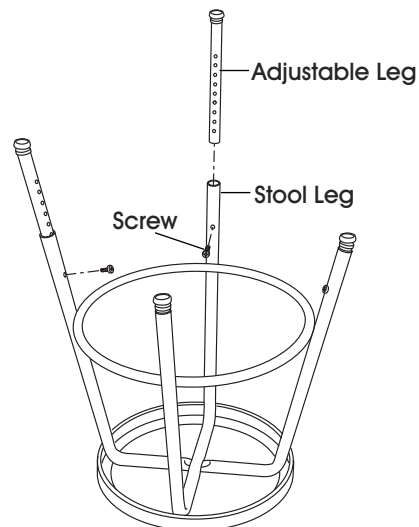

BACKREST PARTS

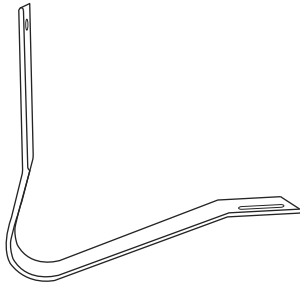

Mounting Post x 1

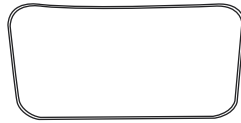

Backrest x 1

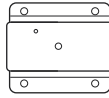

Mounting Plate x 1

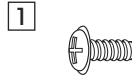

Mounting Screw x 4



Set Screw x 1

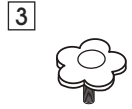

Plastic Knob x 1

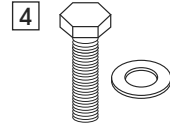

Bolt and Washer x 1

BACKREST ASSEMBLY

1. Place stool upside down on a flat surface. Align mounting plate with four holes closest to seat center where the legs cross. (See Figure 1)

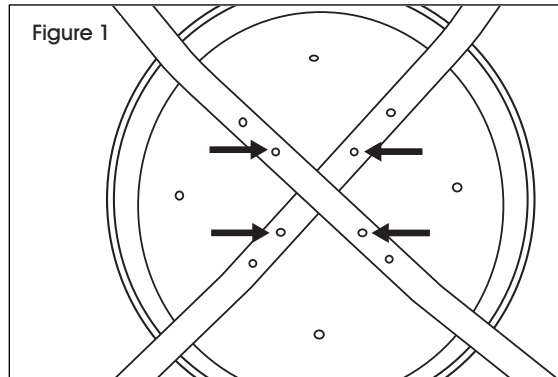

2. With flat side of mounting plate facing seat, use four mounting screws (1) to attach loosely, threading only halfway. Do not secure. (See Figure 2)

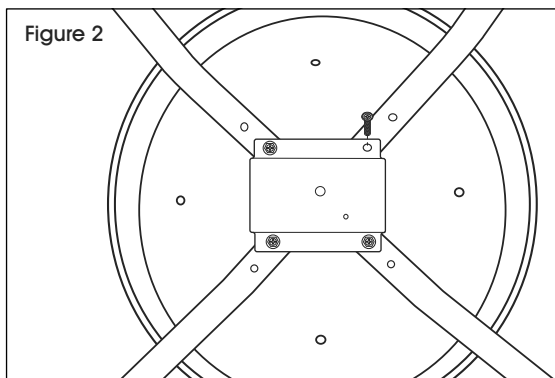

 **NOTE:** Screws may be difficult to thread initially. In this case, extra force may be necessary. Since screws are self-threading, they re-thread holes as necessary.

3. Slide mounting post in slot between seat and mounting plate. Indentation on post must align with offset hole in mounting plate. Use set screw (2) in offset hole to secure. (See Figure 3)

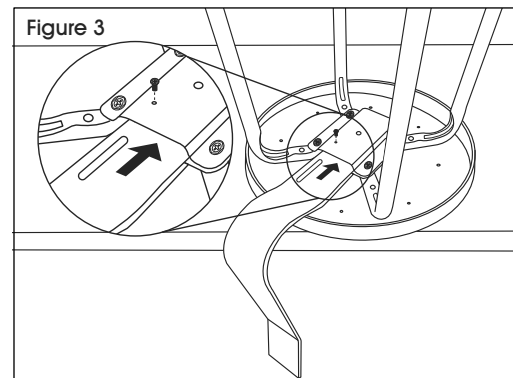

4. Fully tighten four mounting screws (1) installed in step 2.
5. Thread bolt and washer (4) into center hole in mounting plate. Set post at preferred seat depth and tighten bolt to secure. (See Figure 4)

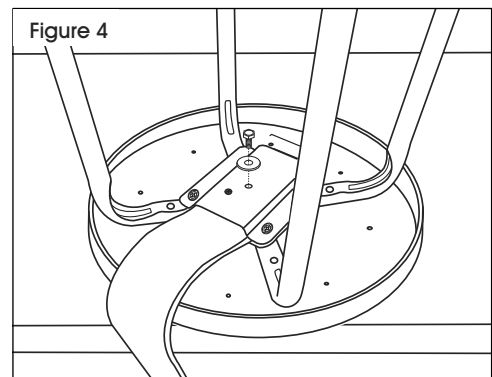

BACKREST ASSEMBLY CONTINUED

6. Turn stool upright. Slide backrest onto mounting post. The slot on backrest must align with hole at top of mounting post. Set backrest at preferred height and tighten plastic knob (3) through slot. (See Figure 5)



CAUTION! Ensure all screws are tightened securely before use. Check screws periodically – failure to keep all screws fastened securely may lead to injury.

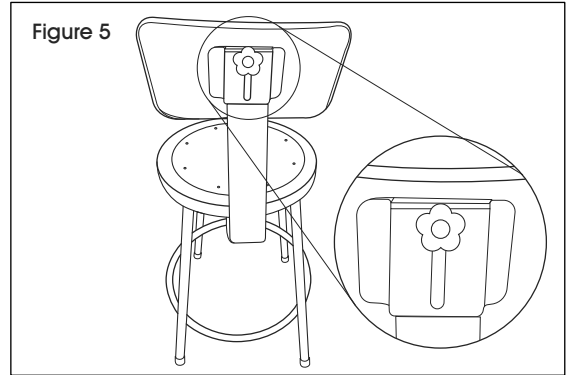

BACKREST ADJUSTMENTS

1. Backrest Height – To adjust backrest height, loosen bolt and slide backrest up or down. Set backrest at preferred height and tighten bolt to secure.
2. Seat Depth – To adjust seat depth, loosen bolt and slide the backrest in or out. Set backrest at preferred seat depth and tighten bolt to secure.

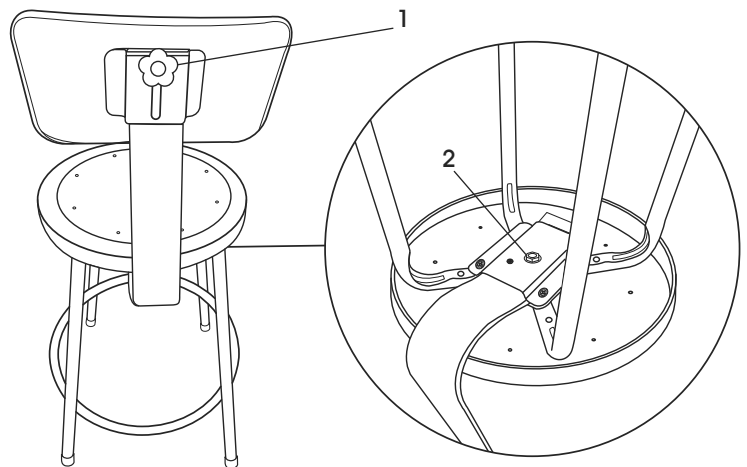

ULINE

1-800-295-5510
uline.com

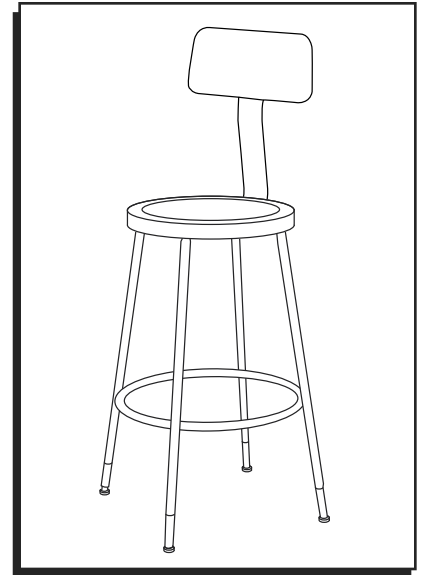
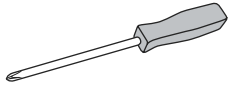
**HERRAMIENTAS NECESARIAS**

Desarmador de Cruz

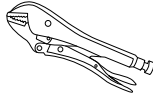

Pinzas de Presión

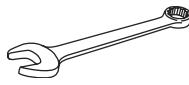

Llave de 9/16"

PARTES DE LAS PATAS AJUSTABLES

4 Patas Ajustables



4 Tornillos

ENSAMBLE DE PATAS AJUSTABLES

1. Voltee el banco hacia abajo en una superficie plana.
2. Saque el nivelador de cada una de las patas.

 **NOTA:** Utilice las pinzas de presión si se dificulta sacarlas.

3. Deslice la pata ajustable en la pata del banco y alinee los orificios de instalación a la altura deseada.

4. Enrosque un tornillo a través de los orificios alineados y apriete para asegurarlo.
5. Repita la operación en las patas restantes.

 **NOTA:** Asegúrese de colocar todas las patas a la misma altura.

AJUSTES DE LAS PATAS

Altura de las Patas – Para ajustar la altura, retire el tornillo y deslice la pata para alinear los orificios de instalación a la nueva altura del banco. Enrosque un tornillo a través de los orificios alineados y apriete para asegurarlo. Repita la operación en las patas restantes.

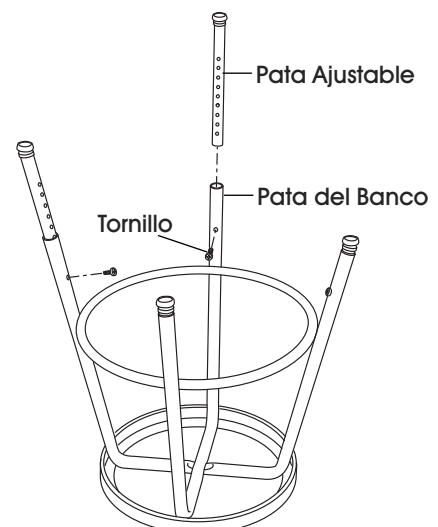

PARTES DEL RESPALDO

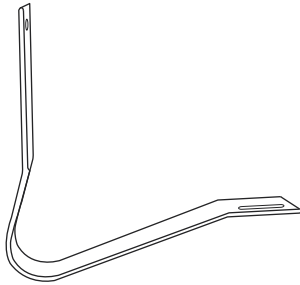

1 Poste de Instalación

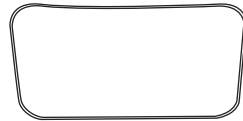

1 Respaldo

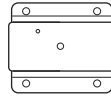

1 Placa de Instalación

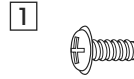

4 Tornillos de Instalación

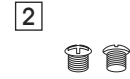

1 Tornillo de Ajuste

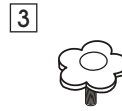

1 Perilla de Plástico

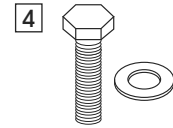

1 Perno y Rondana

ENSAMBLE DEL RESPALDO

1. Voltee el banco hacia abajo en una superficie plana. Alinee la placa de instalación con los cuatro orificios más cercanos al centro del asiento donde se cruzan las patas. (Vea Diagrama 1)

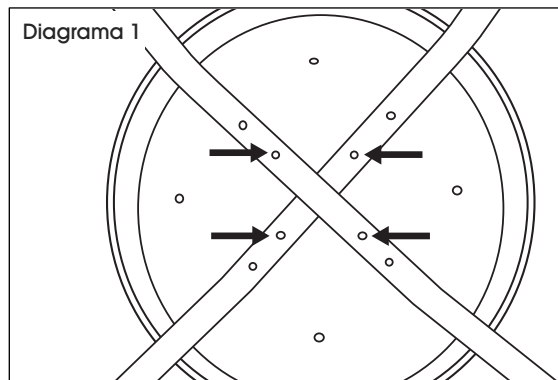

2. Con el lado plano de la placa de instalación volteando hacia el asiento, utilice cuatro tornillos de instalación (1) para fijarla sin apretar, atornille solo la mitad. No lo asegure. (Vea Diagrama 2)

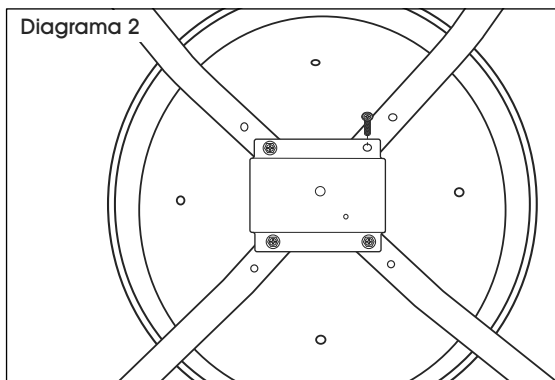

- NOTA:** De inicio, puede ser difícil enroskar los tornillos. En ese caso, puede ser necesario aplicar mayor fuerza. Como los tornillos son autorroscantes, forman la rosca del orificio al tamaño que sea necesario.

3. Deslice el poste de instalación en la ranura entre el asiento y la placa de instalación. La muesca del poste se debe alinear al orificio inclinado de la placa de instalación. Utilice el tornillo de ajuste (2) en el orificio inclinado para asegurarlo. (Vea Diagrama 3)

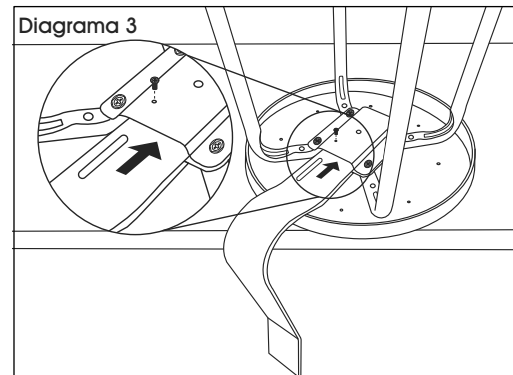

4. Apriete por completo los cuatro tornillos de instalación (1) del paso 2.
5. Enrosque perno y rondana (4) en el orificio central de la placa de instalación. Coloque el poste en el asiento a la profundidad deseada y apriete la perilla para asegurar. (Vea Diagrama 4)

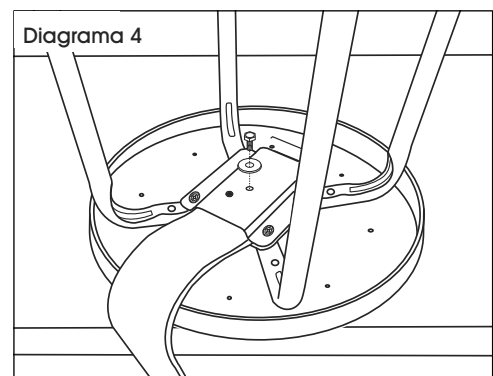

CONTINUACIÓN DEL ENSAMBLE DEL RESPALDO

6. Gire el banco de manera vertical. Deslice el respaldo en el poste de instalación. La ranura del respaldo debe alinearse con el orificio en la parte superior del poste de instalación. Coloque el respaldo a la altura deseada y asegure perilla de plástico (3) a través de la ranura y el poste. (Vea Diagrama 5)



¡PRECAUCIÓN! Antes de usarlo asegúrese de que todos los tornillos estén apretados de manera segura. Revise los tornillos periódicamente, no mantenerlos apretados puede ocasionar lesiones.



Diagrama 5

AJUSTES DEL RESPALDO

1. Altura del Respaldo – Para ajustar la altura del respaldo, afloje la perilla de plástico y deslice el respaldo hacia arriba o abajo. Coloque el respaldo a la altura deseada y apriete el perilla de plástico para asegurarlo.
2. Profundidad del Asiento – Para ajustar la profundidad del asiento, afloje la perno y deslice el respaldo hacia adentro o afuera. Coloque el respaldo a la profundidad deseada y apriete la perno para asegurarlo.

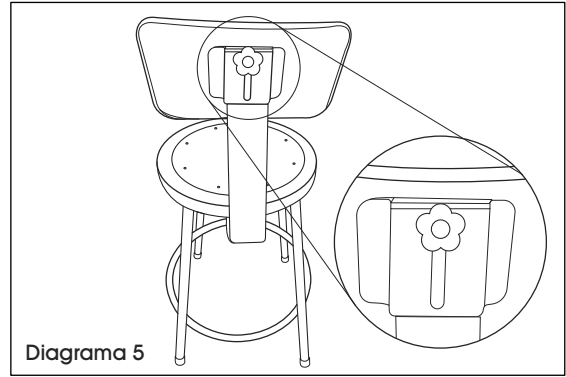
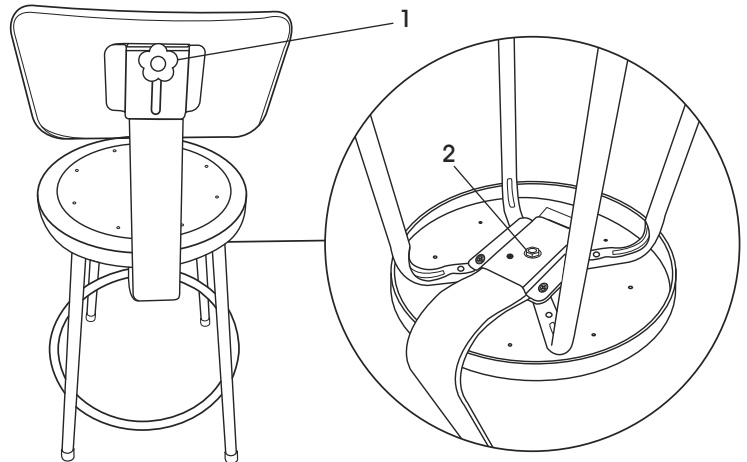

ULINE

800-295-5510

uline.mx

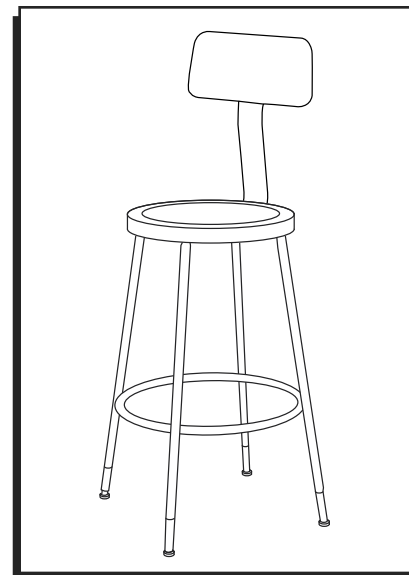
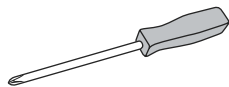
**OUTILS REQUIS**

Tournevis cruciforme

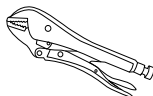

Pince-étau

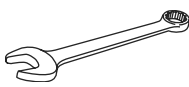

Clé de 9/16 po

PIÈCES DES PIEDS AJUSTABLES

Pied ajustable x 4



Vis x 4

MONTAGE DES PIEDS AJUSTABLES

1. Posez le tabouret à l'envers sur une surface plane.
2. Enlevez les patins des pieds.



REMARQUE : Utilisez la pince-étau si les patins sont difficiles à retirer.

3. Faites glisser le pied ajustable dans le pied du tabouret et alignez les trous en fonction de la hauteur choisie.

4. Insérez une vis dans les trous alignés et vissez fermement.

5. Répétez l'opération pour les autres pieds.



REMARQUE : Veillez à ajuster tous les pieds à la même hauteur.

AJUSTEMENT DES PIEDS

Hauteur des pieds – Pour ajuster la hauteur, enlevez la vis et faites glisser le pied pour aligner les trous à une nouvelle hauteur. Insérez la vis dans les trous alignés et vissez fermement. Répétez l'opération pour les autres pieds.

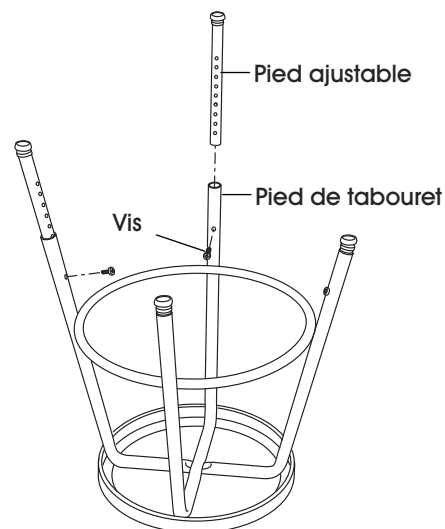

PIÈCES DU DOSSIER

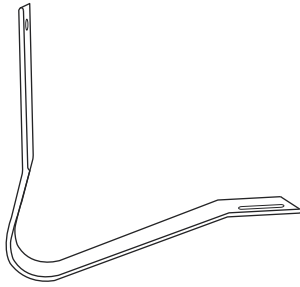

Montant x 1

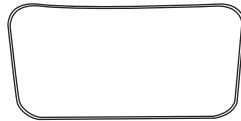

Dossier x 1

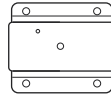

Plaque de montage x 1

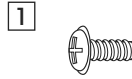

Vis de montage x 4



Vis de réglage x 1

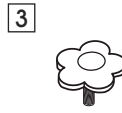

Bouton en plastique x 1

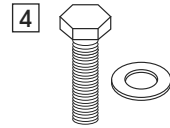

Boulon et rondelle x 1

MONTAGE DU DOSSIER

1. Posez le tabouret à l'envers sur une surface plane. Alignez la plaque de montage sur les quatre trous les plus proches du centre du siège au niveau de l'intersection des pieds. (Voir Figure 1)

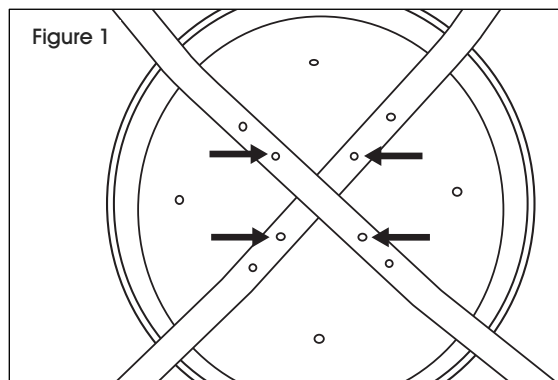

2. Avec la face plate de la plaque de montage tournée vers le siège, insérez quatre vis de montage (1) à moitié et sans serrer. Ne les fixez pas. (Voir Figure 2)

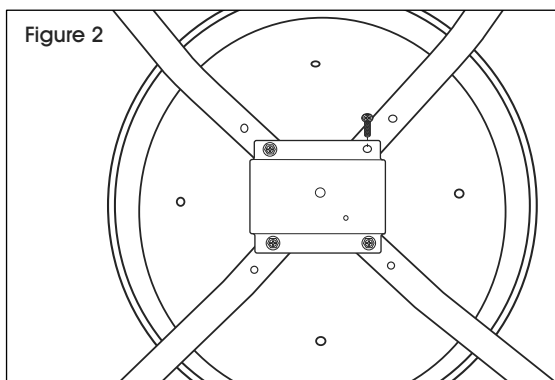

- REMARQUE :** Il se peut qu'il soit difficile au début de visser les vis. Il sera donc nécessaire d'user de la force. Les trous sont filetés d'après les vis puisque celles-ci sont autotaraudeuses.

3. Insérez le montant dans la fente située entre le siège et la plaque de montage. Le creux sur le montant doit s'aligner avec le trou décalé de la plaque de montage. Fixez le tout en insérant une vis de réglage (2) par le trou décalé. (Voir Figure 3)

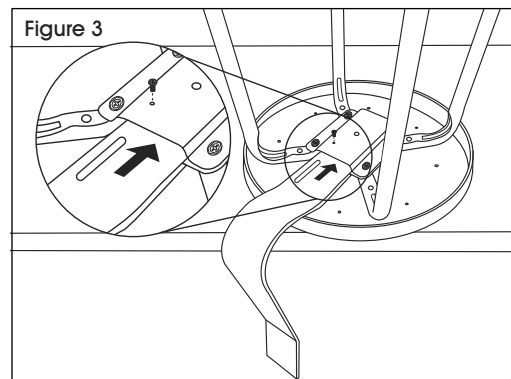

4. Serrez complètement les quatre vis de montage (1) qui ont été installées à l'étape 2.
5. Insérez le boulon et rondelle (4) dans le trou au centre de la plaque de montage. Réglez le montant à la profondeur d'assise désirée et serrez le bouton en plastique pour le fixer. (Voir Figure 4)

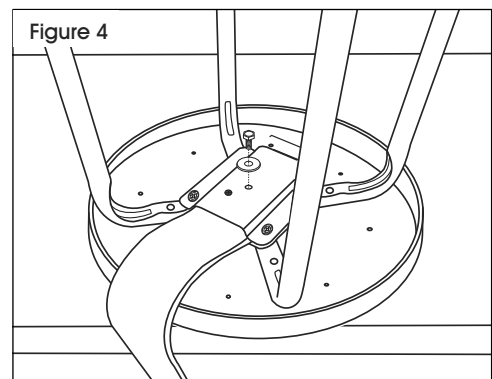

MONTAGE DU DOSSIER (SUITE)

- Placez le tabouret à l'endroit. Faites glisser le dossier sur le montant. La fente sur le dossier doit s'aligner sur le trou situé en haut du montant. Réglez le montant à la hauteur désirée et fixez un bouton en plastique (3) dans le montant à travers la fente pour le fixer. (Voir Figure 5)



MISE EN GARDE! Assurez-vous que toutes les vis sont bien serrées avant l'utilisation. Vérifiez les vis régulièrement – Le fait de ne pas maintenir les vis bien serrées pourraient entraîner des blessures.

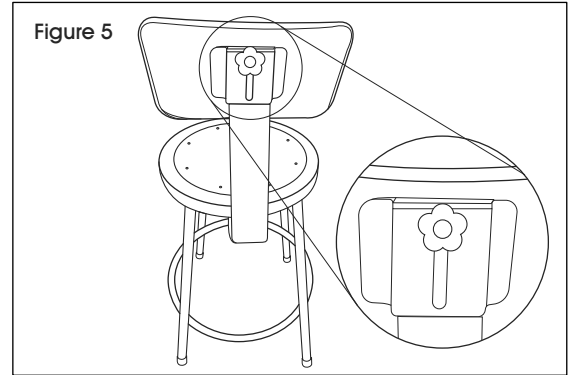

AJUSTEMENTS DU DOSSIER

- Hauteur du dossier – Pour ajuster la hauteur du dossier, desserrez le bouton en plastique et faites glisser le dossier vers le haut ou le bas. Réglez le dossier à la hauteur désirée et serrez le bouton en plastique on pour le fixer.
- Profondeur d'assise – Pour régler la profondeur d'assise, desserrez le boulon et faites glisser le siège vers l'intérieur ou l'extérieur. Réglez le dossier à la profondeur d'assise désirée et serrez le boulon pour le fixer.

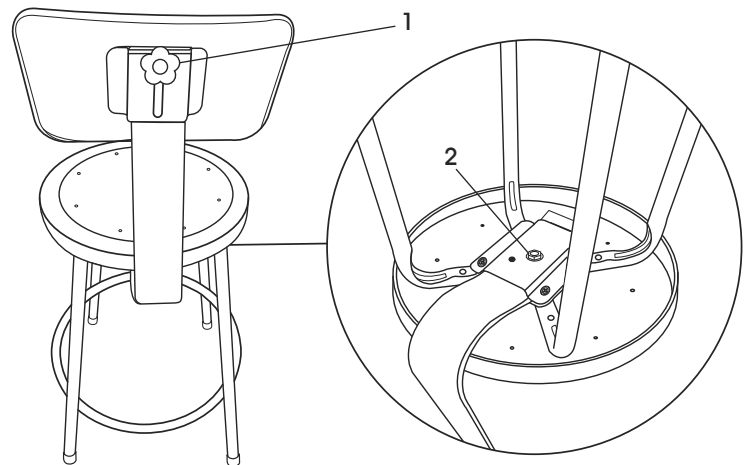

ULINE

1-800-295-5510
uline.ca