

ULINE H-2523 FOLDING CHAIR DOLLY – 35 CHAIR CAPACITY

1-800-295-5510
uline.com

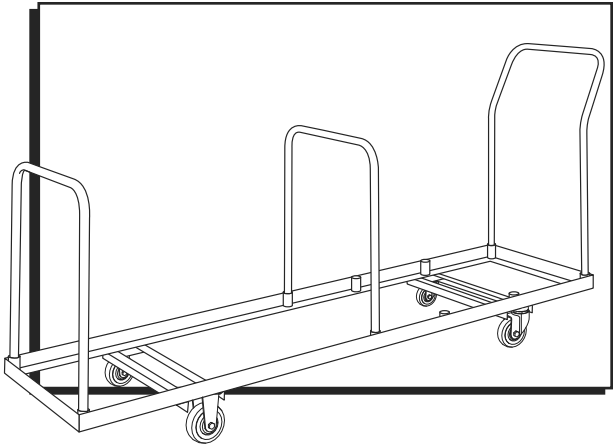

PARTS

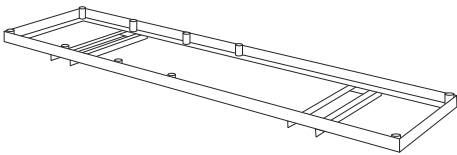

Dolly Frame x 1

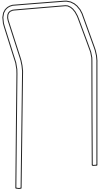

Curved Handle x 1

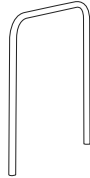

Straight Handle x 2



Rigid Caster x 2



Swivel Caster x 2



M8 x 16 mm Allen Key Bolt x 16

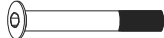

M6 x 40 mm Allen Key Bolt x 2

ASSEMBLY

1. Using eight M8 x 16 mm bolts, attach swivel casters on end of dolly frame with multiple sockets. (See Figure 1)

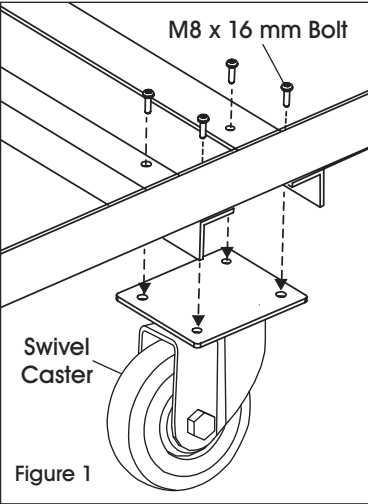

2. Attach rigid casters to the other end of the frame using eight M8 x 16 mm bolts.

3. Insert curved handle into sockets at end of dolly frame that has swivel casters. Attach using two M6 x 40 mm bolts. (See Figure 2)

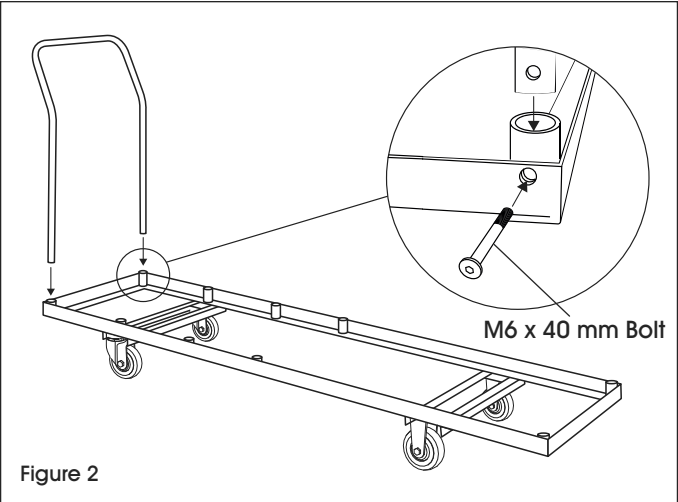

ASSEMBLY CONTINUED

4. Insert one straight handle into the sockets at the other end of the unit. (See Figure 3)
5. Load desired amount of chairs onto dolly and place second straight handle into sockets that best fit the number of chairs. (See Figure 3)

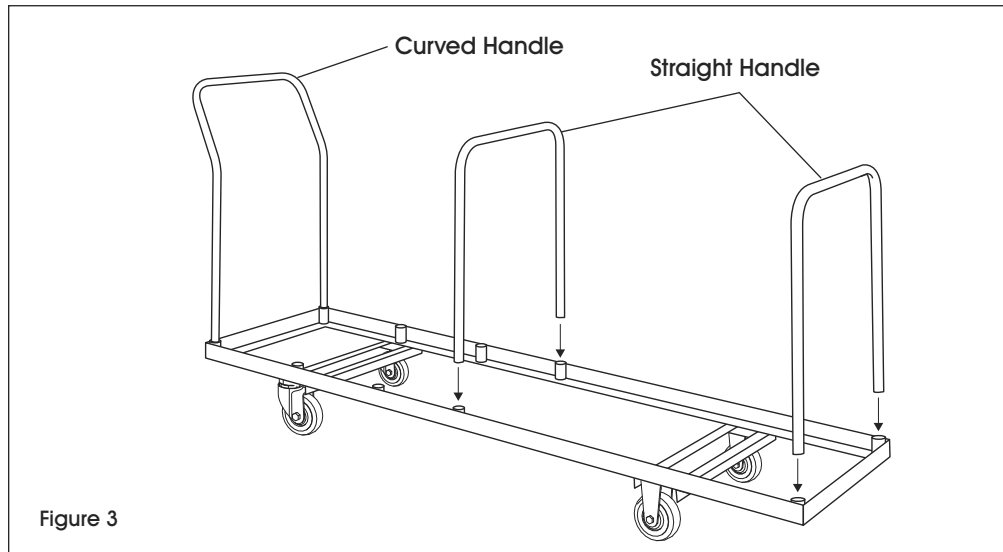

STACKING CHAIRS

The center straight handle adjusts based on the number of chairs stacked on the dolly:

- If fewer than 18 chairs are stacked, start stacking chairs on the left end of the dolly. (See Figure 4)
- If more than 18 chairs are stacked, start stacking chairs on right. (See Figure 5)

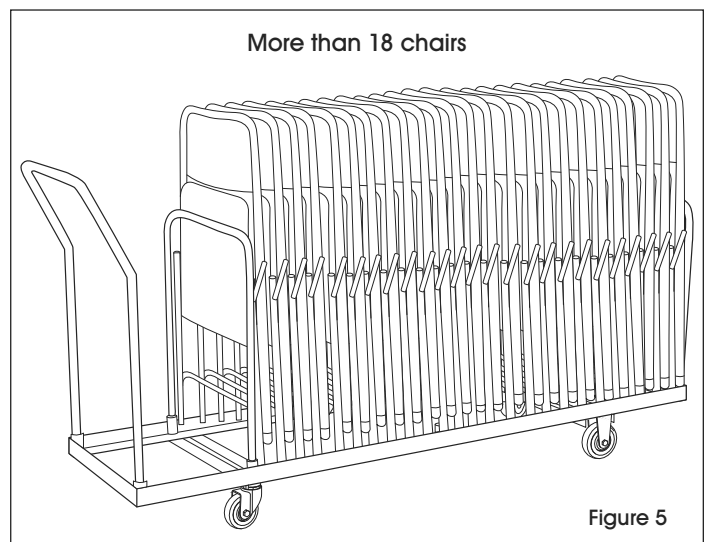
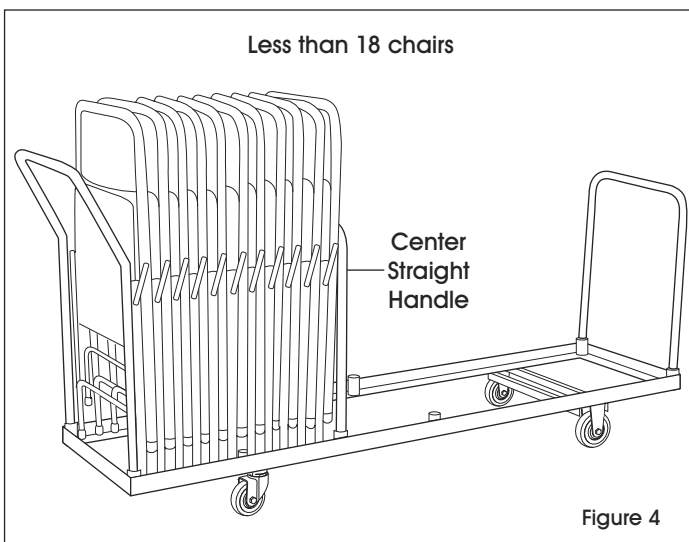

ULINE

1-800-295-5510
uline.com

ULINE H-2523

**CARRITO PARA
SILLAS PLEGABLES –
CAPACIDAD PARA
35 SILLAS**

800-295-5510
uline.mx

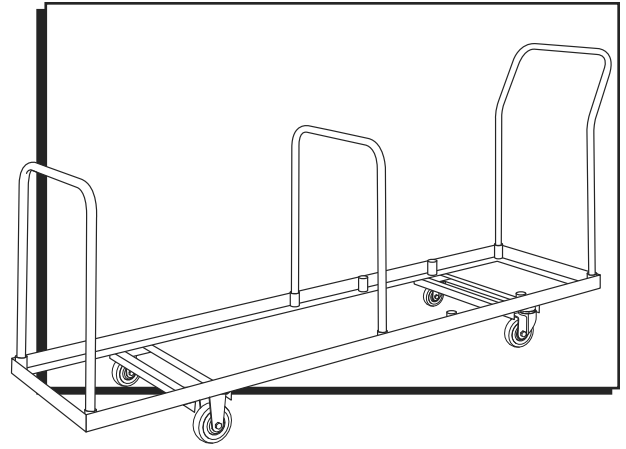

PARTES

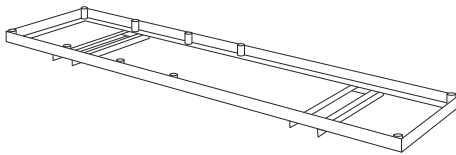

1 Armazón del Carrito

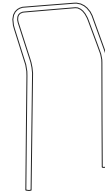

1 Asa Curva

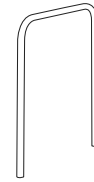

2 Asas Rectas



2 Ruedas Rígidas



2 Ruedas Giratorias



16 Pernos Cabeza Allen M8 x 16 mm



2 Pernos Cabeza Allen M6 x 40 mm

ENSAMBLE

1. Coloque las ruedas giratorias en el extremo del armazón del carrito con varios conectores y utilizando ocho pernos M8 x 16 mm. (Vea Diagrama 1)

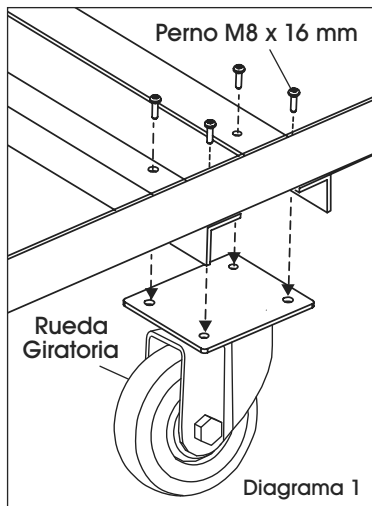

2. Coloque las ruedas rígidas en el otro extremo del armazón con ocho pernos M8 x 16 mm.

3. Inserte el asa curva en los conectores en el extremo del armazón de la plataforma que cuenta con ruedas giratorias. Fije utilizando dos pernos M6 x 40 mm. (Vea Diagrama 2)

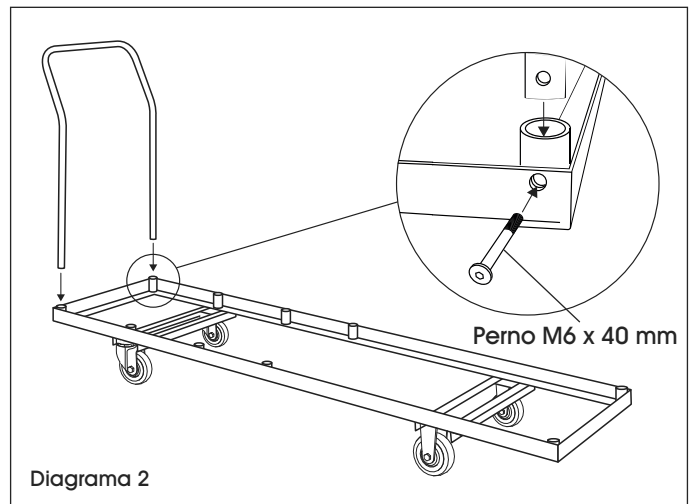

CONTINUACIÓN DE ENSAMBLE

4. Inserte el asa recta en los conectores y en el otro extremo de la unidad. (Vea Diagrama 3)
5. Cargue la cantidad de sillas en la plataforma y coloque la segunda asa recta en los conectores adecuados según el número de sillas. (Vea Diagrama 3)

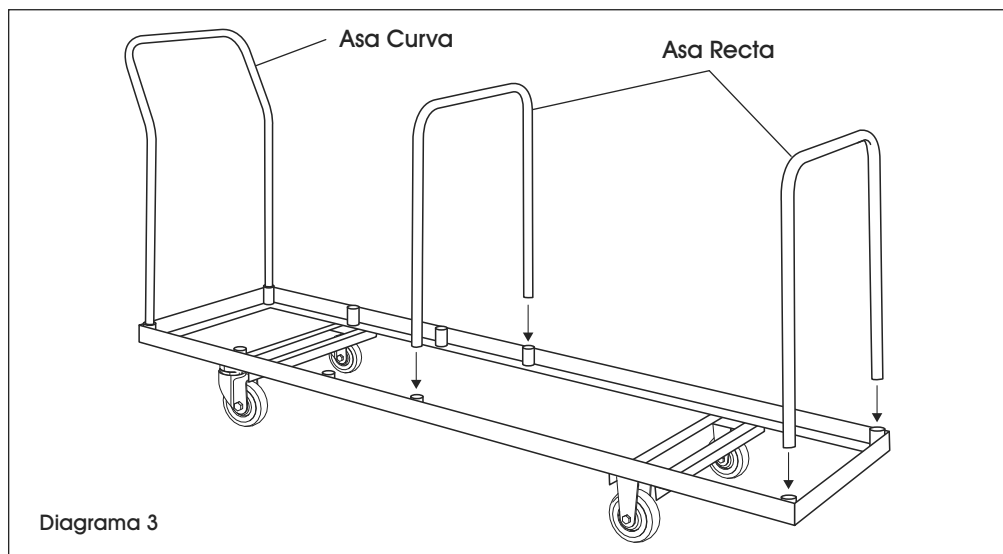

ESTIBAR SILLAS

Se ajusta el asa central recta basado en la cantidad de sillas estibadas en la plataforma con ruedas:

- Si se estiban menos de 18 sillas, empiece a estibarlas desde el extremo izquierdo de la plataforma. (Vea Diagrama 4)
- Si se estiban más de 18 sillas, empiece a estibarlas desde la derecha. (Vea Diagrama 5)

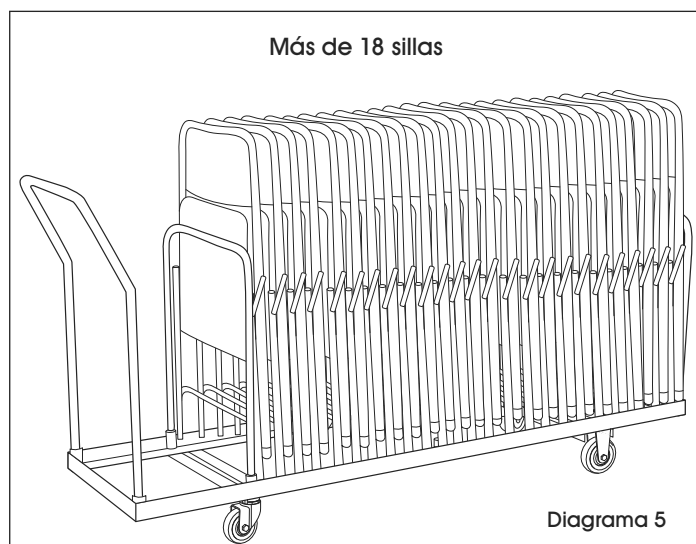
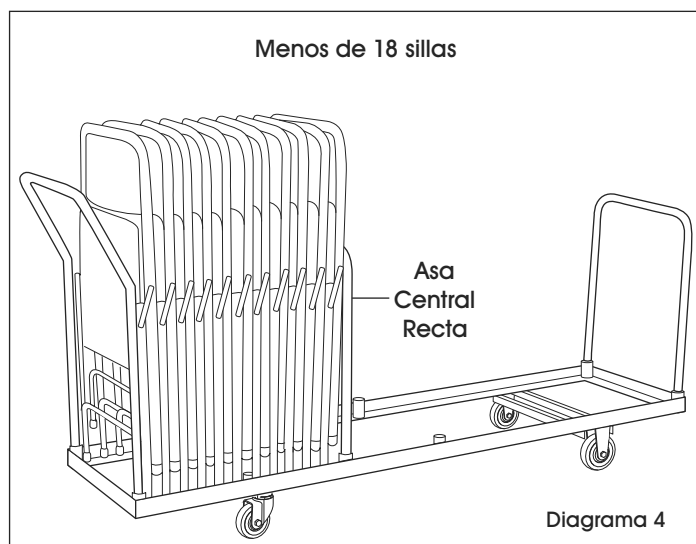

ULINE

800-295-5510
uline.mx

ULINE H-2523

**SOCLE ROULANT POUR
CHAISES PLIANTES –
CAPACITÉ DE
35 CHAISES**

1 800 295-5510
uline.ca

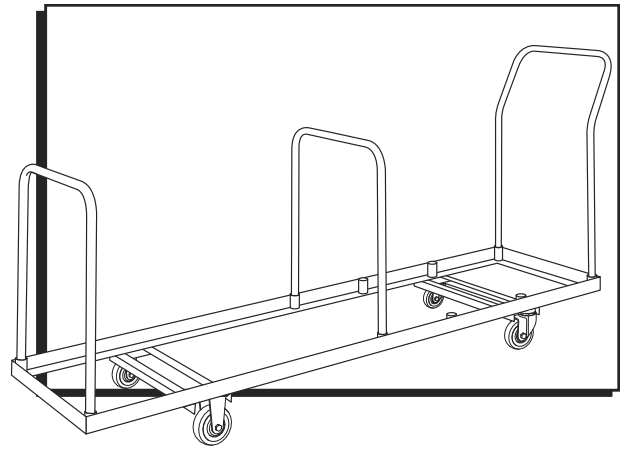

PIÈCES

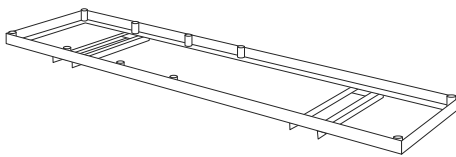

Cadre de socle roulant x 1



Poignée courbée x 1

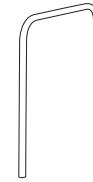

Poignée droite x 2



Roulette fixe x 2



Roulette pivotante x 2



Boulon à clé Allen M8 x 16 mm x 16



Boulon à clé Allen M6 x 40 mm x 2

ASSEMBLAGE

1. Fixez les roulettes pivotantes à l'extrémité du cadre de socle roulant comportant plusieurs emboîtures à l'aide de huit boulons M8 x 16 mm. (Voir Figure 1)

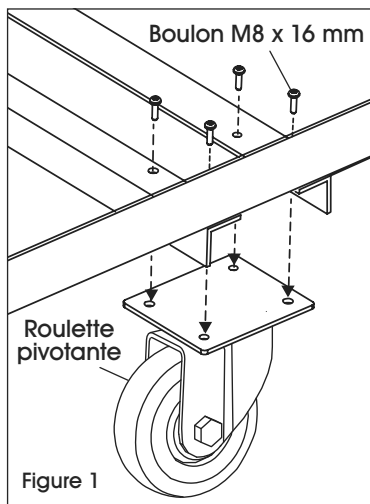

3. Insérez la poignée courbée dans les emboîtures situées à l'extrémité du cadre de socle roulant où se trouvent les roulettes pivotantes. Fixez-la avec deux boulons M6 x 40 mm. (Voir Figure 2)

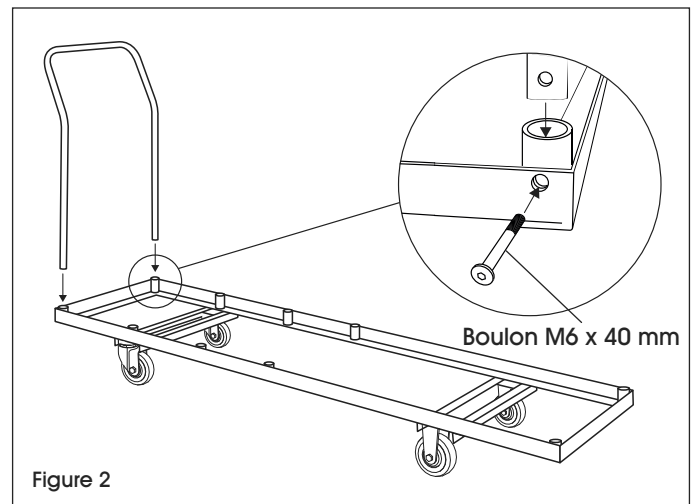

2. Fixez les roulettes fixes à l'autre extrémité du cadre de socle roulant à l'aide de huit boulons M8 x 16 mm.

MONTAGE SUITE

4. Insérez une poignée droite dans les emboîtures de l'autre extrémité du cadre de socle roulant. (Voir Figure 3)
5. Empilez la quantité désirée de chaises sur le socle roulant et placez la deuxième poignée droite dans les emboîtures correspondant le mieux au nombre de chaises à empiler. (Voir Figure 3)

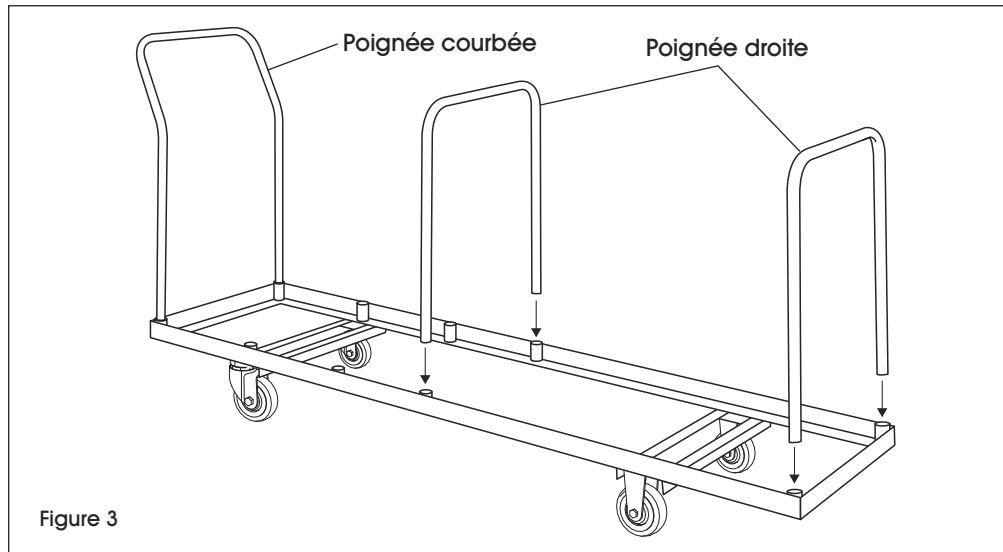

EMPILEMENT DES CHAISES

La poignée droite centrale est ajustable en fonction du nombre de chaises à empiler sur le socle roulant :

- Lorsque vous avez moins de 18 chaises à ranger, commencez à les empiler sur le côté gauche du socle roulant. (Voir Figure 4)
- Lorsque vous avez plus de 18 chaises à ranger, commencez à les empiler sur le côté droit du socle roulant. (Voir Figure 5)

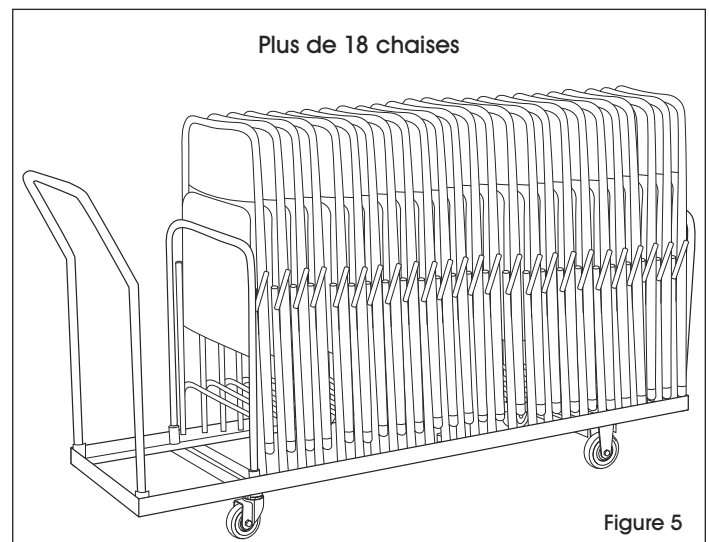
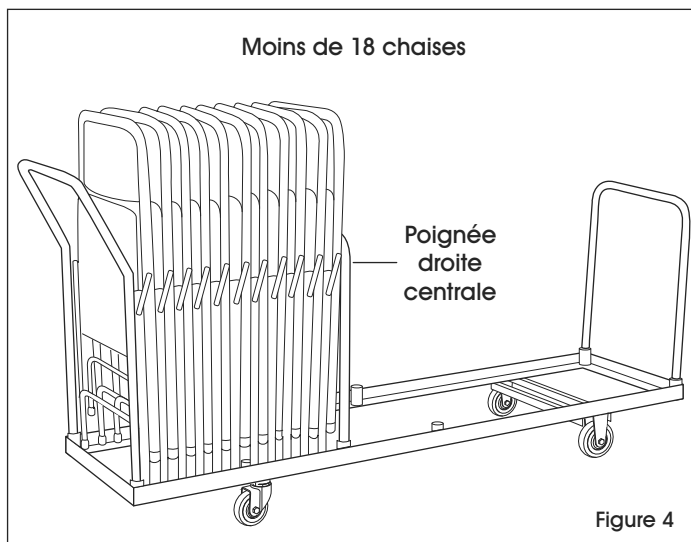

ULINE

1 800 295-5510
uline.ca