

ULINE H-2557 GOJO® FOAMING SOAP PUSH DISPENSER

1-800-295-5510
uline.com

TOOLS NEEDED

For optional hardware installation (not included):



Electric Drill



1/4" Drill Bit

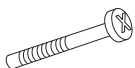

Type A #10 x 1" Screw x 4



#10 x 1" Anchor x 4

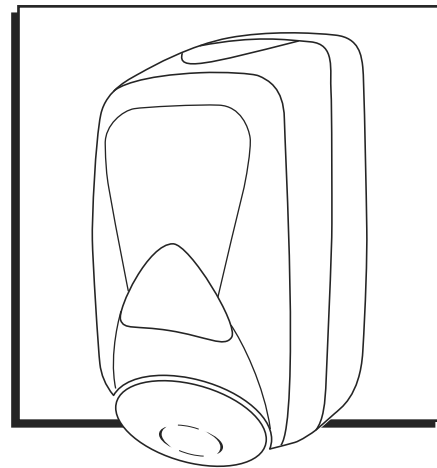

INSTALLATION

ADHESIVE TAPE INSTALLATION

 **NOTE:** Use only on smooth, dry surfaces.

1. Clean installation surface with an alcohol prep pad (not included). Allow surface to dry for 60 seconds.
2. Install the dispenser at least 10" above countertop. (See Figure 1)

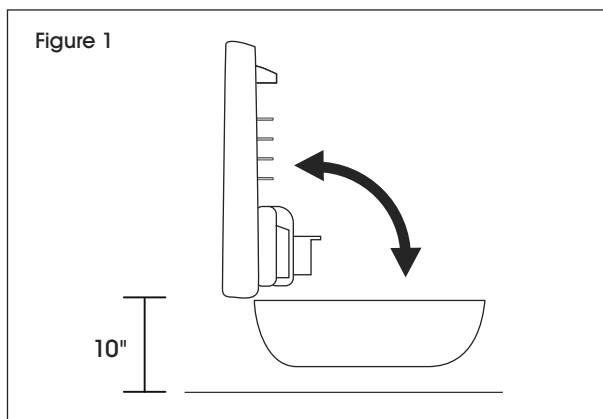

3. Peel paper backing off of adhesive tape and press dispenser firmly into position. (See Figure 2)

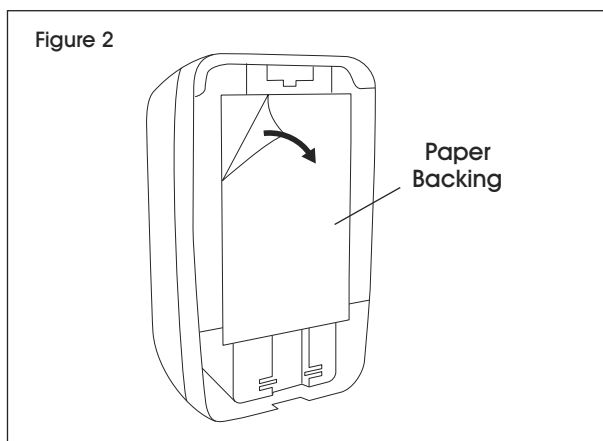

4. Open dispenser by inserting key into key access hole and push up until front cover opens. (See Figure 3)

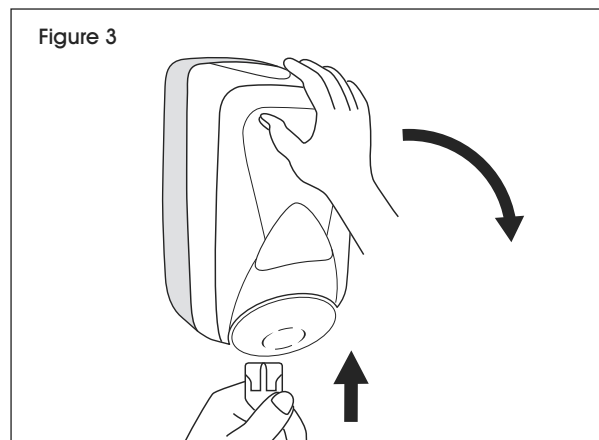

5. Press firmly on back plate for 30 seconds. For maximum adhesion, do not load refill for 24 hours. (See Figure 4)

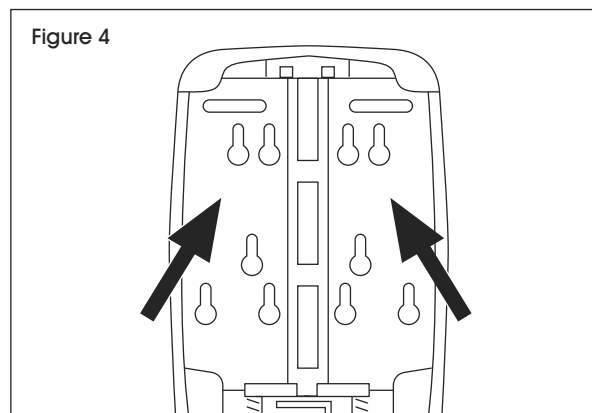

INSTALLATION CONTINUED

HARDWARE INSTALLATION

 **NOTE:** Use on rough or smooth surfaces.

1. Install the dispenser at least 10" above countertop. (See Figure 5)

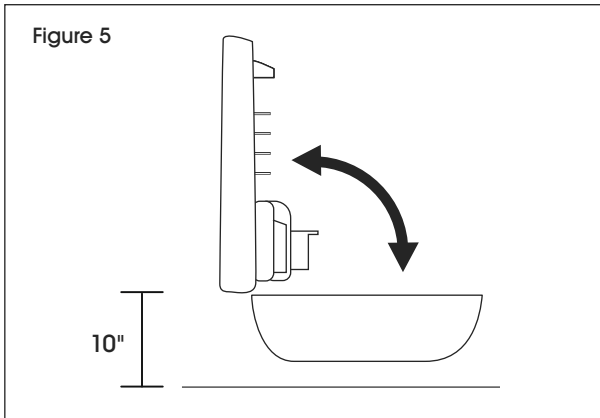

2. Use dispenser back plate as template. Pierce and drill four holes using using 1/4" drill bit. (See Figure 6)

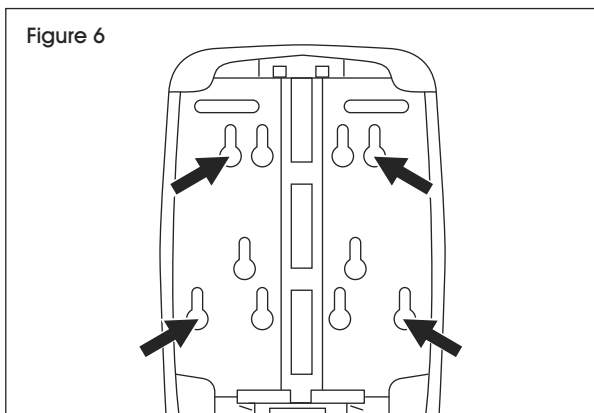

3. Install #10 x 1" anchors into the previously drilled holes. (See Figure 7)

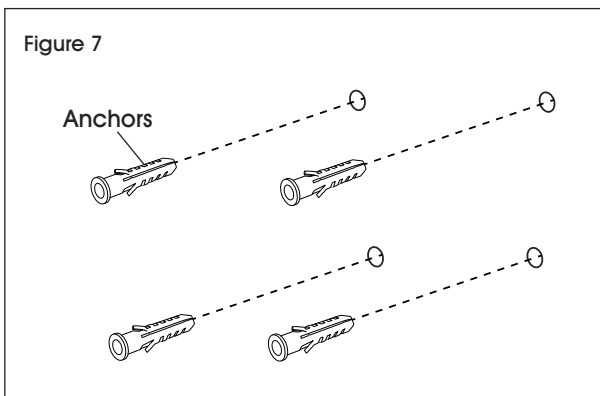

4. Insert Type A #10 x 1" screws into installation holes in back plate and through installation tape. Leave 1/2" between screw head and wall. (See Figure 8)

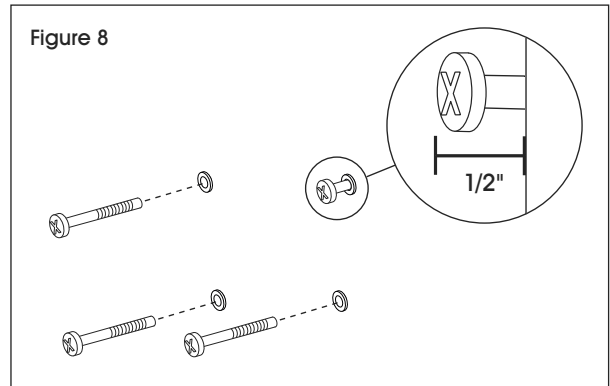

5. Place dispenser over screws on wall. Push dispenser down until screws slide into narrow top of holes. (See Figure 9)

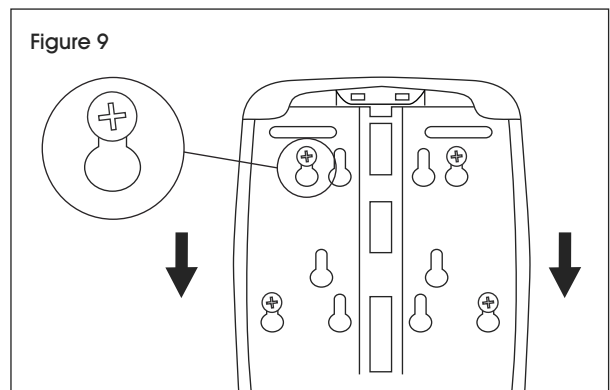

6. Tighten screws to secure. (See Figure 10)

 **NOTE:** Do not overtighten screws.

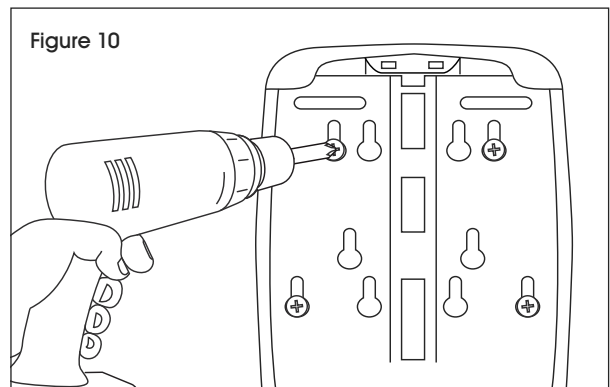

LOCK OPTIONS

STANDARD KEY

1. Insert standard key into key access hole underneath the dispenser. (See Figure 11)

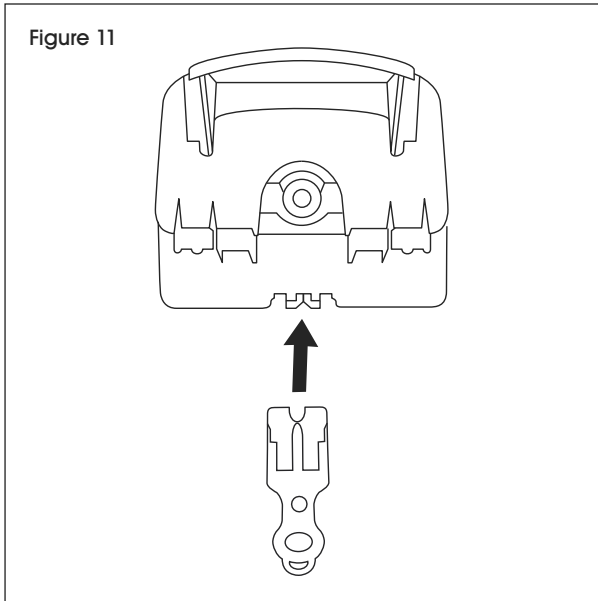

2. Push up until front cover opens. (See Figure 12)

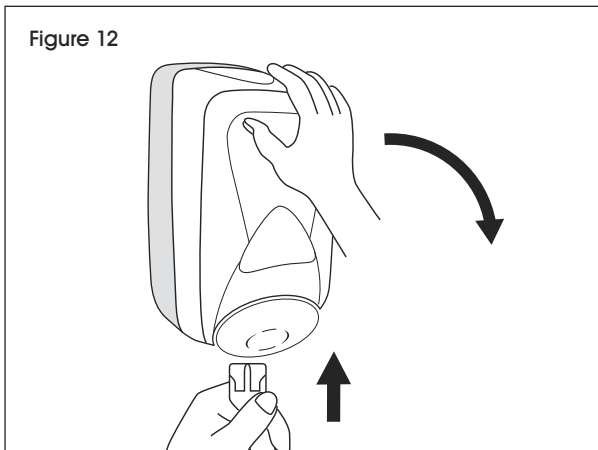

LOCK BYPASS



IMPORTANT! This option is permanently affixed once it has been inserted into the dispenser.

1. Snap insert into key access hole. Ensure it snaps into place. (See Figure 13)

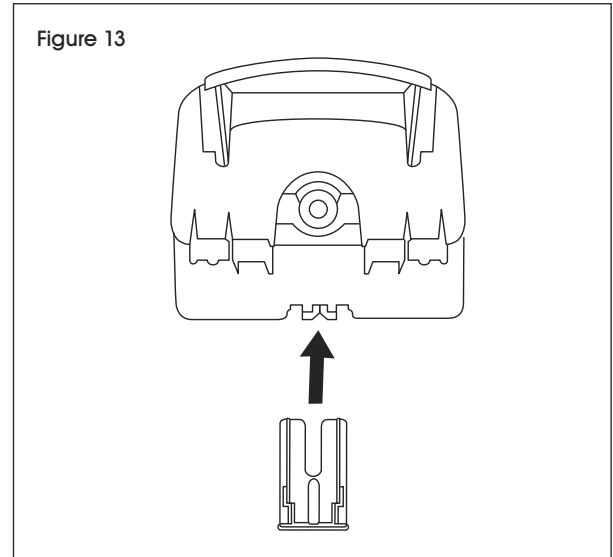

2. Push insert up until front cover opens. (See Figure 14)

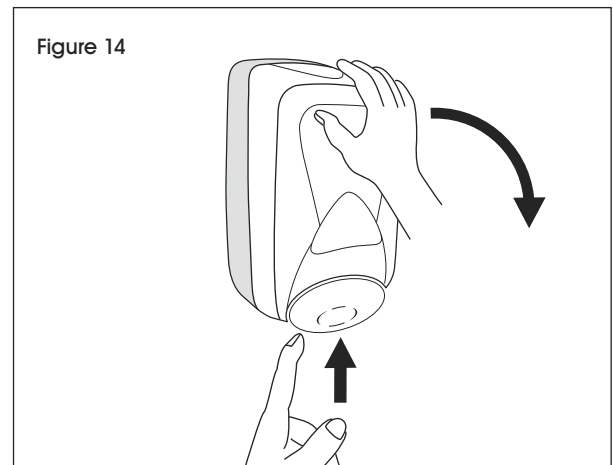

ULINE

1-800-295-5510
uline.com

ULINE H-2557

GOJO® DESPACHADOR MANUAL DE JABÓN EN ESPUMA

800-295-5510

uline.mx

HERRAMIENTAS NECESARIAS

Para instalación de tornillería opcional (no incluida):



Taladro Eléctrico



Broca de 1/4"

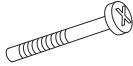

4 Tornillos Tipo A #10 x 1"



4 Taquetes #10 x 1"

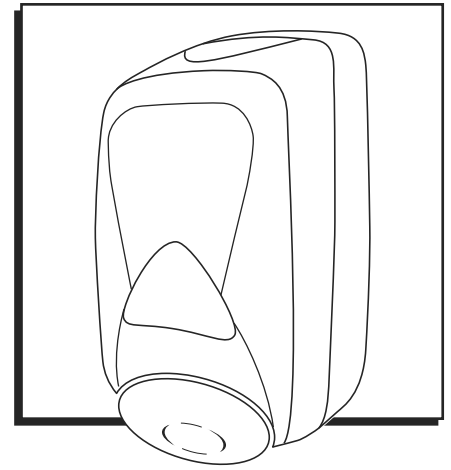

INSTALACIÓN

INSTALACIÓN CON CINTA ADHESIVA



NOTA: Utilice solo en superficies lisas y secas.

1. Limpie la superficie de instalación con un paño con alcohol (no incluido). Permita que la superficie se seque por 60 segundos.
2. Instale el despachador por lo menos 25.4 cm (10") por encima del mostrador. (Vea Diagrama 1)

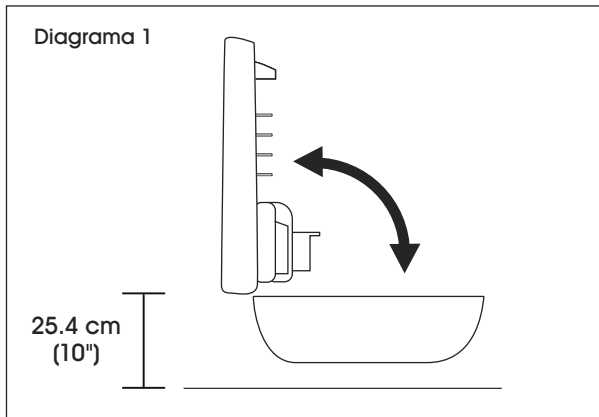

3. Retire el respaldo de papel de la cinta adhesiva y presione firmemente el despachador en su lugar. (Vea Diagrama 2)

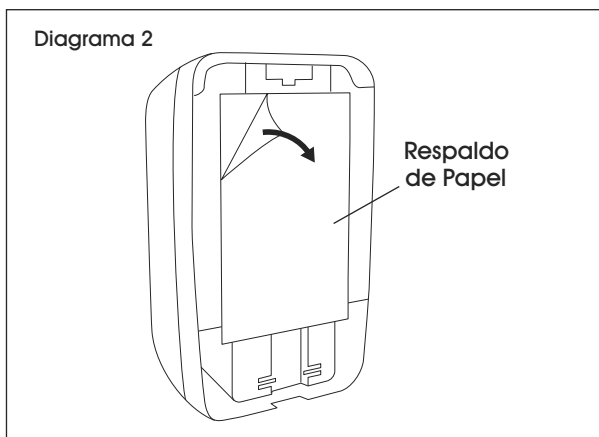

4. Abra el despachador insertando la llave en el orificio de acceso y empuje hacia arriba hasta que se abra la tapa frontal. (Vea Diagrama 3)

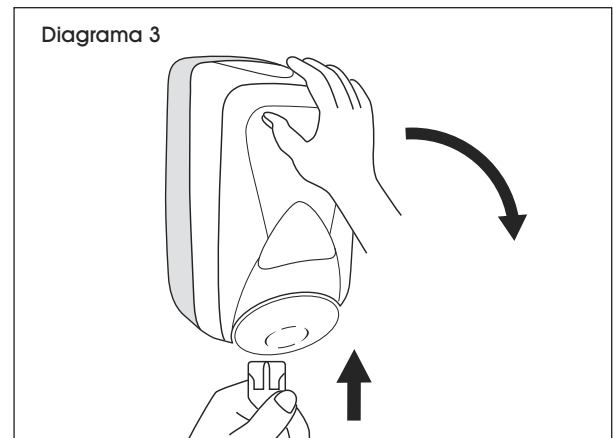

5. Presione la placa posterior firmemente durante 30 segundos. Para máxima adhesión, no coloque el jabón de repuesto hasta que pasen 24 horas. (Vea Diagrama 4)

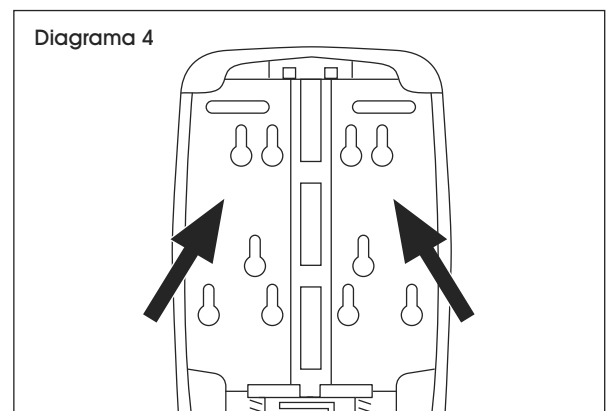

CONTINUACIÓN DE INSTALACIÓN

INSTALACIÓN CON TORNILLERÍA

 **NOTA:** Utilice en superficies ásperas o lisas.

1. Instale el despachador por lo menos 25.4 cm (10") por encima del mostrador. (Vea Diagrama 5)

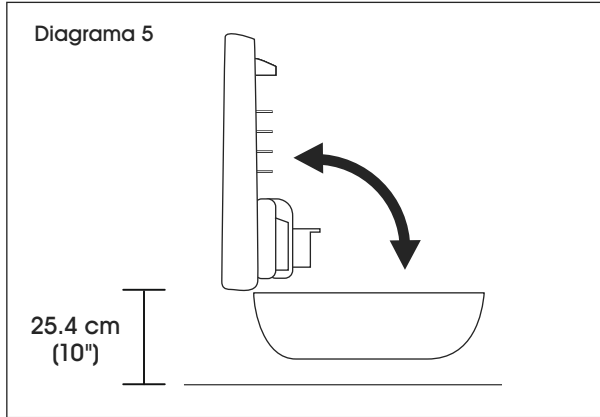

2. Utilice la placa posterior del despachador como plantilla. Perfore los cuatro orificios utilizando una broca de 1/4". (Vea Diagrama 6)

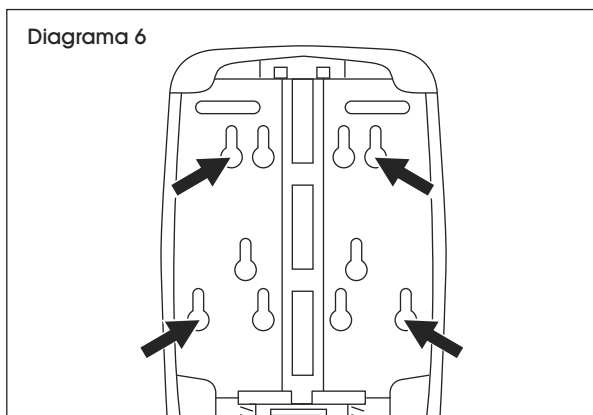

3. Instale los taquetes #10 x 1" en los orificios previamente perforados. (Vea Diagrama 7)

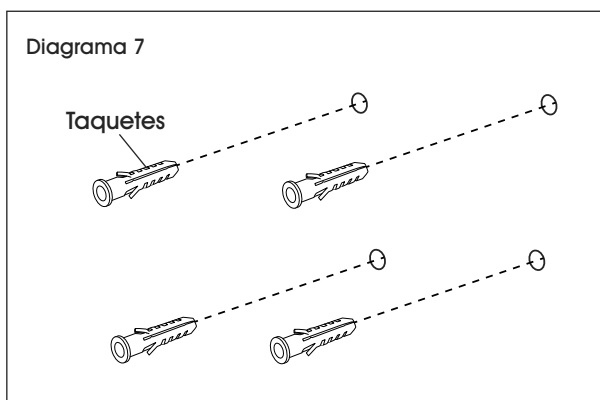

4. Inserte los tornillos tipo A #10 x 1" en los orificios de instalación de la placa posterior a través de la cinta adhesiva de instalación. Deje 1.3 cm (1/2") entre la cabeza del tornillo y la pared. (Vea Diagrama 8)

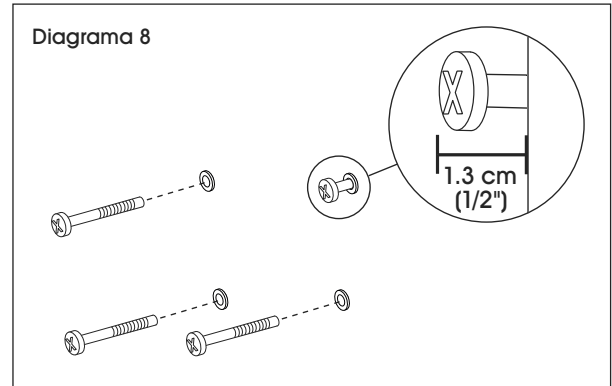

5. Coloque el despachador sobre los tornillos de la pared. Empuje el despachador hacia abajo hasta que los tornillos se deslicen en la parte superior angosta de los orificios. (Vea Diagrama 9)

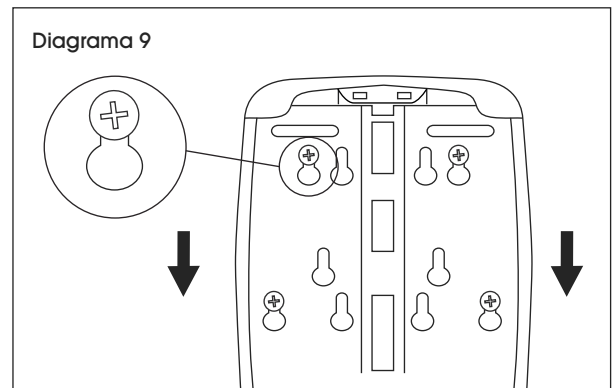

6. Apriete los tornillos para asegurarlo. (Vea Diagrama 10)

 **NOTA:** No apriete demasiado los tornillos.

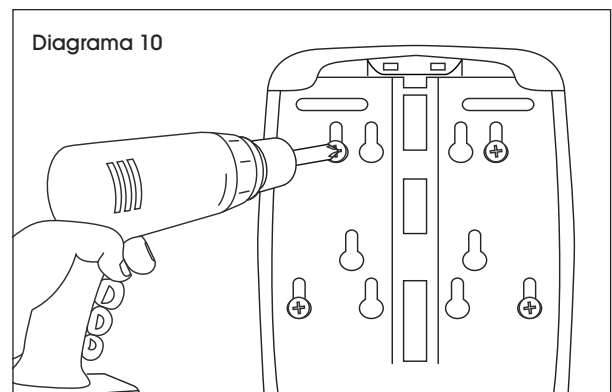

OPCIONES DE BLOQUEO

LLAVE ESTÁNDAR

1. Inserte la llave estándar en el orificio de acceso que se encuentra debajo del despachador. (Vea Diagrama 11)

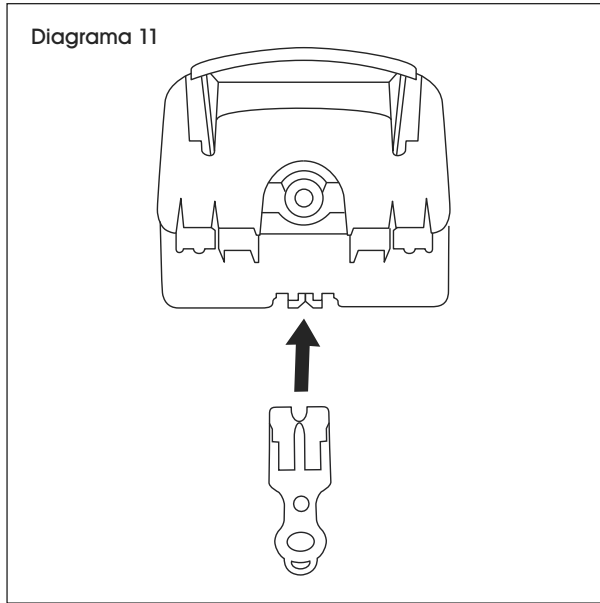

2. Empuje hacia arriba hasta que se abra la tapa frontal. (Vea Diagrama 12)

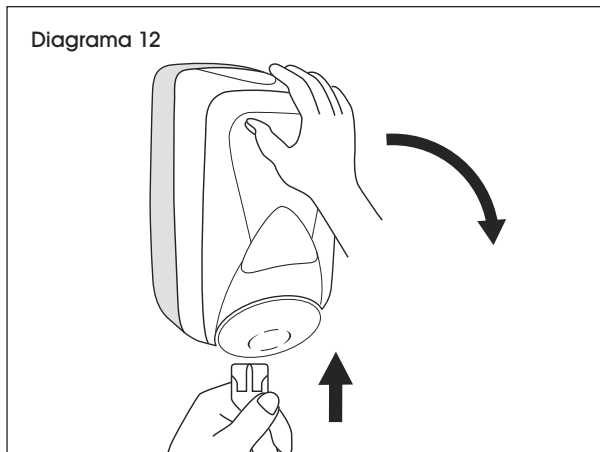

OPCIÓN SIN LLAVE



¡IMPORTANTE! Esta opción queda fija de forma permanente una vez que se ha insertado en el despachador.

1. Presione la pieza en el orificio de acceso hasta que encaje. Verifique que encaje correctamente en su posición (Vea Diagrama 13)

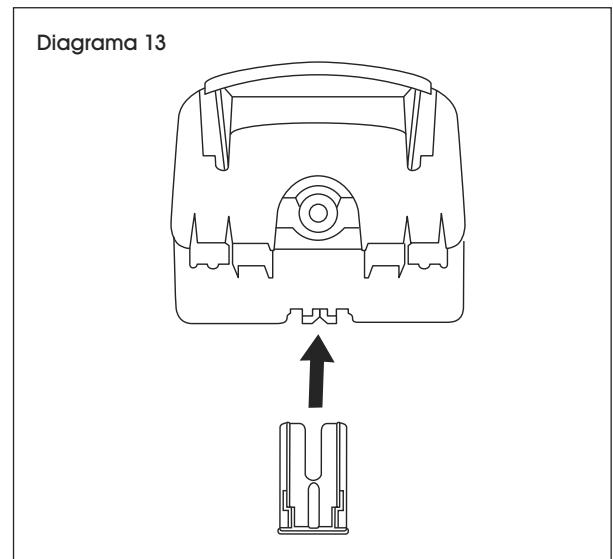

2. Empuje hacia arriba hasta que se abra la tapa frontal. (Vea Diagrama 14)

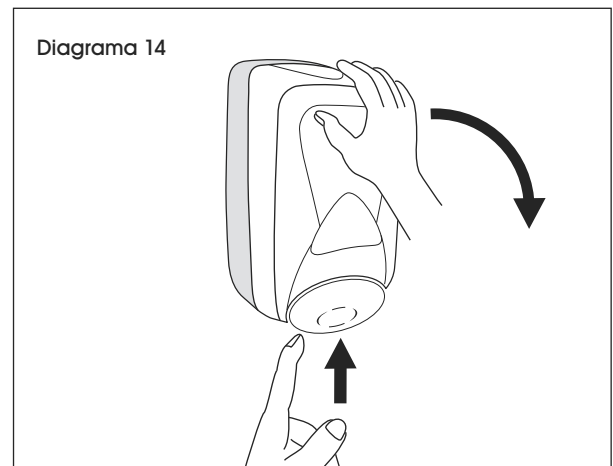

ULINE

800-295-5510
uline.mx

ULINE H-2557

GOJO^{MD} – DISTRIBUTEUR DE SAVON MOUSSANT AVEC BOUTON POUSSOIR

1 800 295-5510
uline.ca

OUTILS REQUIS

Pour installation en option avec matériel de fixation (non inclus) :



Perceuse électrique



Mèche de perceuse de 1/4 po

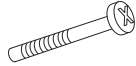

Vis de type A n° 10 x 1 po x 4



Ancre n° 10 x 1 po x 4

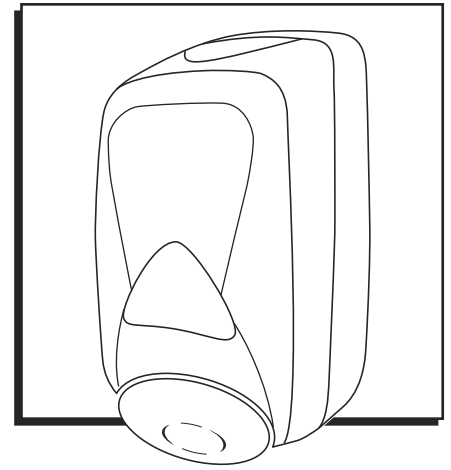

INSTALLATION

INSTALLATION AVEC RUBAN ADHÉSIF



REMARQUE : À utiliser uniquement sur des surfaces sèches et lisses.

1. Nettoyez la surface d'installation avec un tampon imbibé d'alcool (non inclus). Laissez sécher la surface pendant 60 secondes.
2. Installez le distributeur à une hauteur d'au moins 25,4 cm (10 po) au-dessus du comptoir. (Voir Figure 1)

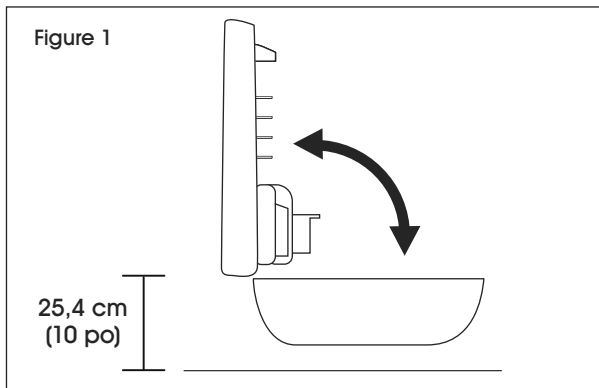

3. Retirez la doublure de papier du ruban adhésif, puis pressez fermement le distributeur sur la surface. (Voir Figure 2)

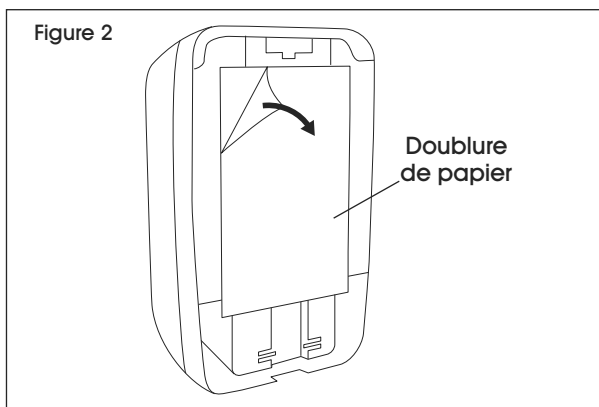

4. Insérez la clé dans le trou d'accès pour ouvrir le distributeur, puis poussez vers le haut jusqu'à ce que le couvercle s'ouvre. (Voir Figure 3)

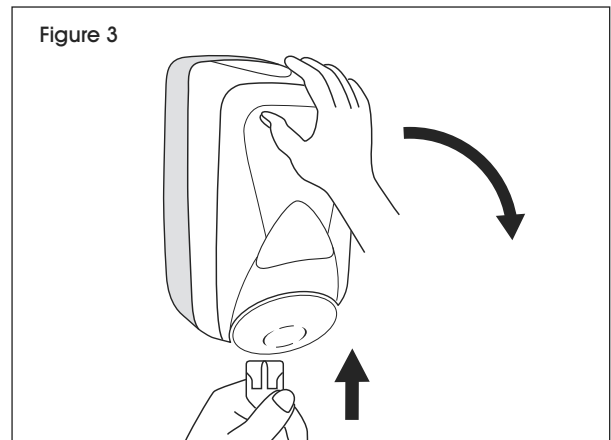

5. Pressez fermement la plaque arrière pendant 30 secondes. Pour une adhésion maximale, attendez 24 heures avant d'insérer une recharge. (Voir Figure 4)

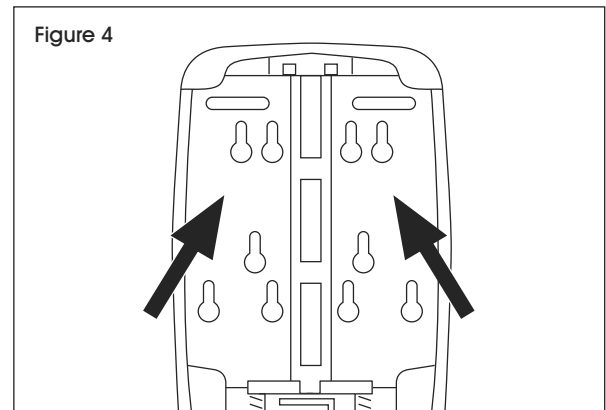

INSTALLATION AVEC MATÉRIEL DE FIXATION

 **REMARQUE :** À utiliser sur des surfaces rugueuses ou lisses.

1. Installez le distributeur à une hauteur d'au moins 25,4 cm (10 po) au-dessus du comptoir. (Voir Figure 5)

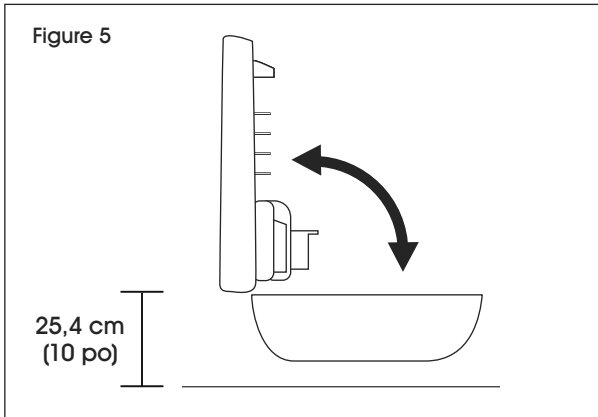

2. Utilisez la plaque arrière du distributeur comme modèle. Percez quatre trous en utilisant une mèche de perceuse de 1/4 po. (Voir Figure 6)

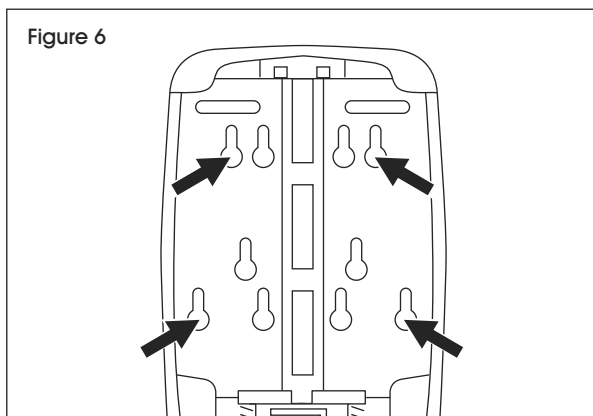

3. Installez des ancrages n° 10 x 1 po dans les trous prépercés. (Voir Figure 7)

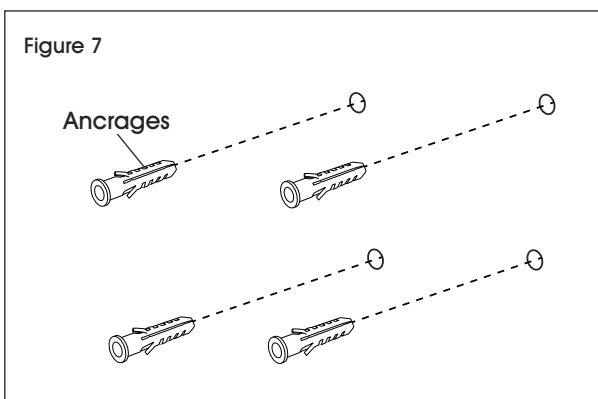

4. Insérez des vis de type A n° 10 x 1 po dans les trous d'installation à l'arrière de la plaque, en passant à travers le ruban adhésif d'installation. Laissez un espace de 1,3 cm (1/2 po) entre la tête de la vis et le mur. (Voir Figure 8)

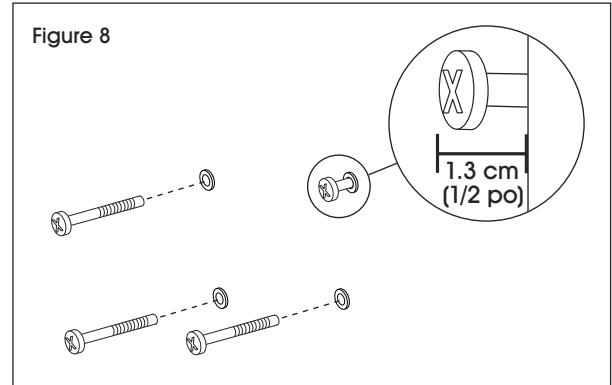

5. Placez le distributeur au mur sur les vis. Poussez le distributeur vers le bas jusqu'à ce que les vis glissent dans la partie supérieure étroite des trous. (Voir Figure 9)

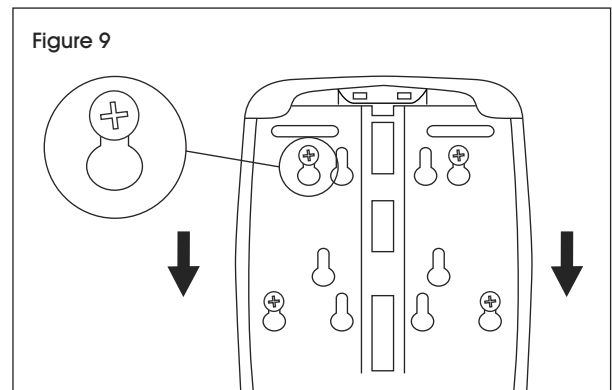

6. Serrez les vis pour fixer le distributeur. (Voir Figure 10)

 **REMARQUE :** Ne serrez pas trop les vis.

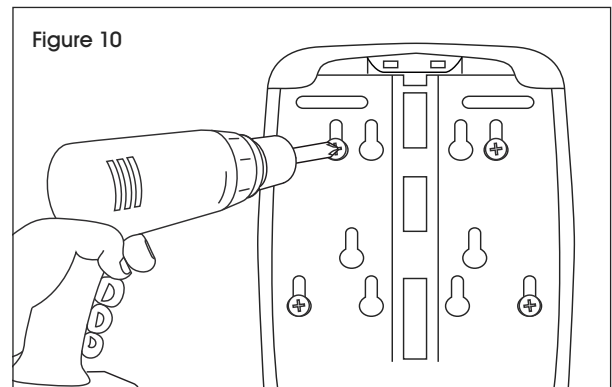

OPTIONS DE VERROUILLAGE

CLÉ STANDARD

1. Insérez la clé standard dans le trou d'accès pour clé sous le distributeur. (Voir Figure 11)

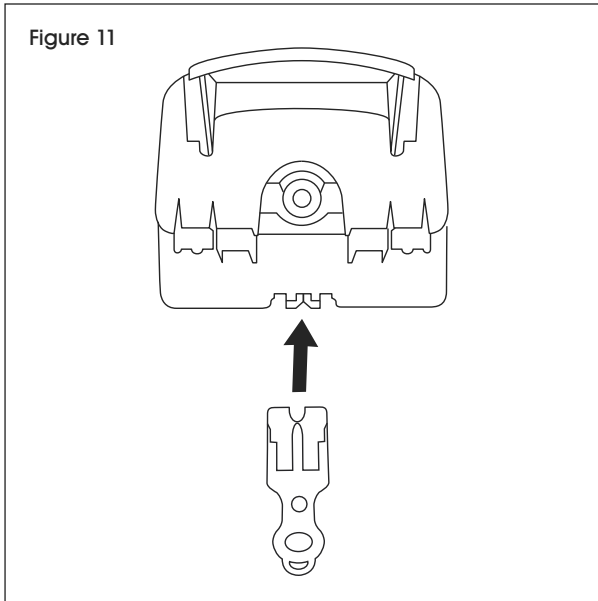

2. Poussez vers le haut jusqu'à ce que le couvercle s'ouvre. (Voir Figure 12)

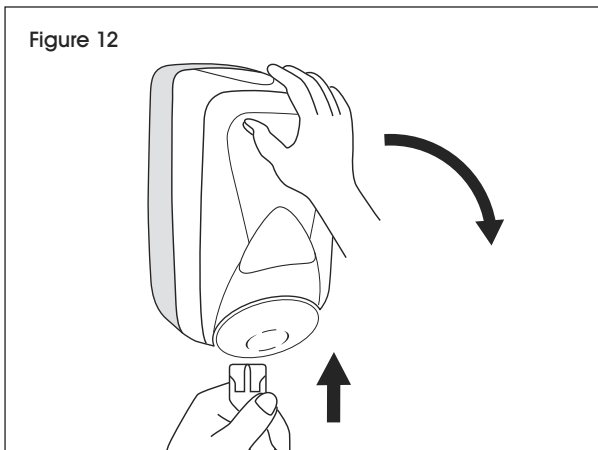

OPTION SANS CLÉ



IMPORTANT! Cette option est permanente une fois la pièce insérée dans le distributeur.

1. Enclenchez la pièce dans le trou d'accès. Assurez-vous qu'elle est bien enclenchée. (Voir Figure 13)

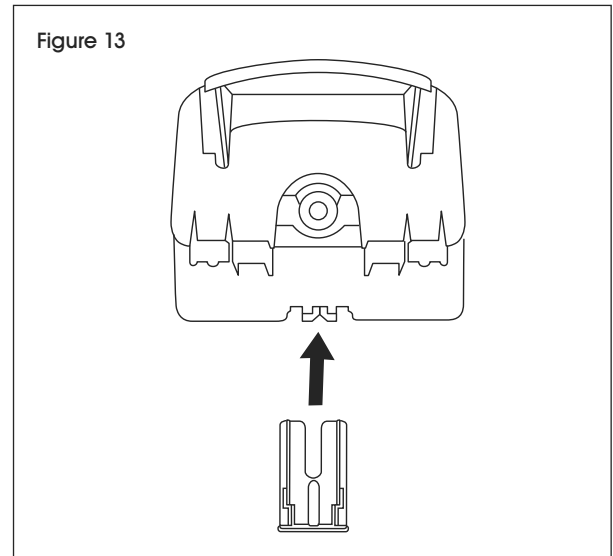

2. Poussez vers le haut jusqu'à ce que le couvercle s'ouvre. (Voir Figure 14)

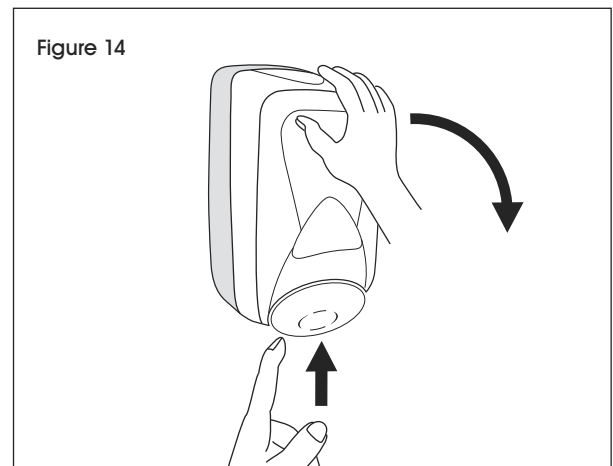

ULINE

1 800 295-5510
uline.ca